

Garrard

AUTO TURNTABLE TYPE AT6



Introduction

The Garrard AT6 has been designed as a record changer with completely automatic record selection. It has, as an important feature, a specially designed transcription pickup arm for high quality reproduction on both Automatic and Manual play.

As owner of this model, you have a unit of compact modern design where special attention has been given to detail ensuring the best possible performance.

This booklet has been prepared to help you enjoy and maintain the high performance of which this unit is capable.

Should you require any further information or advice not covered by this booklet, please ask your nearest Garrard agent or write to our Technical Service Department, Newcastle Street, Swindon, Wilts. (Swindon 5381), or for spare parts and service returns, to our Service and Spares Department, 50-54 Radnor Street, Swindon, Wilts. (Swindon 22606). In U.S.A. Garrard Sales Corporation, 80 Shore Road, Port Washington, New York. (P 07, 7700). In Canada, Charles W. Pointon Limited, 66 Racine Road, Rexdale, Ontario (CH 7-8777).

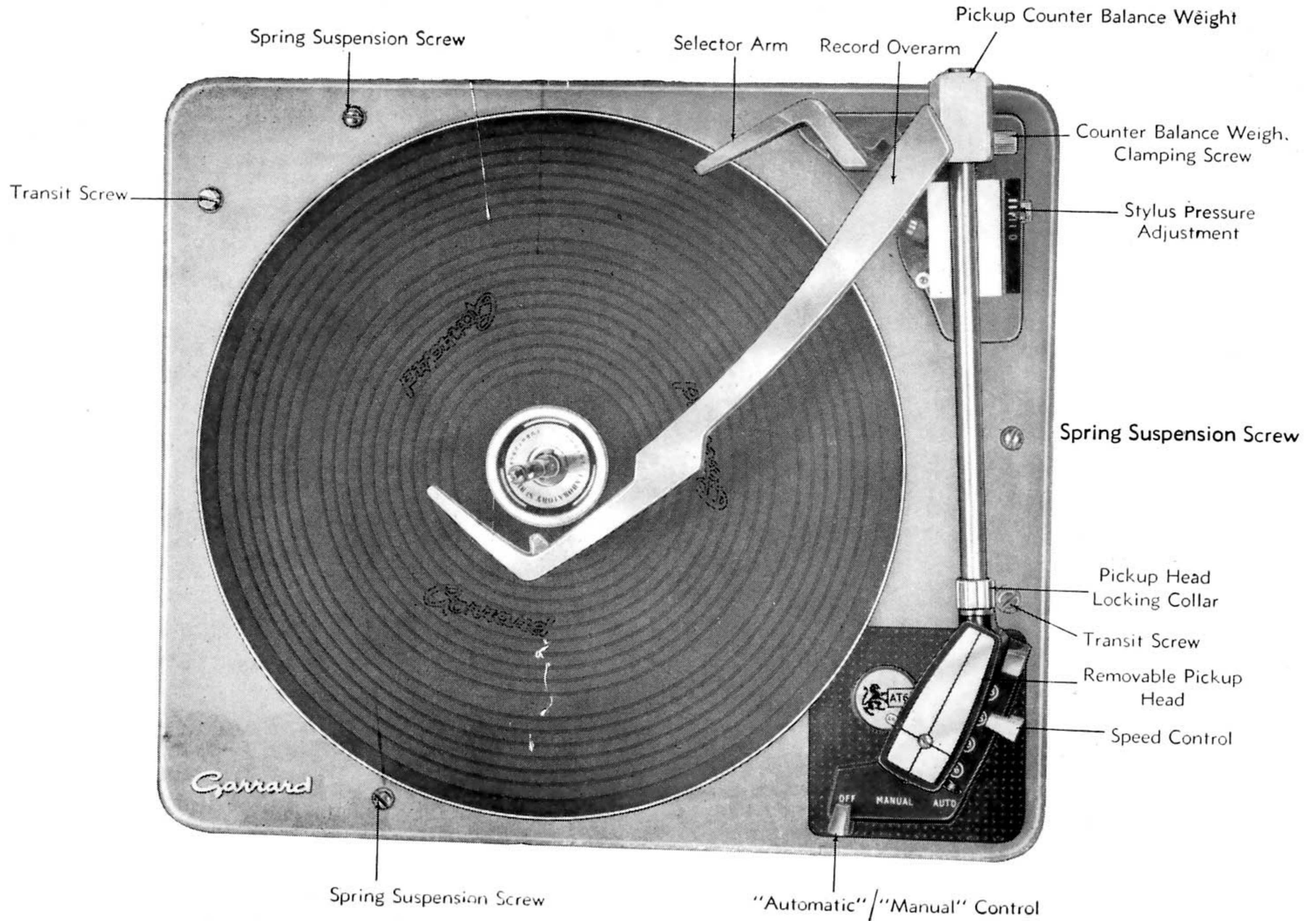

Diagram I

Operation

The Garrard AT6 will play automatically 7", 10" or 12" diameter records, which can be mixed in any order providing they are of the same speed. No setting for record size is required, the selection being completely automatic.

7" 45 r.p.m. records with large centre holes may be played automatically using the large record spindle type L.R.S.6, available as an optional extra.

Records may also be played manually as on a single record player, a manual spindle being provided for this purpose.

To operate for automatic play

1. See that correct stylus is in position for type of record to be played and raise pickup arm to release from catch.
2. Move speed change control to required speed.
3. Place records horizontally on record spindle and move overarm in over centre of records.
4. Switch on by moving the automatic control to "Auto".
The unit will return the pickup arm to its rest and switch off after the last record has been played.

To unload

1. When the unit has switched off automatically, lift overarm and move it to right hand side.
2. Lift records off spindle. If replaying the same records lift them clear of the spindle before replacing.

To operate for manual play

1. See that correct stylus is in position for type of record to be played and move speed change control to required speed.
2. Lift out the centre spindle and replace it with the short manual spindle.
3. Load record on turntable and replace the overarm in operating position.
4. Switch on by moving the Automatic Control to "Manual" then place the pickup on the record.
5. When the record has been played the pickup arm will return to its rest and switch off.

To replace the automatic record spindle rotate it until location is felt, then press firmly downwards to secure it in the turntable clip.

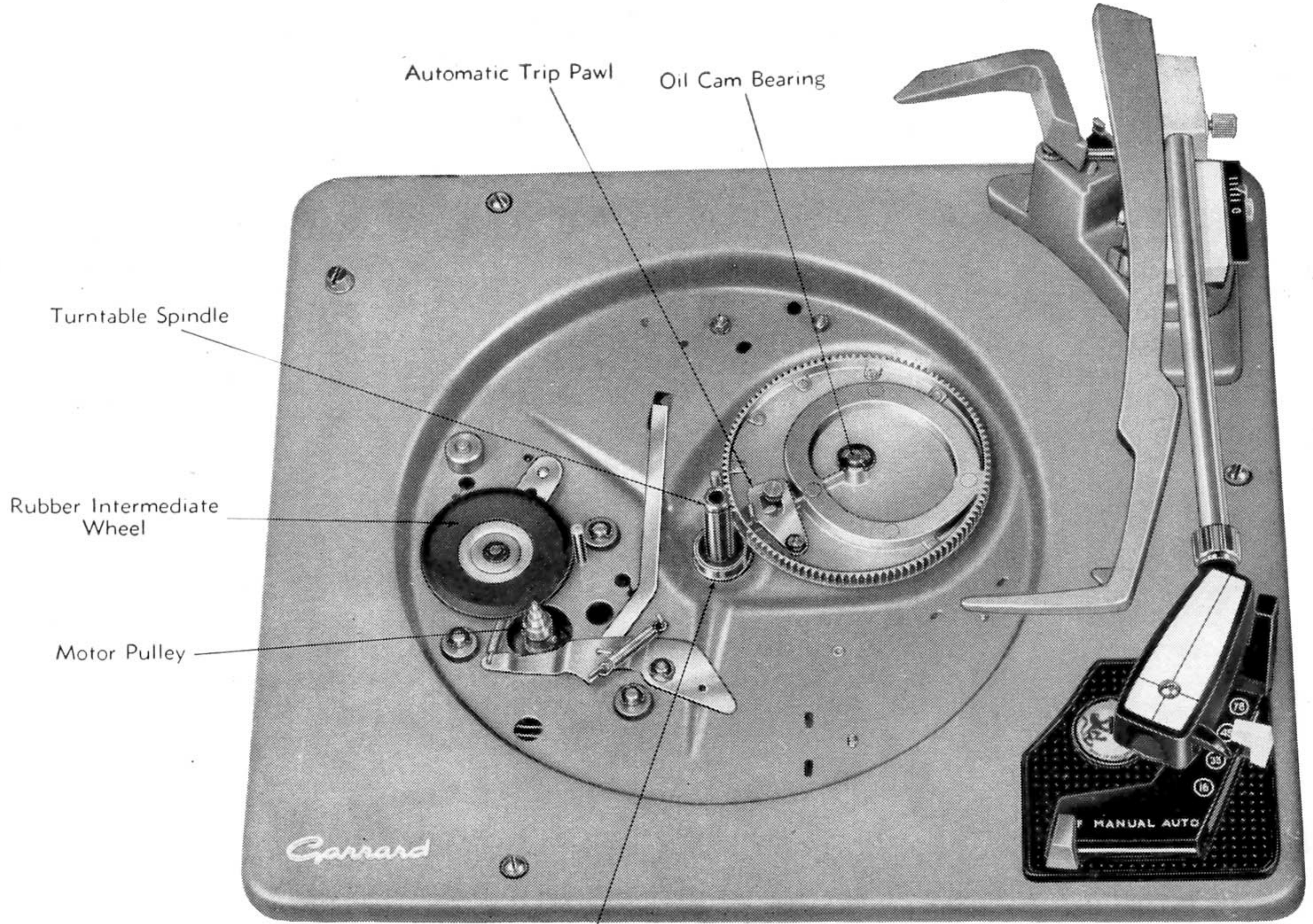

Diagram 2

Ball Race (lightly oil)

Lightly oil all pivot points

Reject

A record being played may be rejected by moving the Automatic Control to "Auto".

Stop

If you require to stop the unit while playing a record, move the Automatic Control to "Off": the motor will then stop with the pickup remaining on the record. Restart by moving the Automatic Control to "Manual" and the same record will continue playing.

Note

In order to prevent damage to the stylus the Automatic Control should not be switched to the "Auto" position until records have been loaded on the Record Spindle. To obtain the best results from your records see that they are stored and cleaned as recommended by the record manufacturers. Do not leave records on the changer when not in use.

Replace stylus when worn and keep it free from accumulated dust.

Maintenance

The motor and intermediate wheel bearings are of the oil retaining type and rarely need lubricating. When the need for oil is apparent, hold the intermediate wheel away from contact with the motor pulley and lubricate the top motor bearing with a fine grade of machine oil; that used for sewing machines is suitable. Also lubricate the intermediate wheel bearing, the bearing on the turntable spindle and very occasionally, the bottom motor bearing. Remove all traces of surplus oil before running and make sure that the motor pulley, running surface of the intermediate wheel and inside of turntable rim are clean and free from oil. Oiling points are shown on diagrams 2 and 4.

To remove the turntable, to gain access to the oiling points, remove the name plate from the centre of the turntable by levering it upward with a screwdriver or penknife in one of the slots. Now remove the turntable retaining clip and lift off the turntable with equal pressure on diametrically opposite sides.

To replace the turntable, check that the gap in the teeth of the main gear is adjacent to the turntable spindle and that the automatic trip pawl (see diagram 2) is pushed away from the turntable spindle. The turntable will now slide on easily. Assemble the retaining clip in the groove in the turntable spindle, making sure that the wedge part on the clip fits in the slot in the groove.

Installation

Dimensions

The Garrard AT6 requires cabinet space $15\frac{3}{8}$ " long x $13\frac{1}{8}$ " wide with clearance for the pickup arm counterbalance weight of 3" radius for cartridges of less than 18 grammes dead weight, and $3\frac{1}{2}$ " radius for cartridges in excess of 18 grammes dead weight, the radius being measured from the pickup arm pivot. It requires $4\frac{7}{8}$ " above and $2\frac{7}{8}$ " below top of motor board. Recommended motor board thickness is $\frac{5}{16}$ " to $\frac{1}{2}$ "; should a thicker board be used it may be necessary to recess the transit screw holes from the underside to clear the clips on the ends of the transit screws.

Fitting

The motor board should be drilled and cut out to the template supplied. Do not moisten the template as it may distort, but fix it with self-adhesive tape.

Having removed the unit from the carton remove all cardboard packing, string, and elastic bands. The record spindles will be found in a separate packet on which are instructions for fitting them (see "Manual play" paragraph 5, page 3). The counterbalance weight for the pickup arm is packed in the cardboard liner; unpack it and slide it on to the rear of the pickup arm with its clamping screw forward (see diagram 1). Instructions for stylus pressure adjustment are on page ten.

Connect a power supply to the motor lead (or the connecting block if a dual voltage range unit). The motor should be earthed by connecting a lead, from a good earthing point to the earthing tag located on the motor.

Connect the audio leads from the amplifier to the pickup circuit muting switch as shown on diagram 3. If the unit is connected to an amplifier whose wiring is not isolated from the power supply, isolating components, either condensers or transformers should be incorporated in the pickup circuit, otherwise the pickup circuit can become live. If in doubt consult your dealer.

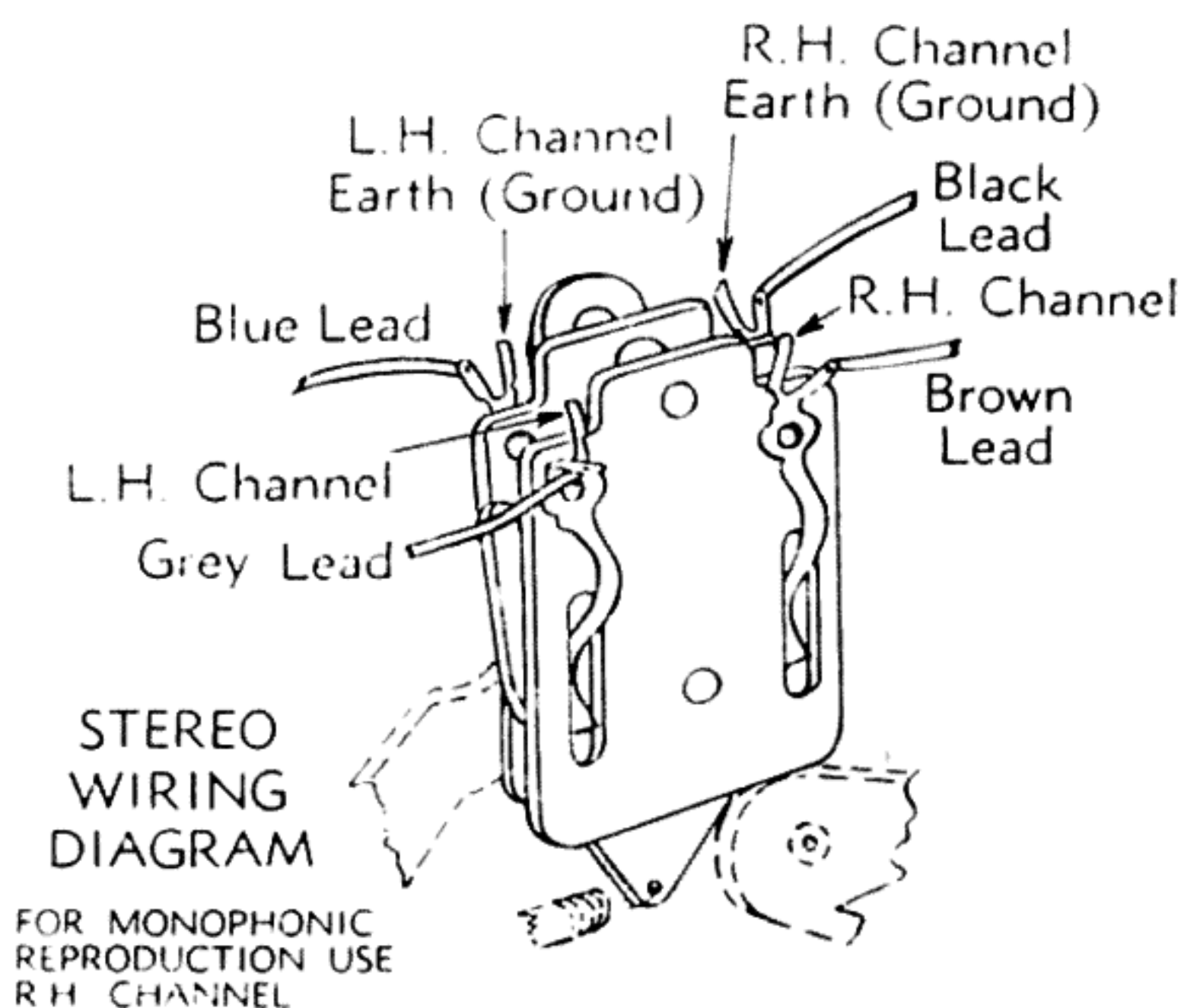

Diagram 3

The pickup leads from the pickup head through to the muting switch are colour coded thus:—

- Grey lead — Left Hand Channel
- Blue lead — Earthy Left Hand Channel
- Black lead — Earthy Right Hand Channel
- Brown lead — Right Hand Channel

Check that the transit screws looking from the top of the unit are screwed right down, see diagram 1. Then with the transit screw clips vertical, assemble the unit on to the motor board. When the unit is in place turn the clips horizontally so that the unit cannot be lifted off the board.

Turn the three spring suspension screws (see diagram 1) anti-clockwise to raise the unit so that it is freely spring mounted. Level the unit by turning one or more of the screws clockwise to lower the unit at that point or anti-clockwise to raise it. The level should be gauged with a spirit level placed on a record on the turntable.

Should you wish to transport your unit, turn the transit screws anti-clockwise until the unit is firmly clamped. Screw them down before using the unit again.

Voltage and Frequency

The Garrard AT6 is made as a low voltage range model suitable for 100/130 volts A.C. or as a dual voltage range model suitable for either 100/130 volts or 200/250 volts A.C.

These units are suitable for various frequencies of power supply depending on the motor pulley supplied. The motor pulleys are colour finished for easy identification: Nickel for 50 and Brass for 60 cycle power supply.

Service Adjustments

These notes are included to assist in making any minor adjustments that may become necessary. When making an adjustment protect the pickup when possible by fitting its protecting clip, or if a turnover pickup having a safety mid position, turn to this position to protect the styli from possible damage.

Speed

The Garrard AT6 is designed to give the required turntable speed within close tolerances. Should, however, the turntable run excessively fast or slow, the motor pulley may not be correct for the frequency of the power supply. The pulley is colour finished for identification: Nickel for 50 and Brass for 60 cycles. To gain access to the motor pulley, remove the turntable as described on page five under 'Maintenance'.

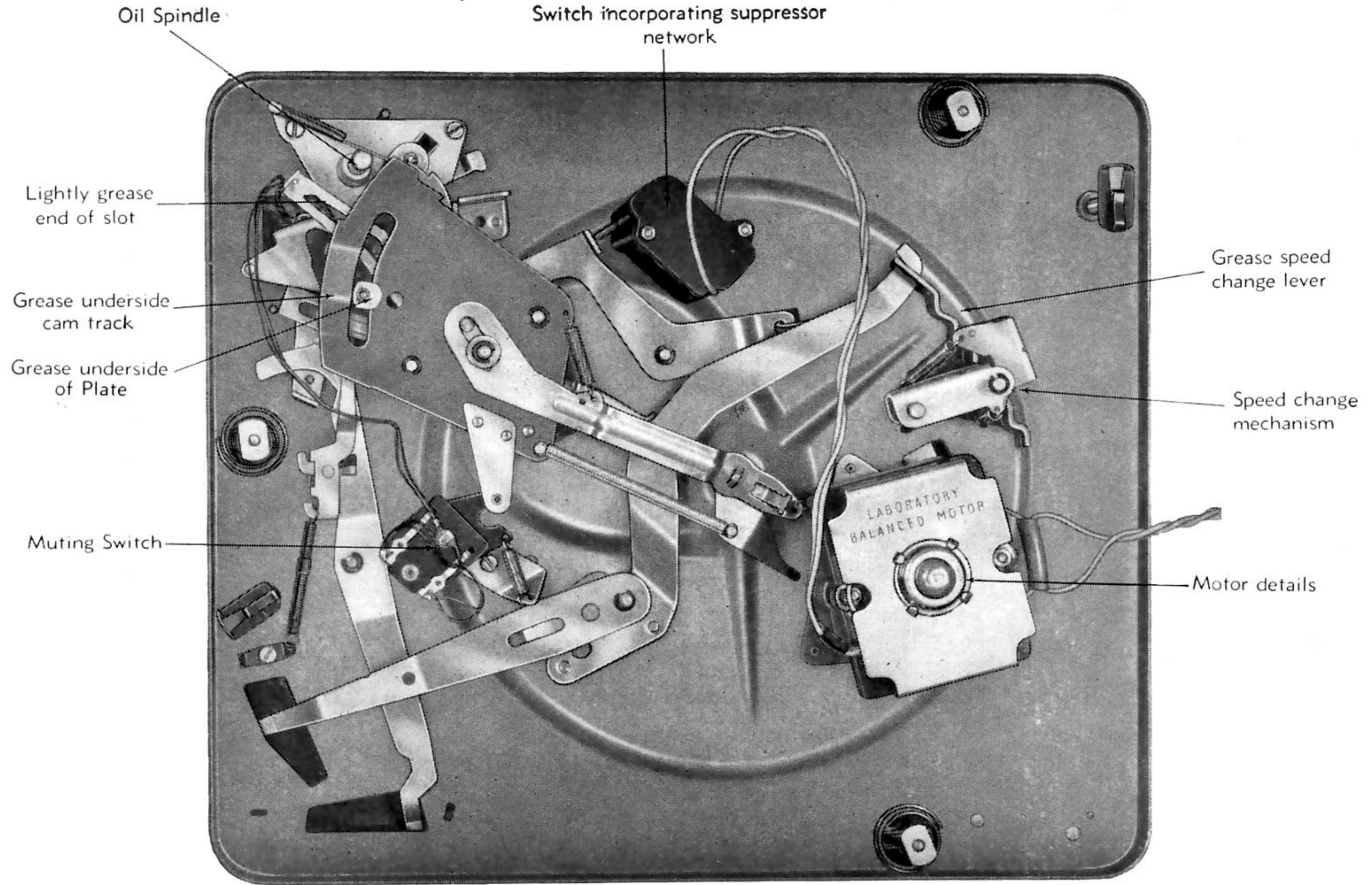

Lightly oil all pivot points

Diagram 4

Should the speed vary during playing, examine the motor pulley, rubber intermediate wheel and inside of turntable rim for traces of oil. Wipe them thoroughly with a clean cloth.

Check that the two small screws holding the motor pulley on the motor shaft are tight. See that the intermediate wheel runs in the centre of the appropriate pulley step and does not rub on the side of the adjacent step. If necessary, loosen the screws holding the pulley to the shaft and adjust the height of the motor pulley. If this adjustment brings the height of the top of the pulley (i.e. top of the 16 r.p.m. step) above the height of the intermediate wheel stop pin (see diagram 2), the height of the intermediate wheel should be adjusted by moving the spring blade positioned in the speed change mechanism underneath the unit (see diagram 4). If in doubt consult your dealer.

Motor

If the motor fails to start when the unit is switched on, check the power supply to see that current is reaching the motor. With the current switched off check the switch, which is fitted with a suppressor network and shown on diagram 4. See that the contacts are clean and make a good connection when closed.

Make sure that the motor is suitable for the voltage of the power supply. The motor details will be found stamped around the flange of the bottom bearing cover (see diagram 4).

If you have a dual voltage range model, check that the links inside the voltage changeover block are correctly set as shown on the voltage changeover block cover. The voltage changeover block fitted to the dual voltage range model is on a bracket alongside the motor.

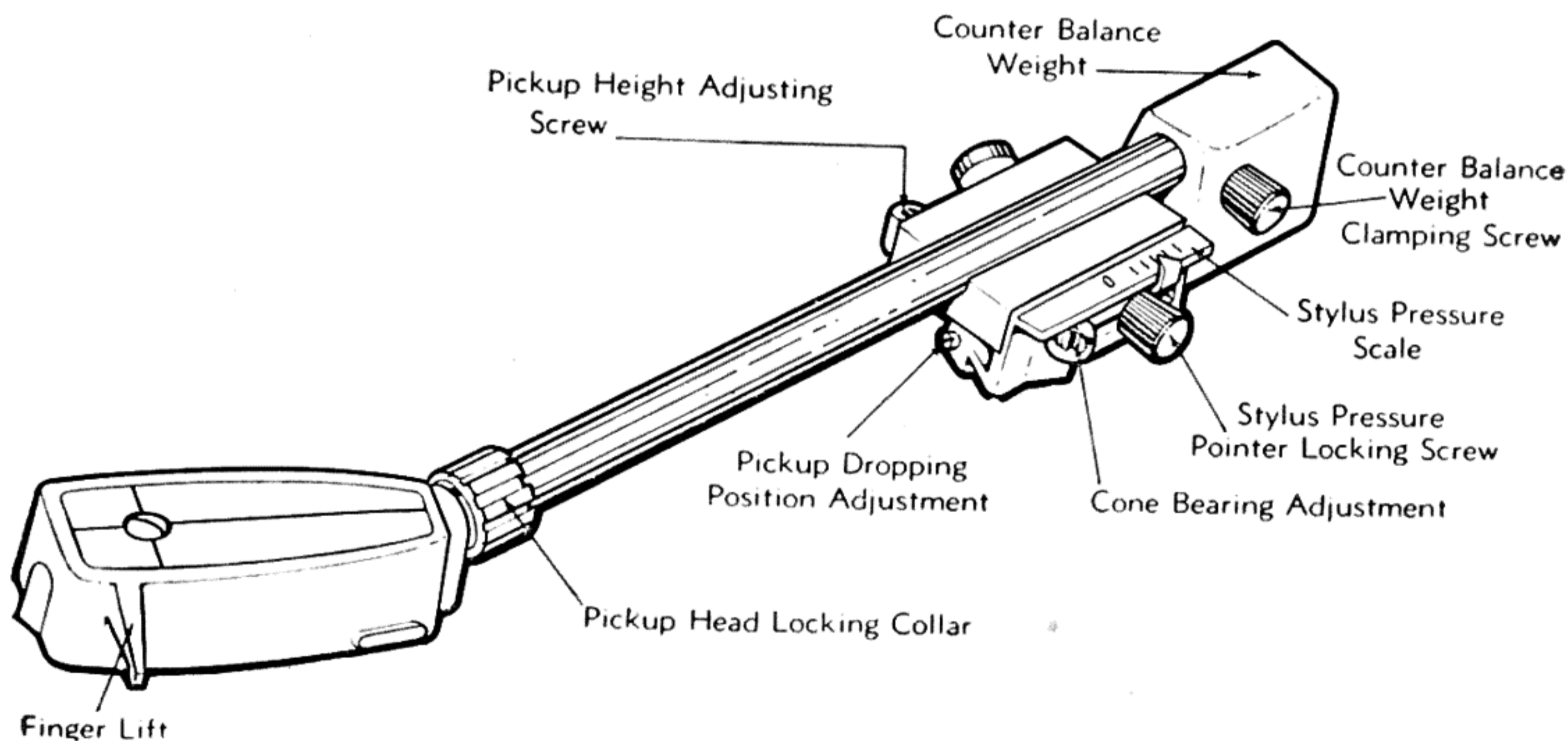

Diagram 5

Pickup Dropping Position

The pickup dropping position is factory set for optimum accuracy; should, however, any minor adjustment be required the small screw on the front end of the pickup arm pivot bracket, just below the pickup arm tube, should be turned (see diagram 5). Turn it clockwise to move dropping position inwards and anti-clockwise to move dropping position outwards.

Pickup Height

The height that the pickup lifts off the record when the unit is playing automatically can be adjusted by turning the top screw at the left hand side of the pickup arm pivot bracket (see diagram 5). The height should be set so that the stylus point is $\frac{7}{8}$ " above the turntable mat as the pickup is returned to its rest.

Pickup Stylus Pressure

To set the stylus pressure unscrew the knurled screw holding the pointer on the stylus pressure scale. Slide this pointer forward to the zero mark on the scale; do not tighten the screw. Now loosen the screw holding the counterbalance weight on the rear of the pickup arm. With the pickup arm off its rest slide the weight along the arm until the point of balance with the pickup head is obtained. Tighten the counterbalance weight fixing screw. To set the required stylus pressure slide the pointer along the scale which is graduated in 1 gram divisions then tighten the pointer locking screw. The stylus pressure should be set to the amount recommended by the stylus cartridge manufacturers.

Pickup Tracking

Should there be a tendency for the pickup to track incorrectly check that the correct stylus is being used for the type of record being played. See that the leads from the rear of the pickup arm are free and clear of the sides of the slot where they pass through the unit plate. Check that the stylus pressure is that recommended by the cartridge manufacturer. Also see that the unit is level by placing a spirit level on a record on the turntable. Check in two directions, side to side and back to front, turning the spring suspension screws to adjust its level as described on page 7.

Pickup Muting Switch

The pickup is muted on both channels by means of a switch which short circuits the pickup connections during the time the changing mechanism is in action.

To remove and replace the pickup head

To remove the pickup head unscrew its locking collar (see diagram 5) and gently pull it from the arm. To replace the head, locate the pin on the pickup head in the slot in the pickup arm and slide head in. Then bring the locking collar forward and screw it up until tight.

Should you require any additional information or spare parts please quote the schedule number printed on the specification label under the turntable mat and also the series number and code number supplied with your changer.

SPARE PARTS LIST

Name of Part	Ref. No.
Automatic Record Spindle	58874
Manual Record Spindle	58954
Large Record Spindle (type LRS6) ...	59010
Turntable Assembly	58856
Turntable Mat	57422
Pickup Arm (complete less head)	58586
Pickup Head Assembly M6 (less cartridge)	58891
Pickup Arm Counterbalance Weight Assembly	59080
Motor Pulley for 50 cycle power supply ...	58646
Motor Pulley for 60 cycle power supply ...	58650
Intermediate Rubber Drive Wheel	58220
Rotor Spindle with Rotor	54413
Switch Cover	58731
For dual voltage range models	
Cover for Changeover Block	58179
Fixing nut for above	41012

Replacement Styli, both Sapphire and Diamond, available for all Garrard Pickups.

Genuine Garrard Styli give best results.

Scans by www.vinylengine.com



THE GARRARD ENGINEERING AND MANUFACTURING CO. LTD.
SWINDON - WILTSHIRE - ENGLAND