

Technics SL-10

Quartz-Phase-Locked
Control Direct-Drive
Turntable with Linear Tracking
Tonearm



QUARTZ



with the upper and lower halves of the cabinet closed during record play. And the tonearm is designed so that the system can be stood vertically without any sacrifice in tracking accuracy. The SL-10 marks as great a step forward in convenience as did the development of cassette tapes versus the open-reel format. Yet there is absolutely no loss in reproduction quality. On the contrary, numerous factors in the SL-10's design will significantly enhance the sound from records.

A Compact Quartz DD Unit, with the Dimensions of a Record Jacket.

The aluminum die-cast cabinet opens up into upper and lower halves. The upper half contains the linear tracking tonearm, its drive control system, and a micro-computer electronic control block. The lower half contains Technics' integral rotor/platter DD motor, and its driving and quartz-phase-locked control circuit. Never before has there been this much advanced electronics and precision mechanical engineering technology in such a compact turntable system.

Put on a Record, Press the Start Button, and Leave the Rest to the Turntable.

To use the SL-10, place a record on the turntable, close the lid to seal it, and press a button to start. After that, the turntable takes over, using a precision optoelectronic detection system to determine stylus contact points, and the beginning and end of play. Thanks to the unique die-cast configuration, compact dimensions, and dynamically balanced linear tracking arm, this turntable can be used in the usual flat position, or can be stood upright, during use.

Optoelectronic Sensor for Precision Servo Control of the Linear Tracking Tonearm. Unique Dynamically Balanced Arm Design Allows both Horizontal and Vertical Operation with Excellent Tracking Ability.

An advanced coreless DC motor drives the arm and an optical sensor located near the stylus tip governs automatic operation. The optoelectronic system is based on deflection angle detection and is far more accurate than those that operate near the suspension. Thanks to this system, cartridge/groove geometry is always maintained near the ideal relationship. There is virtually no lateral tracking error ($\pm 0.1^\circ$), and therefore no

Marking the 10th anniversary of the direct-drive turntable

It has been 10 years since Technics introduced the world's first direct-drive turntable, the SP-10. When it was introduced this turntable had less wow and flutter and better speed accuracy than the cutting lathes used to make records. And because the drive system did not use rubber parts like belts and idler wheels, it insured that its excellent specifications would be retained for a long time.

Six years after the introduction of the SP-10, Technics brought out an improved version, with higher torque and quartz control. Today, more than 1500 of these SP-10MKII's are used by broadcasters in 27 countries around the world. In the past two years, Technics has added quartz synthesizer control to various models, permitting the precision of quartz to be retained in speeds above and below the standard 33-1/3, 45 and 78 rpm.

More significant to the consumer, Technics has also developed direct-drive turntables which have a very high degree of precision, yet cost much less than the professional grade models. It is possible to get numerous Technics direct-drive turntables in the popular price range, yet with specifications that were obtainable only in very expensive equipment a few years ago. With the SL-10, Technics continues to lead the industry in turntable innovation. This new turntable represents as radical a departure from conventional design as did the SP-10 ten years ago.

It has the same width and depth dimensions as an LP record jacket, yet within the compact package are an amazingly precise drive system, a gimbal suspended linear-tracking tonearm, a high-grade moving coil cartridge, plus extensive control systems which permit even a complete hi-fi novice to use the SL-10 without any problem. Nearly every operation is automated,

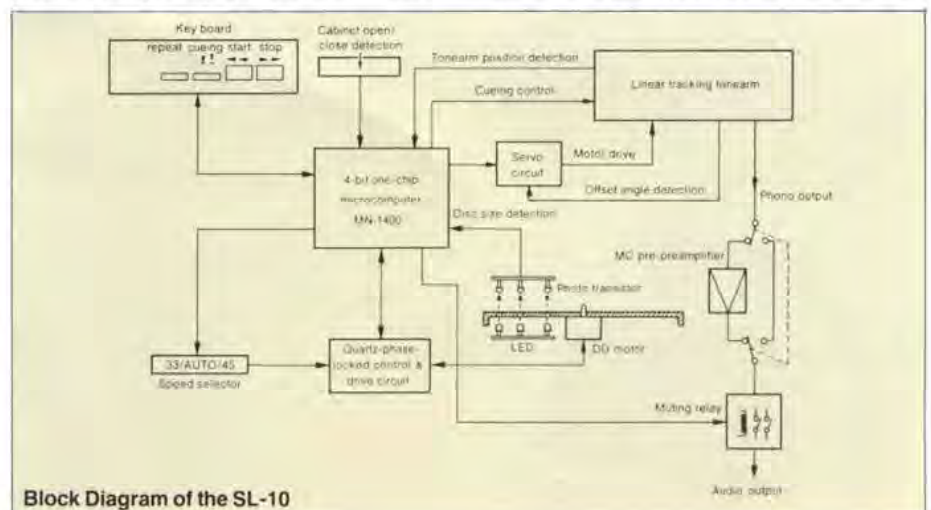

Block Diagram of the SL-10

need for an anti-skating force device. Instead of the conventional ball bearings or rollers, this arm employs a slide bearing having a very low friction coefficient, to avoid undesirable vibrations and allow silent, smooth operation, and precision tonearm transport.

The pivot ball bearing gimbal suspension, and dynamic balance system make it possible to use the tonearm on other than completely flat surfaces, even standing upright, without loss of superb tracking ability, while conventional linear tracking tonearms employing static balance system lack this capability and need precise adjustment in horizontal placement of the turntable.

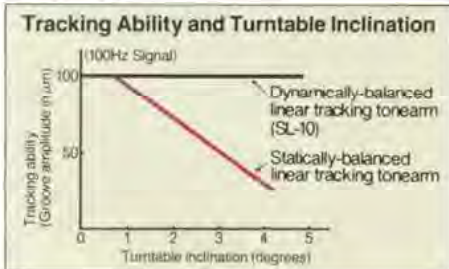

Technics 310MC Moving Coil Cartridge with Coreless Twin Ring Coils and Pure Boron Pipe Cantilever, Built-in MC Pre-Preamp

For this linear tracking tonearm, Technics developed a new moving coil cartridge. This new cartridge, the 310MC, features a coreless twin-ring coil structure that avoids the magnetic loss and distortion found in conventional moving coil cartridges that do employ cores for their coils. Thanks to the high rigidity and low mass of the pure boron pipe cantilever*, an incredibly low effective moving mass of 0.23 mg is realized in this MC cartridge, making possible its extremely linear, flat frequency response and superb tracking ability.

Our unique TTDD damper maintains consistent visco-elasticity independent of ambient temperature, a feature rarely found in any high performance cartridge.

The tonearm and cartridge are designed to be a perfect match, and the slide-in locking design makes it easy to replace the cartridge when necessary.

Built into the SL-10 is a low-noise MC pre-amp section to allow the unit to be used with any preamp. The built-in pre-amp can be bypassed with a switch, should the user wish instead to use another pre-amp, or step-up transformer.

*Technics developed world's first pure boron pipe cantilever in 1978 and furnished it in several high-end cartridges. A new crystal growing technique is used to form pure boron pipe into which the diamond stylus is mounted by means of a laser beam drilling technology.



- ① Growing crystals of pure boron into a pipe configuration
- ② Precision processing of tip mounting hole using a laser beam
- ③ Mounting nude diamond tip on the pipe.

Other Features

- Employs Technics' highly dependable integral rotor/platter DD motor with full-cycle detection FG servo system.
- The precision die-cast aluminum cabinet design with sealing upper and lower halves help prevent external vibration. To prevent acoustic feedback, even the underside of the platter is dampened, and the record is played in a sealed chamber totally isolated from the environment.
- DC power supply terminal is supplied. When used outdoors, car battery or other DC power supply can be used to power the SL-10.
- Comes with record stabilizer for steady play. Built into the upper cabinet is a disc stabilizer that holds down the disc when the unit is closed for operation. The strobe is on the outside circumference of the stabilizer.
- Built-in 45 rpm adaptor. Pops up for playing discs with large center holes. Stays out of the way for LP play.
- Dial scale confirms position of tonearm over record surface. Located on exterior cabinet.

Technics changes the face of turntable technology . . . again.



Simple Basic Operation Combined with Extensive Automatic Control

Basic operation of the turntable is extremely simple. The user merely places the record on the platter, closes the top, and presses the start button. Then, by just opening the top, at any point during turntable operation, the tonearm will automatically rise and return to the arm rest; there is no need to press any other buttons. The simplicity of operation is made possible by very extensive automatic control systems.

●Automatic judgment of correct record speed

Full size LP records are played at 33-1/3 rpm; single discs are played at 45 rpm without the need for any user adjustments. Nevertheless, the user can override this automatic system to play larger size forty-fives, or smaller 33-1/3 discs by using the inside speed selector manually.



●Auto lead-in and auto disc size selection

Press the start key once and the optoelectronic sensor will automatically detect the size of the record and move the tonearm over the outer edge of the record, lower the cartridge, and begin play. If there is no record on the platter, the tonearm will not be lowered onto the platter. In fact, it will not move at all.

●Search capability to control forward and backward movement of the tonearm, and the speed of movement

Two buttons on the front panel with left and right pointing LED arrows may be used to move the tonearm back and forth to the point where the user wishes to begin playing the record.

When pressed and held, the start key makes the arm move inwards, toward the lead-in grooves. Once the desired point has been found, the user releases the key and presses the cueing key, and the cartridge is automatically lowered onto the record surface.

The arm moves slowly when the user presses lightly on these buttons (one LED lights up); it moves faster when the buttons are pressed harder (two LEDs light up).

There is a dial scale on top of the cabinet to let the user know where on the record surface the arm has moved to. Thanks to an interlocking system, the arm will not move inward or outward further than the lead-out or lead-in grooves, thus protecting the stylus from accidental damage.

●Repeat from the beginning during play

During play, if the start key is pressed, the arm will go back to the lead-in grooves and begin play again from the beginning. Even if this key is pressed in the middle of auto-return operation, the arm will still go back to the lead-in grooves and begin playing.

●Auto-stop

If the stop key is pressed during play, the tonearm will rise and return to the arm rest, and the turntable will stop. The same action happens if the cabinet is opened during play.

●Auto return

An optoelectronic system detects the end of the record, without physical contact, and tells the tonearm control system to return the arm to the arm rest. Since no physical force is involved in the detection process, the cartridge and stylus perform at their optimum from the beginning of the record, all the way to the end.

●Auto-cueing, muting

Pressing the front panel cueing key controls up and down movement of the tonearm automatically in the middle of record groove; the user never touches the tonearm directly, or

needs to open up the cabinet during the cueing operation. A special electronic muting circuit instantaneously cuts off the signal at the moment the stylus contacts or leaves the grooves, thereby preventing noise during cueing.

●Automatic repeat

Pressing the repeat key makes the unit play the same record over again. However, if the stop key is pressed during a repeat play, the turntable will stop and the tonearm will automatically return to the arm rest.



- ① Power on/off
- ② Rotational speed indicator
- ③ Repeat key
- ④ Cueing key
- ⑤ Start key
- ⑥ Stop key

Technical Specifications

TURNTABLE SECTION

Type	Quartz-phase-locked control direct drive fully-automatic with automatic speed and disc size selection, auto lead-in, automatic detection of disc, 2-speed search function of tonearm, auto-return, auto-stop and repeat
Motor	Ultra-low-speed brushless DC motor
Turntable platter	Aluminum diecast diameter 30 cm (12")
Turntable speeds	33-1/3 and 45 rpm automatic selection (manual selection possible)
Speed accuracy	Within $\pm 0.002\%$
Wow & flutter	0.012% WRMS* 0.025% WRMS (JIS C5521) $\pm 0.035\%$ peak (IEC 98A weighted)
Rumble	-78 dB DIN B (IEC 98A weighted) -56 dB DIN A (IEC 98A unweighted)

TONARM SECTION

Type	Dynamic-balanced linear-tracking gimbal-suspension tonearm
Effective length	105 mm (4-1/8")
Tracking error angle	Within $\pm 0.1^\circ$

Effective mass	9 g (including cartridge)
Resonance frequency	12 Hz
Tonearm drive motor	Coreless DC motor

CARTRIDGE SECTION

Type	Moving coil (MC) stereo cartridge with coreless twin ring coils
Cantilever	Pure boron pipe cantilever
Damper	TTDD (Technics Temperature Defense Damper)
Frequency response	10~60,000 Hz 10~10,000 Hz ± 0.5 dB
Temperature characteristics (5 $^\circ$ ~35 $^\circ$ C)	± 1 dB at 10 kHz (Standard 0 dB 1 kHz/20 $^\circ$ C)
Output voltage	0.2 mV at 1 kHz, 5 cm/sec, zero to peak, lateral velocity (0.56 mV at 1 kHz, 10 cm/sec, zero to peak, 45 $^\circ$ velocity, DIN 45 500)
Channel separation	More than 25 dB (1 kHz), More than 20 dB (10 kHz)
Channel balance	Within 1 dB (1 kHz)
DC resistance	30 ohms
Impedance	30 ohms (purely ohmic)
Compliance	12×10^{-6} cm/dyne, 100 Hz

Vertical tracking angle	20 $^\circ$
Tracking force	1.25 g ± 0.25 g
Stylus tip	0.1 mm square nude diamond, 0.2 \times 0.7 mil elliptical

Effective moving mass	0.23 mg
Weight	6 g
Replacement cartridge	EPS-310MC

MC PRE-PREAMPLIFIER SECTION

(Specifications excluding cartridge)	
S/N ratio	70 dB (IHF A)
Frequency response	20 Hz~20 kHz, ± 0.5 dB
Rated output	2.5 mV
Total harmonic distortion	0.02% (at rated output)

GENERAL

Power supply	AC 120 V, 50/60 Hz DC 12 V
Power consumption	18 W
Dimensions (H \times W \times D)	31.5 \times 31.5 \times 8.8 cm (12-1/2" \times 12-1/2" \times 3-1/2")
Weight	6.5 kg (14.3 lb)

* Measured by obtaining signal from built-in frequency generator of motor assembly.

Technics

Panasonic Company

Division of Matsushita Electric Corporation of America

EXECUTIVE OFFICES: One Panasonic Way, Secaucus, New Jersey 07094 (201) 348-7000

PANASONIC NORTHEASTERN GROUP: 50 Meadowlands Parkway, Secaucus, New Jersey 07094 (201) 348-7000

PANASONIC MIDWEST GROUP: 425 E. Algonquin Road, Arlington Heights, Ill. 60005 (312) 364-7900

PANASONIC SOUTHERN GROUP: #2 MECA Way, Norcross, Georgia 30093 (404) 923-9700

PANASONIC WEST, INC.: 8383 Wilshire Blvd., Beverly Hills, Calif. 90211 (213) 655-1111

PANASONIC SALES COMPANY: Ave. 65 de Infanteria, Km. 9.7, Victoria Industrial Park, Carolina, Puerto Rico 00630 (809) 769-4320

PANASONIC HAWAII, INC.: 320 Waiakamilo Road, Honolulu, Hawaii 96817 (808) 847-5361

Matsushita Electric of Canada Limited: 5770 Ambler Drive, Mississauga, Ontario L4W 2T3 (416) 624-5010