

AX-592/AX-892

YAMAHA

PRINTED CIRCUIT BOARD (Foil side)

① and ② : TEST POINT WAVEFORMS(AX-592→ See page 22) (AX-892→ See page 24)

Semiconductor Location

Ref. No.	Location	Ref. No.	Location	Ref. No.	Location	Ref. No.	Location	Ref. No.	Location	Ref. No.	Location
D301	B5	D313	D5	Q301	B5	Q313	F5	Q323	C5	Q335	C4
D302	B5	D314	D5	Q302	B5	Q314	F5	Q324	C4	Q336	C4
D303	C5	D315	D5	Q303	B5	Q315	D5	Q325	C4	Q337	F5
D304	E5	D319	F5	Q304	B5	Q316	D5	Q326	C4		
D305	E5	D320	F5	Q307	D4	Q317	D5	Q327	C5		
D308	E4	D321	F5	Q308	D4	Q318	D5	Q328	C4		
D309	D5	IC301	C5	Q309	D4	Q319	D5	Q329	C4		
D310	D5	IC307	E5	Q310	D4	Q320	D5	Q330	C4		
D311	E5	IC308	E5	Q311	F5	Q321	D5	Q333	C5		
D312	E5	IC309	E5	Q312	E5	Q322	E5	Q334	C4		

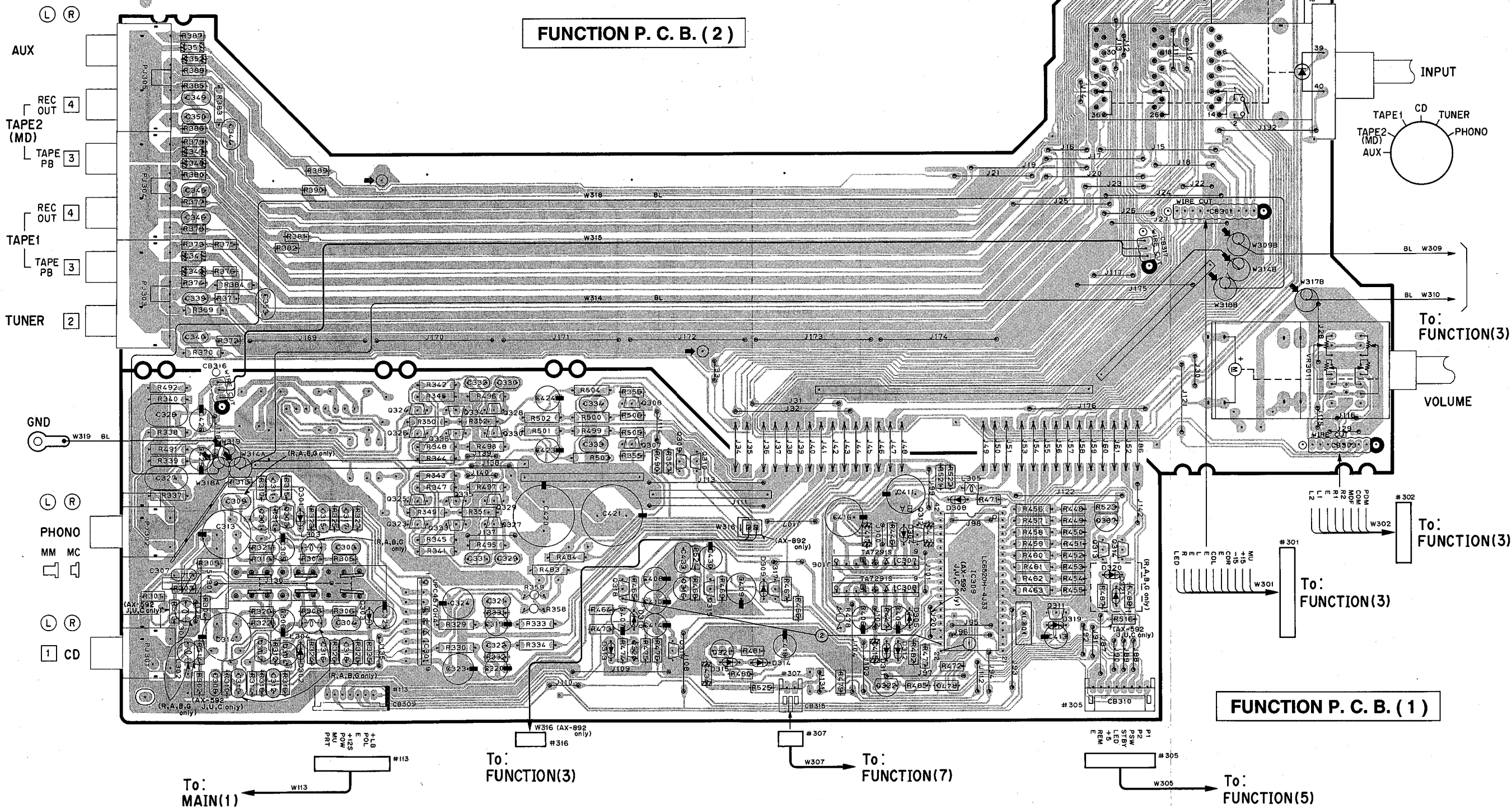

■ PRINTED CIRCUIT BOARD (Foil side)

FUNCTION P. C. B. (4)

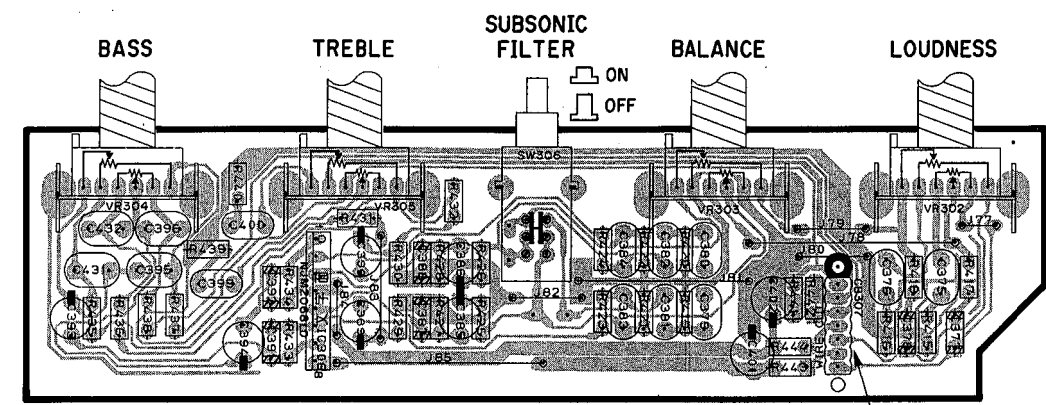

● AX-892 only
FUNCTION P. C. B. (11)

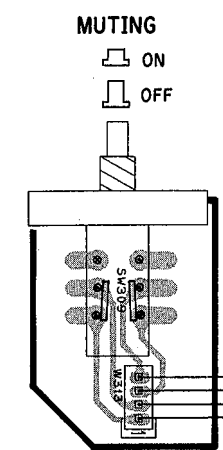

FUNCTION P. C. B. (6)

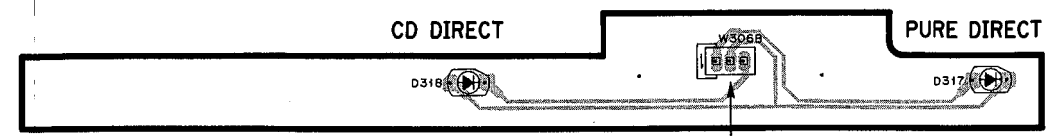

FUNCTION P. C. B. (3)

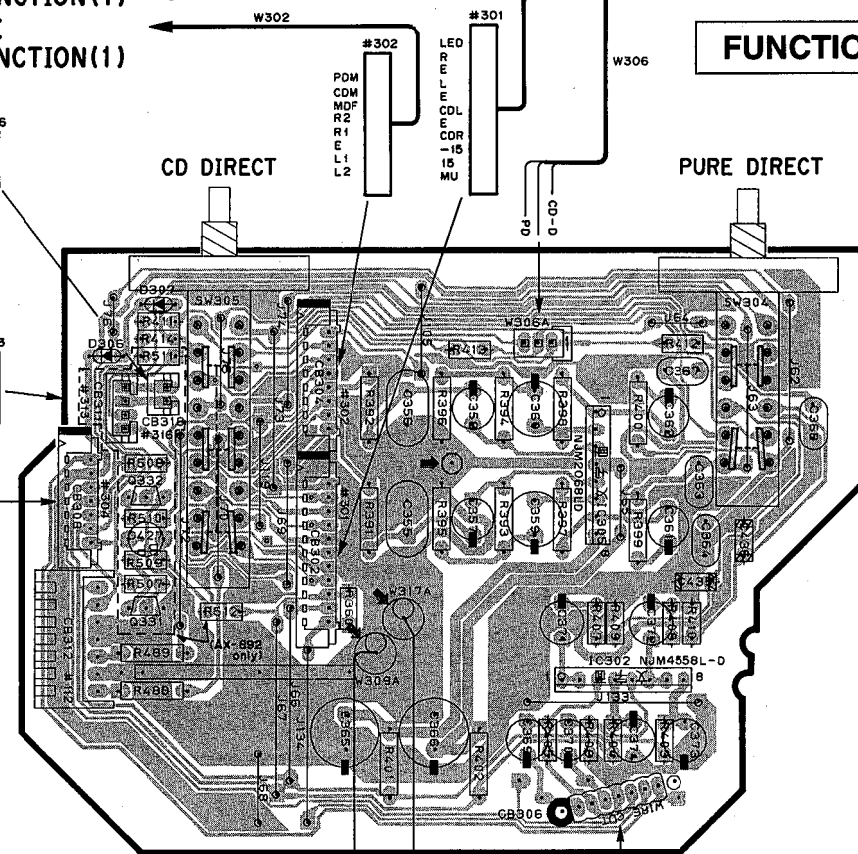

● Semiconductor Location

Ref. No.	Location
D306	E3
D307	E2
D316	B3
D317	F1
D318	G1
D322	B5
IC305	G3
IC306	B2
Q305	G5
Q306	G5
Q331	E3
Q332	E3

FUNCTION P. C. B. (7)

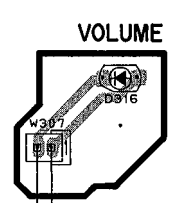

FUNCTION P. C. B. (5)

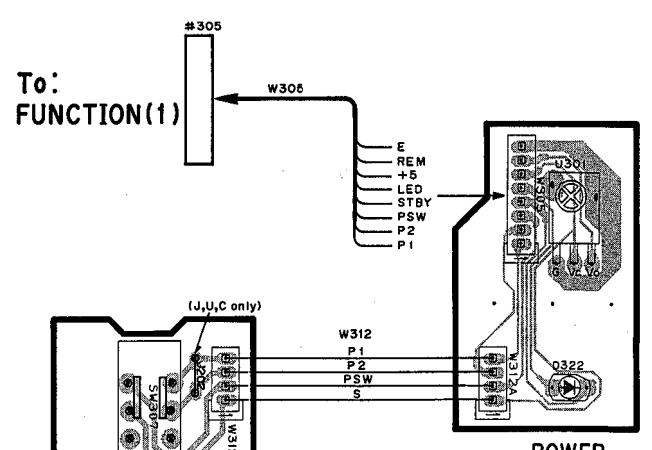

FUNCTION P. C. B. (9)

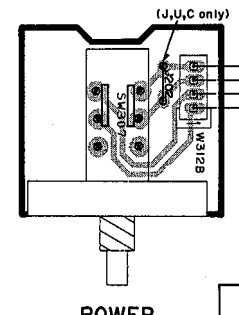

FUNCTION P. C. B. (8)

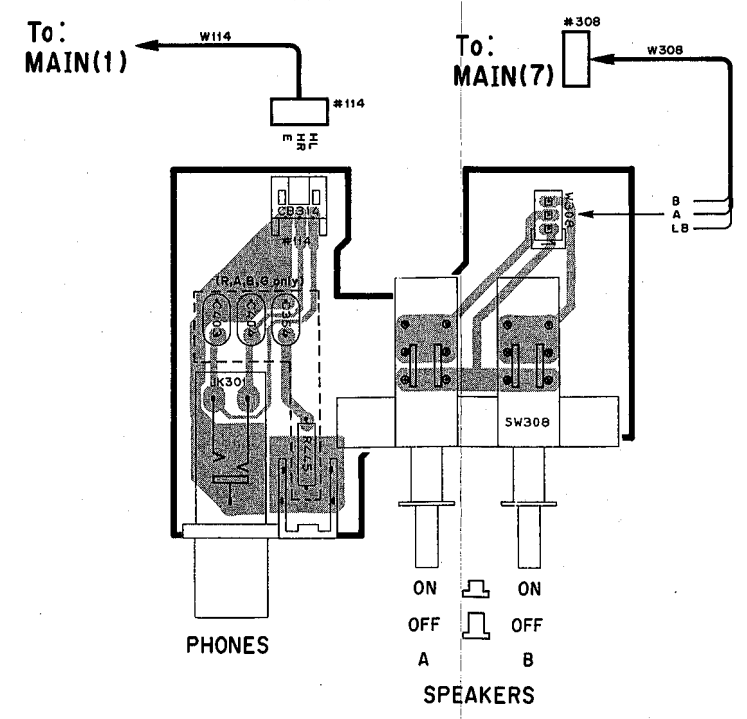

FUNCTION P. C. B. (10)

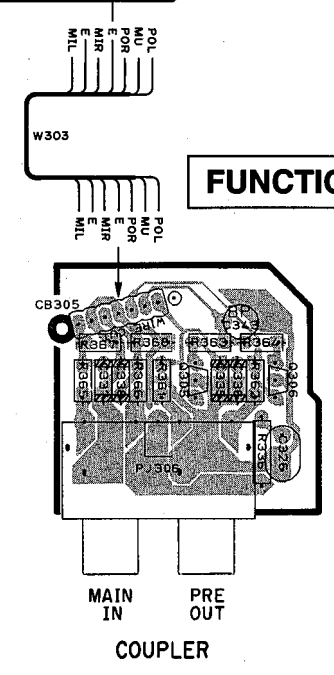

■ AX-592 PRINTED CIRCUIT BOARD (Foil side)

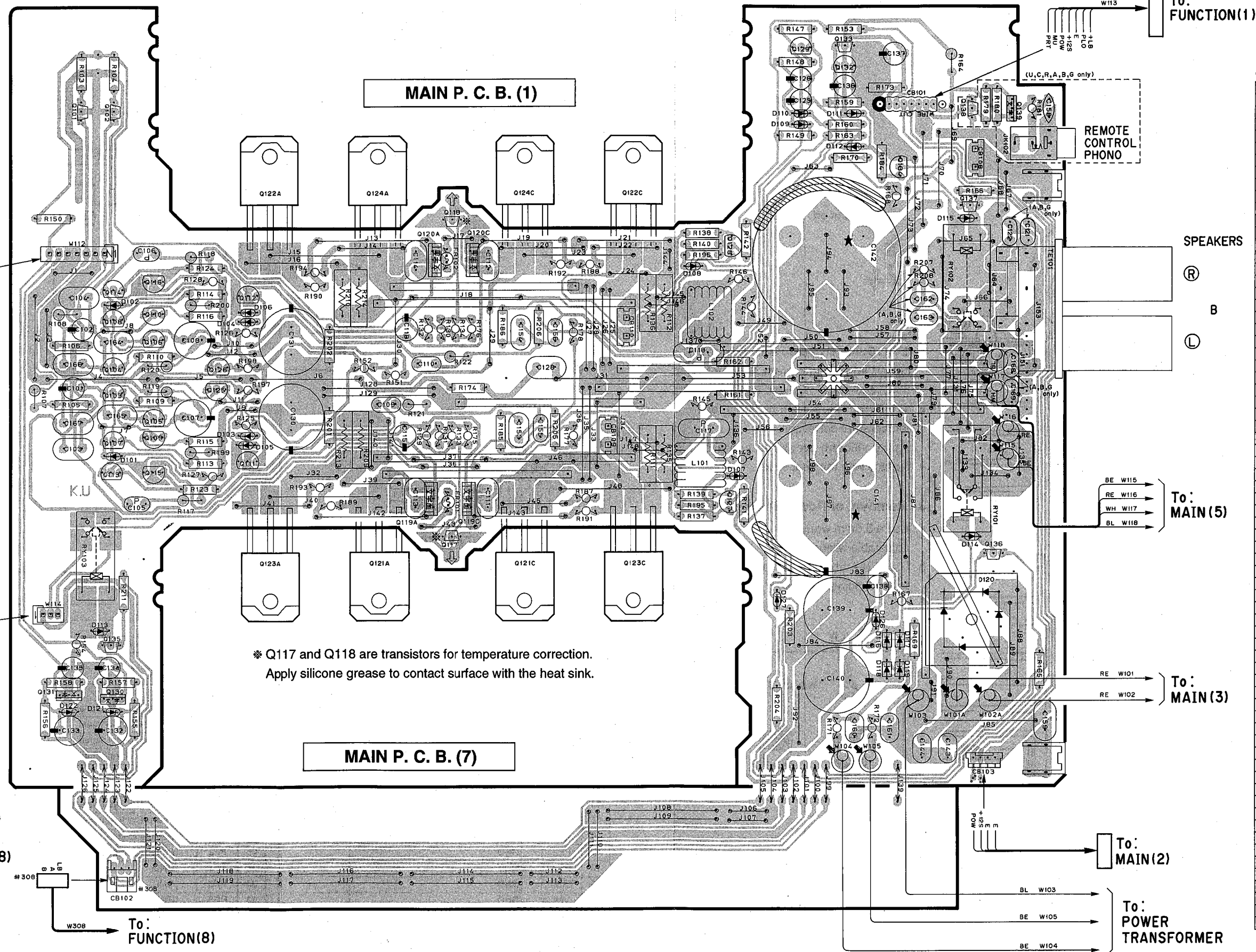

● Semiconductor Location

Ref. No.	Location
D101	B3
D102	B3
D103	B3
D104	B3
D105	B3
D106	B3
D107	E3
D108	E2
D109	E2
D110	E2
D111	E2
D112	E2
D113	B4
D114	F4
D115	F2
D116	E4
D117	F4
D118	E4
D119	F4
D120	F4
D121	B5
D122	A5
D126	E4
D127	E4
Q101	A2
Q102	B2
Q103	B3
Q104	B3
Q105	B3
Q106	B3
Q107	B3
Q108	B3
Q109	B3
Q110	B3
Q111	B3
Q112	B3
Q113	B3
Q114	B3
Q115	B3
Q116	B3
Q117	C4
Q118	C2
Q119A	C4
Q119C	C4
Q120A	C2
Q120C	C2
Q121A	C4
Q121C	D4
Q122A	B2
Q122C	D2
Q123A	B4
Q123C	D4
Q124A	C2
Q124C	D2
Q125	B3
Q126	B3
Q127	E4
Q128	E2
Q129	E1
Q130	B5
Q131	A5
Q132	E1
Q133	E1
Q134	F2
Q135	B4
Q136	F4
Q137	F2
Q138	F2
Q139	F2

AX-892

AX-892 PRINTED CIRCUIT BOARD (Foil side)

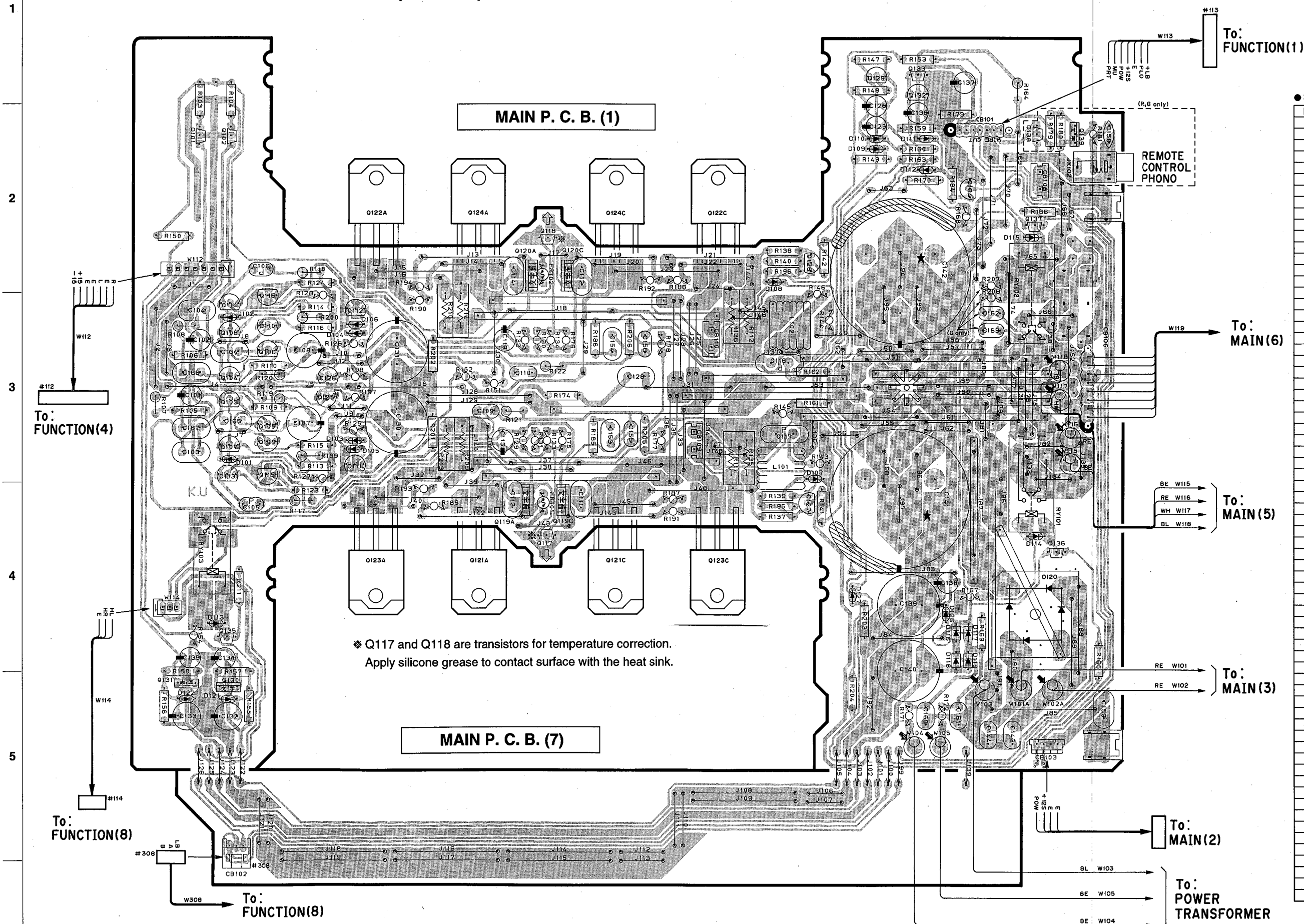

● Semiconductor Location

Ref. No.	Location
D101	B3
D102	B3
D103	B3
D104	B3
D105	B3
D106	B3
D107	E3
D108	E2
D109	E2
D110	E2
D111	E2
D112	E2
D113	B4
D114	F4
D115	F2
D116	E4
D117	F4
D118	E4
D119	F4
D120	F4
D121	B5
D122	A5
D126	E4
D127	E4
Q101	A2
Q102	B2
Q103	B3
Q104	B3
Q105	B3
Q106	B3
Q107	B3
Q108	B3
Q109	B3
Q110	B3
Q111	B3
Q112	B3
Q113	B3
Q114	B3
Q115	B3
Q116	B3
Q117	C4
Q118	C2
Q119A	C4
Q119C	C4
Q120A	C2
Q121A	C4
Q121C	D4
Q122A	B2
Q122C	D2
Q123A	B4
Q123C	D4
Q124A	C2
Q124C	D2
Q125	B3
Q126	B3
Q127	E4
Q128	E2
Q129	E1
Q130	B5
Q131	A5
Q132	E1
Q133	E1
Q134	F2
Q135	B4
Q136	F4
Q137	F2
Q138	F2
Q139	F2

■ PRINTED CIRCUIT BOARD (Foil side)

● J, U, C and R model

MAIN P. C. B. (2)

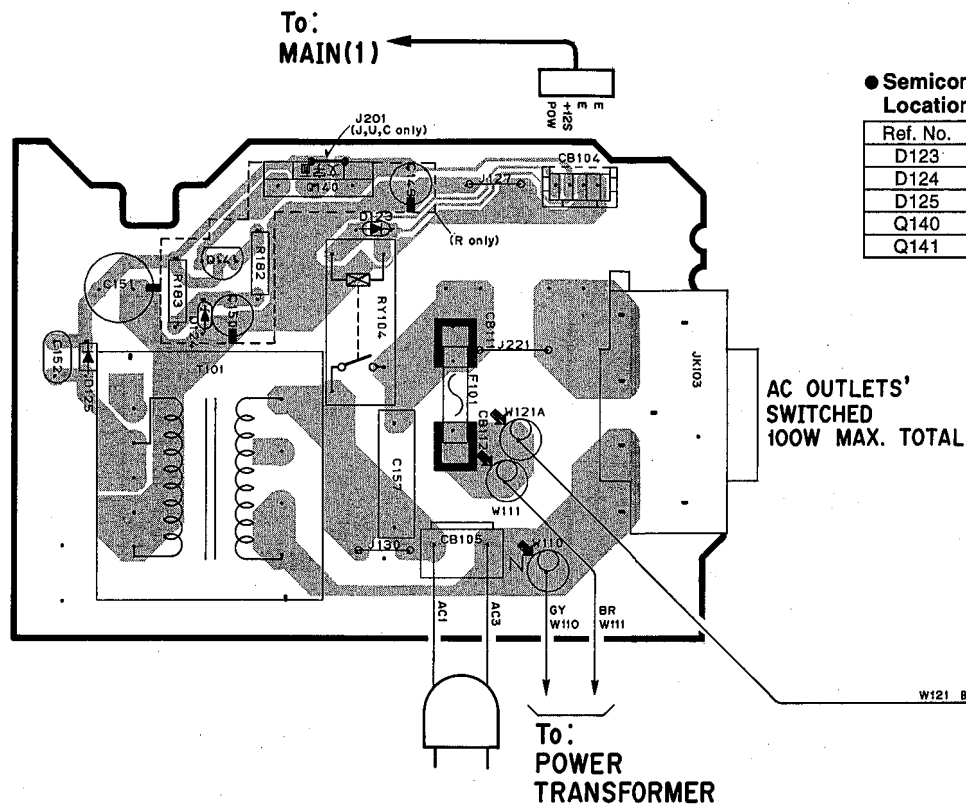

● Semiconductor Location

Ref. No.	Location
D123	B2
D124	A2
D125	A2
Q140	B2
Q141	A2

Voltage	Switch Position
240V	1-2 / 5-6
220V	2-3 / 6-7
110V	3-4 / 7-8
120V	4-5 / 8-1

MAIN P. C. B. (5)

AX-592
AX-892

● R model only

MAIN P. C. B. (4)

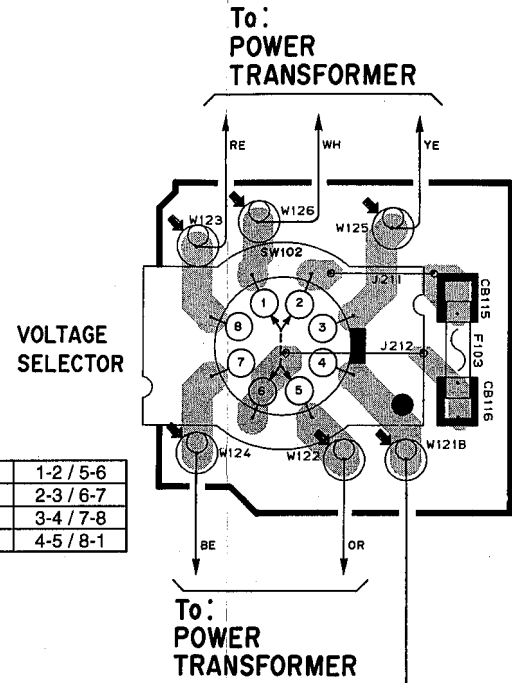

MAIN P. C. B. (3)

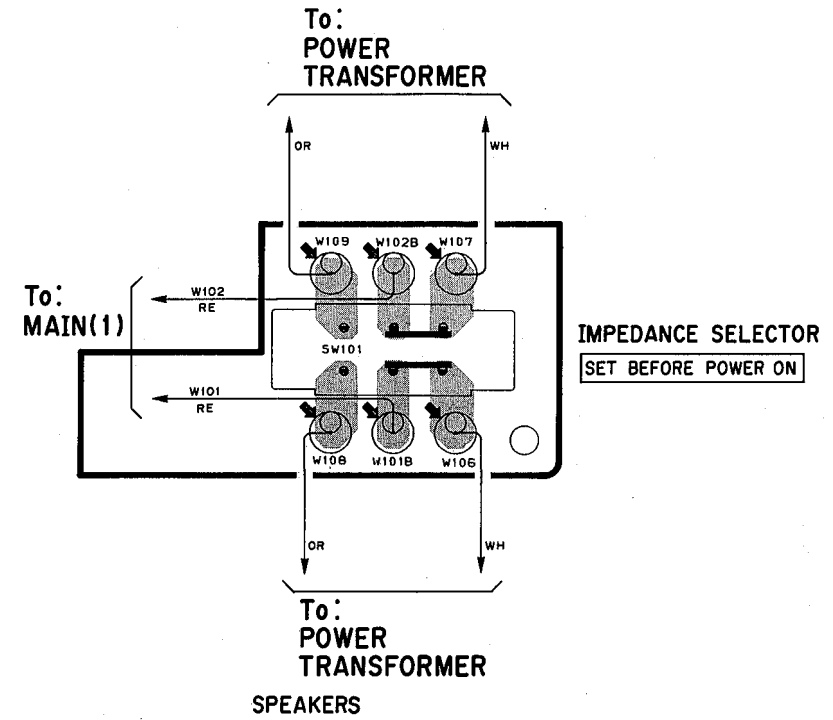

● A, B and G model

MAIN P. C. B. (2)

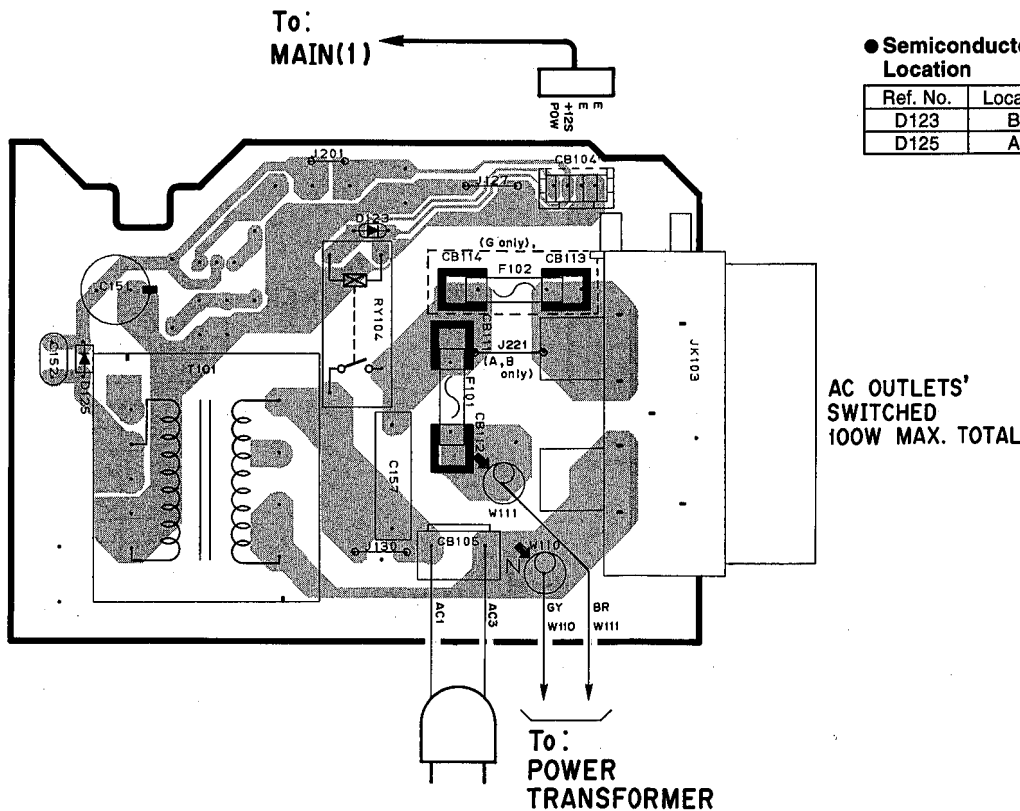

● Semiconductor Location

Ref. No.	Location
D123	B4
D125	A5

● AX-892 only

MAIN P. C. B. (6)

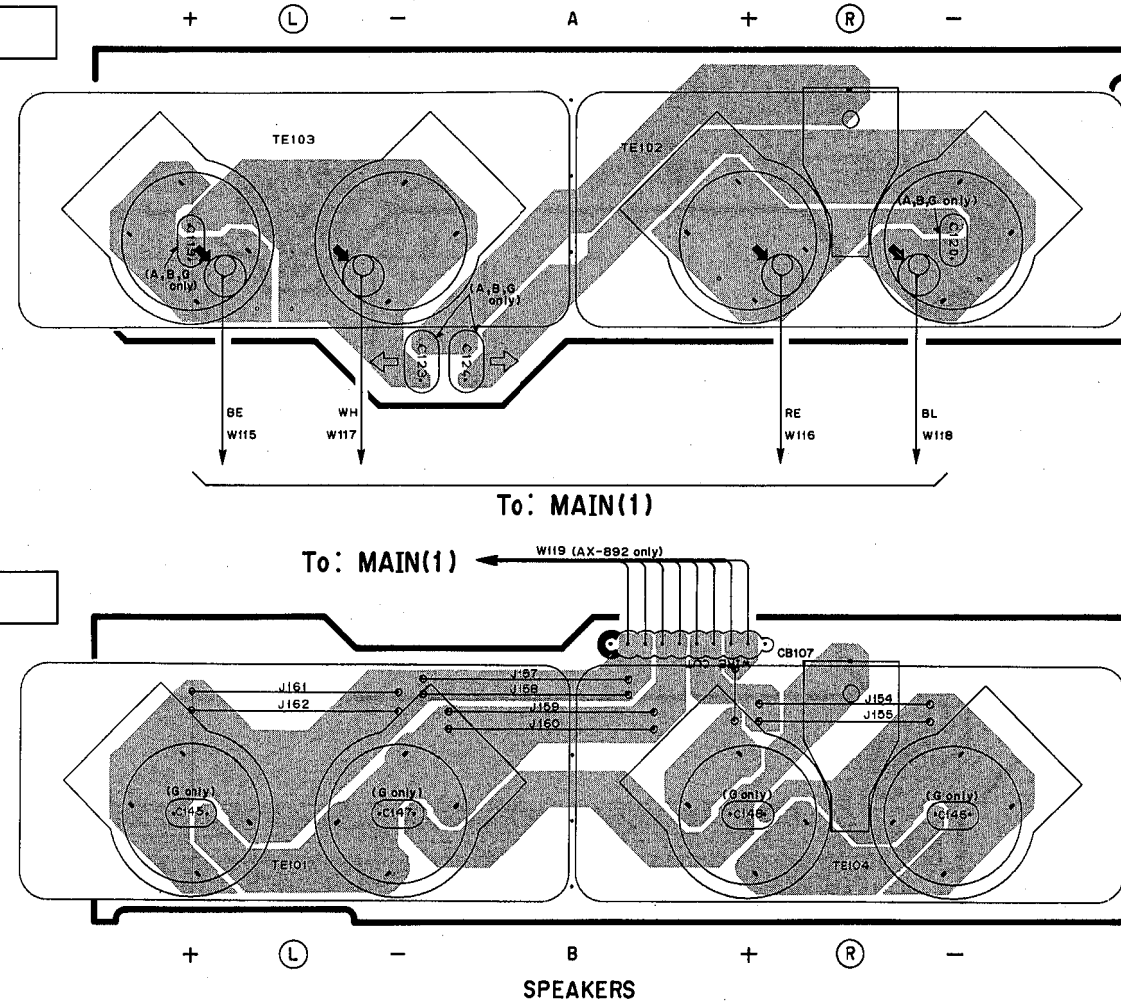

■ TO SERVICE PERSONNEL

1. Critical Components information.

Components having special characteristics are marked  and must be replaced with parts having specifications equal to those originally installed.

2. Leakage Current Measurement (For 120V Model only). When service has been completed, it is imperative that you verify that all exposed conductive surfaces are properly insulated from supply circuits.

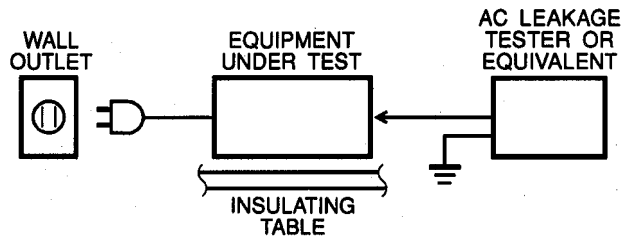

- Meter impedance should be equivalent to 1500 ohm shunted by 0.15uF.
- Leakage current must not exceed 0.5mA.
- Be sure to test for leakage with the AC plug in both polarities.



"CAUTION"

"F101 : FOR CONTINUED PROTECTION AGAINST RISK OF FIRE, REPLACE ONLY WITH SAME TYPE 7.0A, 125V FUSE"
"F103 : FOR CONTINUED PROTECTION AGAINST RISK OF FIRE, REPLACE ONLY WITH SAME TYPE 2.5A, 250V FUSE"

WARNING: CHEMICAL CONTENT NOTICE!

The solder used in the production of this product contains LEAD. In addition, other electrical/electronic and/or plastic (where applicable) components may also contain traces of chemicals found by the California Health and Welfare Agency (and possibly other entities) to cause cancer and/or birth defects or other reproductive harm.

DO NOT PLACE SOLDER, ELECTRICAL/ELECTRONIC OR PLASTIC COMPONENTS IN YOUR MOUTH FOR ANY REASON WHATSOEVER!

Avoid prolonged, unprotected contact between solder and your skin! When soldering, do not inhale solder fumes or expose eyes to solder/flux vapor!

If you come in contact with solder or components located inside the enclosure of this product, wash your hands before handling food.

■ REMOTE CONTROL PANEL

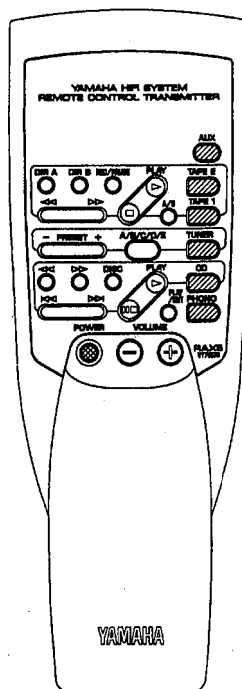

FRONT PANELS

▼ AX-592

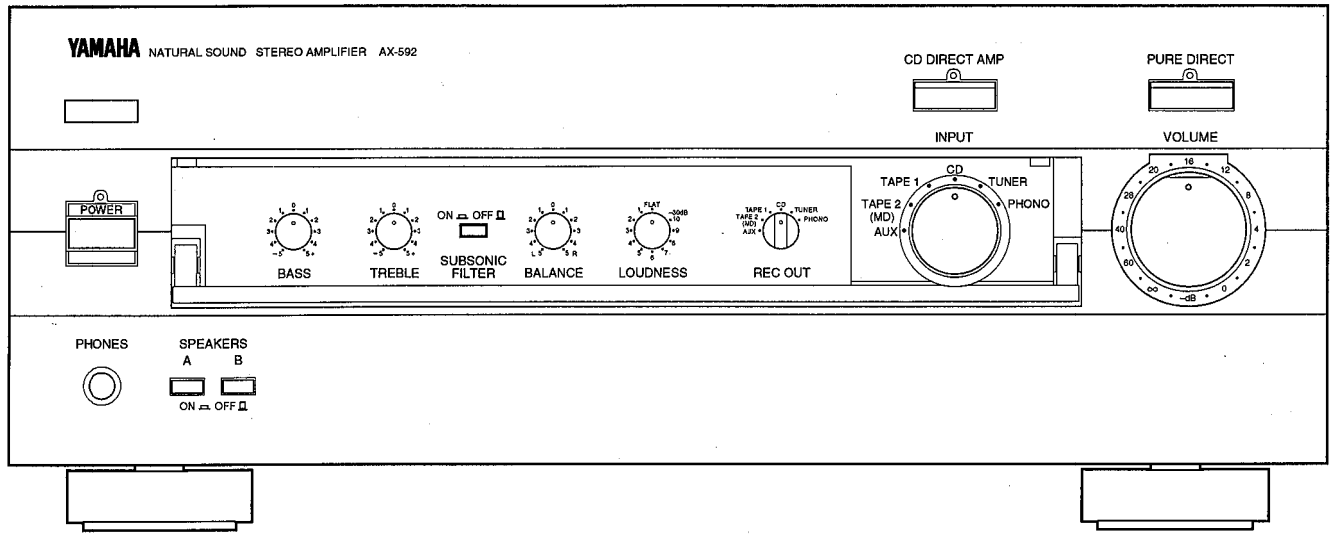

▼ AX-892

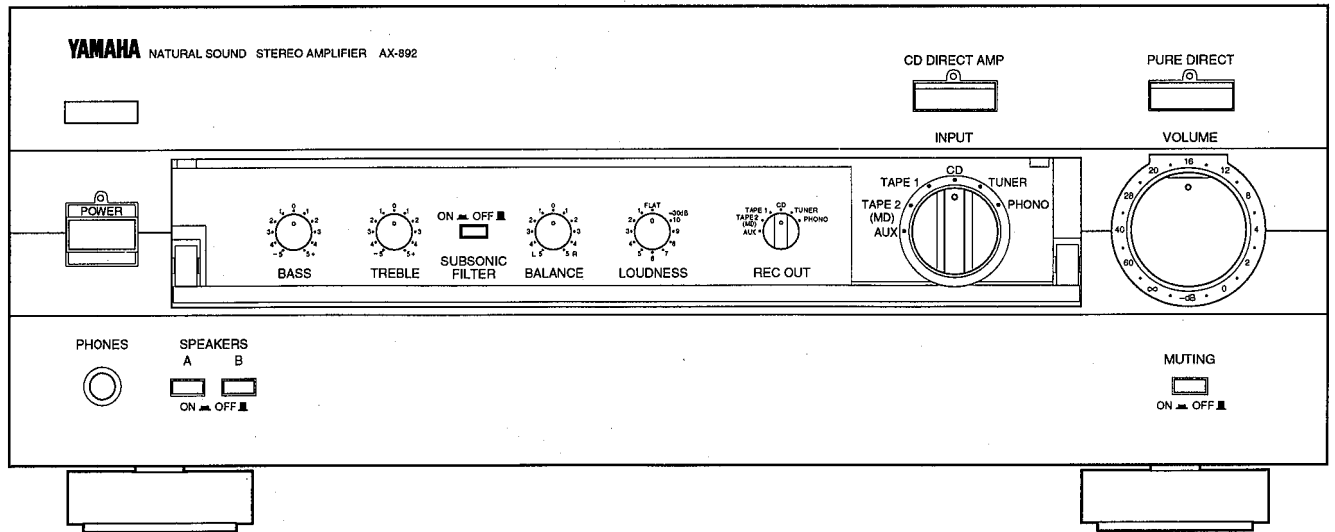

AX-592
AX-892

REAR PANELS

▼ **AX-592 U model**

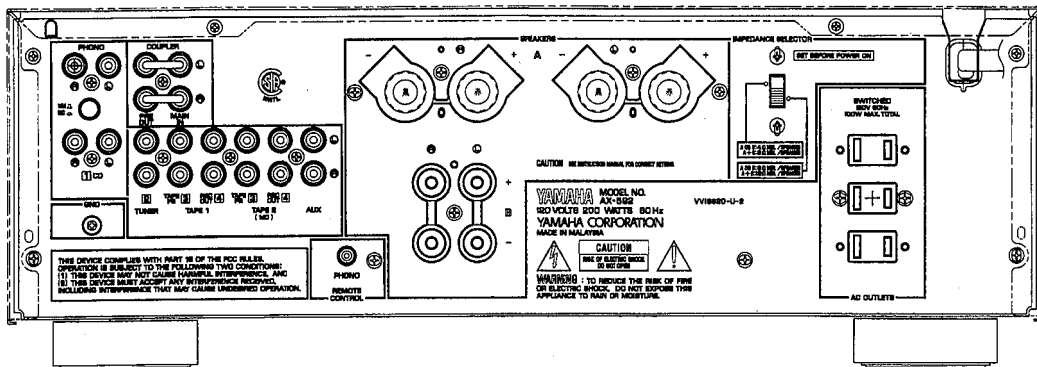

▼ **AX-592 C model**

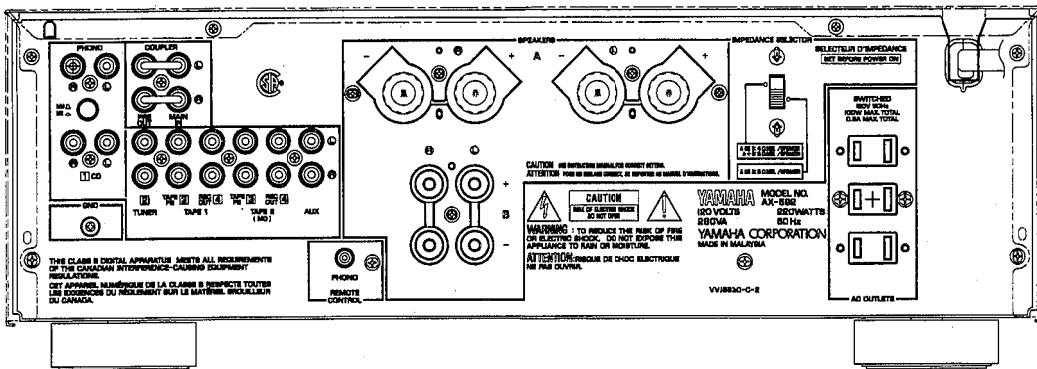

▼ **AX-592 R model**

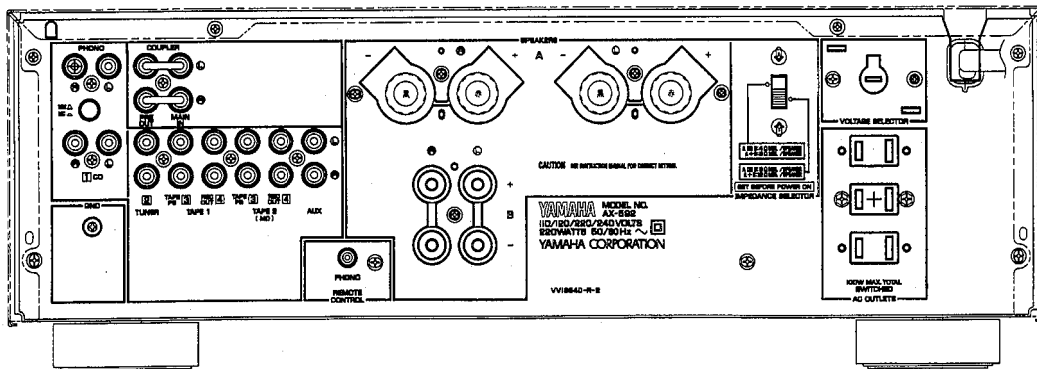

▼ **AX-592 A model**

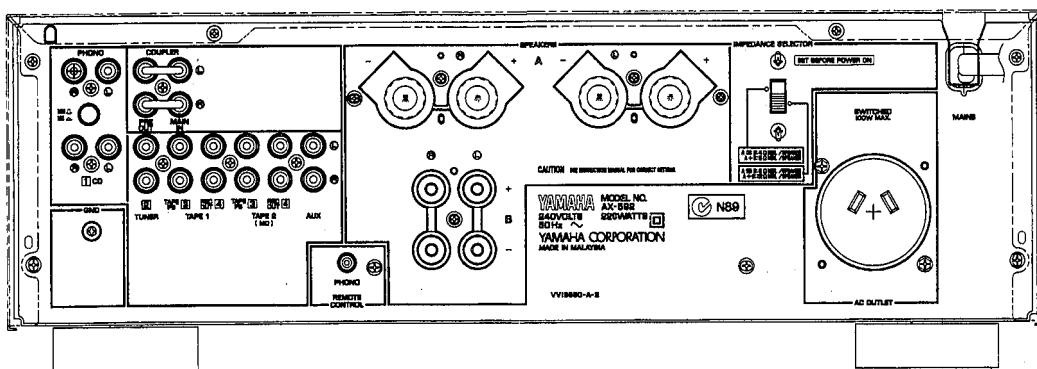

AX-592

AX-592/AX-892

AX-892

▼ AX-592 B model

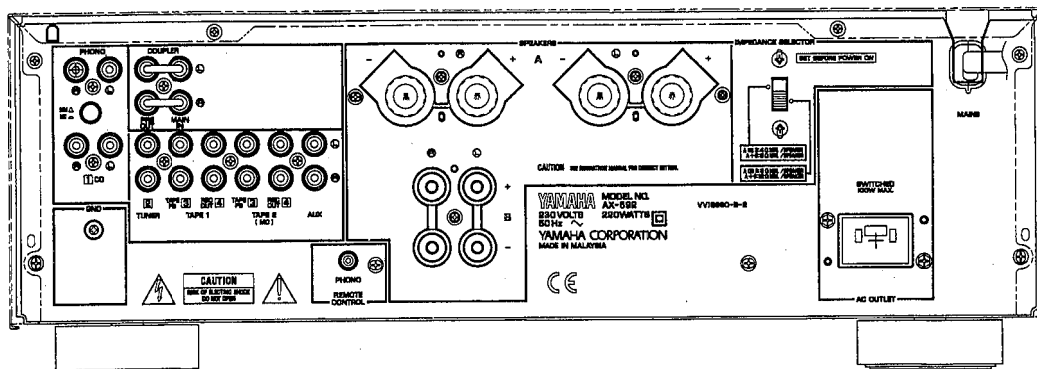

▼ AX-592 G model

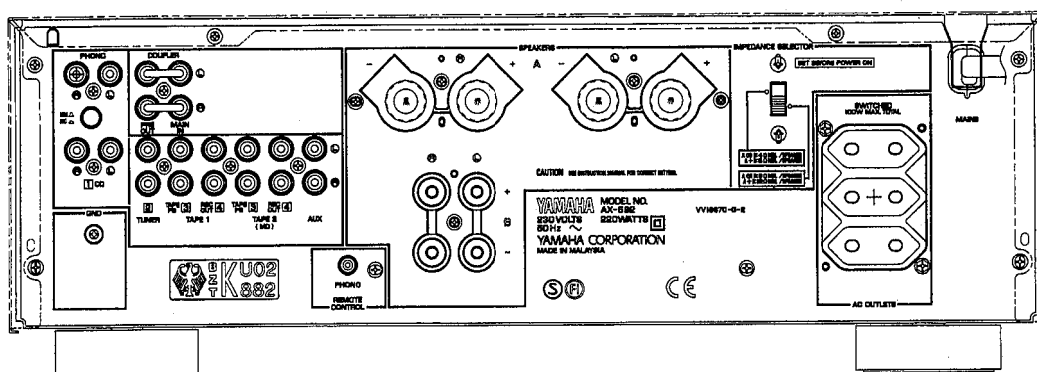

▼ AX-892 R model

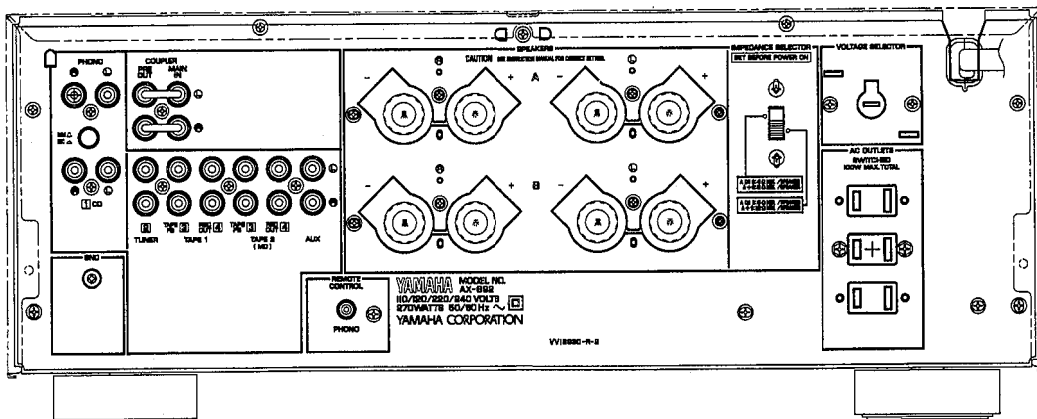

▼ AX-892 G model

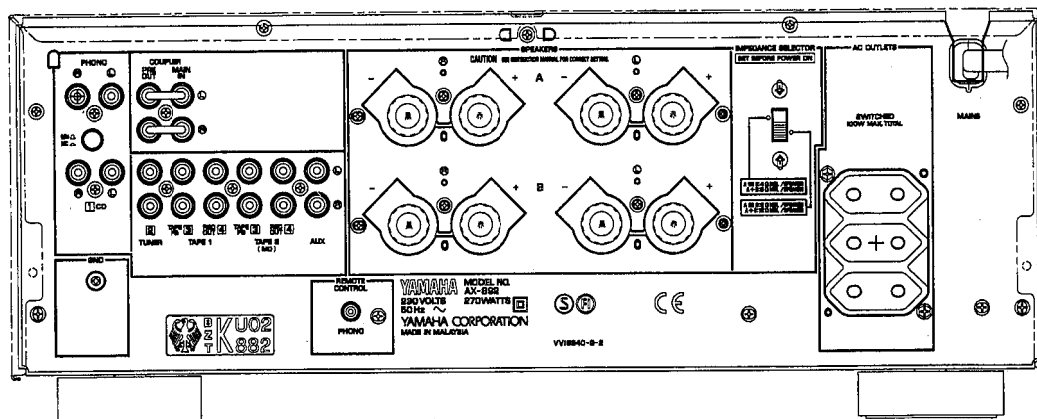

■ AX-592 SPECIFICATIONS

■ AUDIO SECTION

Minimum RMS output Power per Channel	
20Hz to 20kHz, 0.015% THD, 8Ω	100W+100W
20Hz to 20kHz, 0.03% THD, 6Ω	120W+120W
Dynamic Power Per Channel(IHF)	
8/6/4/2Ω	140/170/220/290W
DIN Standard Output Power Per Channel	
G model only	
1kHz, 0.7% THD, 4Ω	155W
IEC Power	
G model only	
1kHz, 0.015% THD, 6Ω	110W
Power Band Width	
0.03% THD, 50W, 8Ω	10Hz to 50kHz
Damping Factor (SP-A)	
20Hz to 20kHz, 8Ω	320 or more
Maximum Power (EIAJ)	
R model only	
1kHz, 10% THD, 8/6Ω	145/170W
Input Sensitivity/Impedance	
PHONO MC	160μV/250Ω
PHONO MM	2.5mV/47kΩ
CD etc	150mV/47kΩ
MAIN IN	1V/30kΩ
Maximum input Signal Level	
PHONO MC, 1kHz, 0.007% THD	10mV
PHONO MM, 1kHz, 0.007% THD	150mV
Output Level/Impedance	
REC OUT	150mV/600Ω
PRE OUT	1V/1.2kΩ
Headphone Jack Rated Output/Impedance	
0.015% THD, RL=8Ω	0.33V/680Ω
Frequency Response(20Hz to 20kHz)	
CD etc	0±0.5dB
MAIN IN	0±0.5dB
RIAA Equalization Deviation	
PHONO MC	0±0.5dB
PHONO MM	0±0.3dB
Total Harmonic Distortion(20Hz to 20kHz)	
PHONO MC to REC OUT (3V)	0.007%
PHONO MM to REC OUT (3V)	0.003%
CD etc to PRE OUT(1V)	0.005%
CD etc to SP OUT(50W/8Ω)	0.008%
Signal-to-Noise Ratio(IHF-A-Network)	
PHONO MC, (500μV Input Shorted)	76dB
PHONO MM, (5mV Input Shorted)	92dB
CD, CD DIRECT AMP ON (Shorted)	110dB
Residual Noise(IHF-A-Network)	
CD DIRECT AMP ON	35μV
PURE DIRECT ON	90μV
Channel Separation(Vol. -30dB)	
CD etc(Input 5.1kΩ terminated), 1kHz/10kHz	65/50dB
Tone Control Characteristics	
BASS : Boost/Cut	±10dB(20Hz)
: Turnover Frequency	350Hz
TREBLE : Boost/Cut	±10dB(20kHz)
: Turnover Frequency	3.5kHz
Filter Characteristics	
SUBSONIC FILTER	15Hz, -18dB/oct

Continuous Loudness Control

Attenuation (Level related equalization)	-30dB(1kHz)
Gain Tracking Error(0~-60dB)	2dB

■ GENERAL

Power Supply	
U, C models	AC120V, 60Hz
R model	AC110/120/220/240V, 50/60Hz
A model	AC240V, 50Hz
B, G models	AC230V, 50Hz
Power Consumption	
U model	200W
C, R, A, B, G models	220W
AC Outlet	
U, C, R, G models, Switched x 3	100W max(Total)
A, B models, Switched x 1	100W max
Dimensions (W x H x D)	
	435 x 151 x 396mm (17-1/8"x5-15/16"x15-19/32")
Weight	
	10.6kg(23lbs 6oz)
Accessories	
	Remote Control Trasmmitter x 1 Battery (size "AA", "R06") x 2

* Specifications subject to change without notice.

- U U. S. A. model
- C Canadian model
- R General model
- A Australian model
- B British model
- G European model

● DIMENSIONS

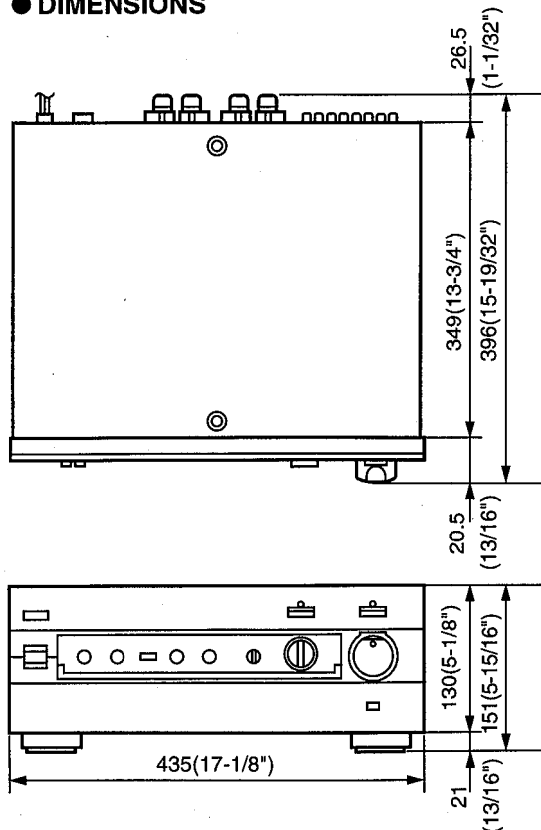

Units: mm (inch)

■ AX-592 INTERNAL VIEW

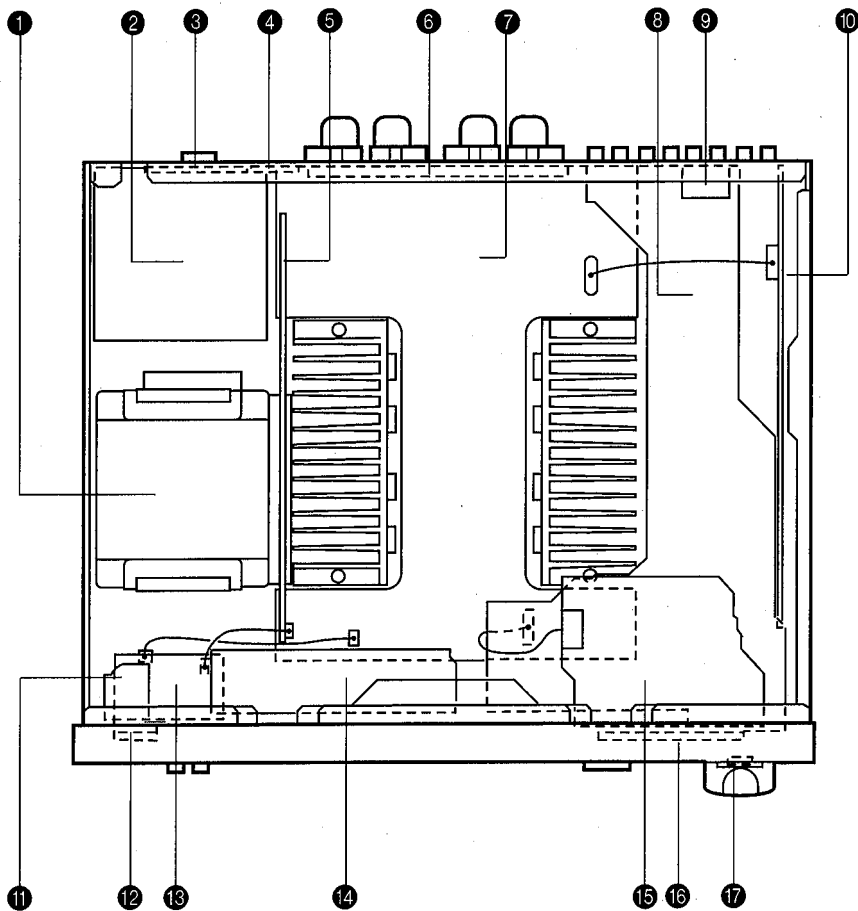

- ① POWER TRANSFORMER
- ② MAIN P.C.B. ASS'Y (2)
- ③ MAIN P.C.B. ASS'Y (4) (R model Only)
- ④ MAIN P.C.B. ASS'Y (3)
- ⑤ MAIN P.C.B. ASS'Y (7)
- ⑥ MAIN P.C.B. ASS'Y (5)
- ⑦ MAIN P.C.B. ASS'Y (1)
- ⑧ FUNCTION P.C.B. ASS'Y (2)
- ⑨ FUNCTION P.C.B. ASS'Y (10)
- ⑩ FUNCTION P.C.B. ASS'Y (1)
- ⑪ FUNCTION P.C.B. ASS'Y (9)
- ⑫ FUNCTION P.C.B. ASS'Y (5)
- ⑬ FUNCTION P.C.B. ASS'Y (8)
- ⑭ FUNCTION P.C.B. ASS'Y (4)
- ⑮ FUNCTION P.C.B. ASS'Y (3)
- ⑯ FUNCTION P.C.B. ASS'Y (6)
- ⑰ FUNCTION P.C.B. ASS'Y (7)

■ AX-592 DISASSEMBLY PROCEDURES

(Remove parts in disassembly order as numbered.)

1. Removal of Top Cover

- a. Remove 4 screws (①) in Fig. 1.
- b. Remove 2 screws (②) in Fig. 1.

2. Removal of Bottom Cover

- a. Remove 9 screws (③) in Fig. 1.
- b. Remove 6 screws (④) in Fig. 1.
- c. Remove 6 screws (⑤) in Fig. 1.

3. Removal of Front Panel

- a. Remove 7 knobs in Fig. 1.
- b. Remove 3 screws (⑥) in Fig. 1.

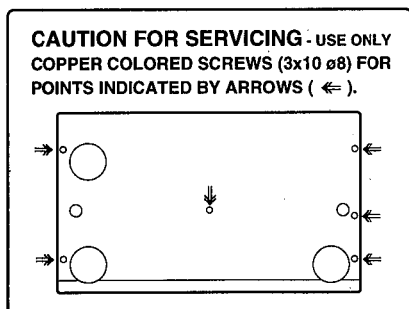
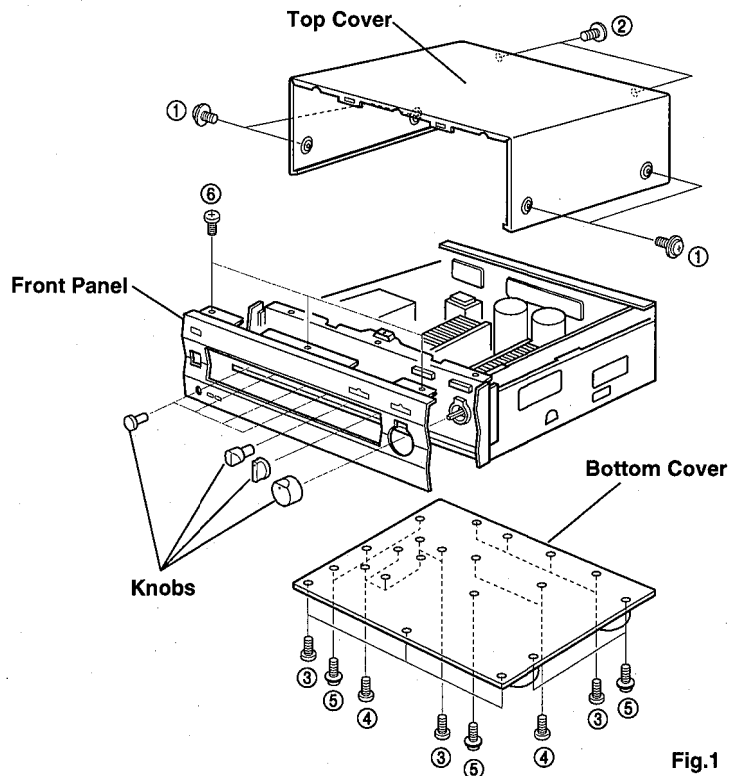

Fig.1

AX-892

AX-892 SPECIFICATIONS

AUDIO SECTION

Minimum RMS output Power per Channel		
20Hz to 20kHz, 0.015% THD, 8Ω	115W+115W	
20Hz to 20kHz, 0.03% THD, 6Ω	140W+140W	
Dynamic Power Per Channel(IHF)		
8/6/4/2Ω	150/200/250/330W	
DIN Standard Output Power Per Channel		
G model only		
1kHz, 0.7% THD, 4Ω	190W	
IEC Power		
G model only		
1kHz, 0.015% THD, 6Ω	125W	
Power Band Width		
0.03% THD, 57.5W, 8Ω	10Hz to 50kHz	
Damping Factor (SP-A)		
20Hz to 20kHz, 8Ω	320 or more	
Maximum Power (EIAJ)		
R model only		
1kHz, 10% THD, 8/6Ω	160/190W	
Input Sensitivity/Impedance		
PHONO MC	160μV/250Ω	
PHONO MM	2.5mV/47kΩ	
CD etc	150mV/47kΩ	
MAIN IN	1V/30kΩ	
Maximum input Signal Level		
PHONO MC, 1kHz, 0.007% THD	10mV	
PHONO MM, 1kHz, 0.007% THD	150mV	
Output Level/Impedance		
REC OUT	150mV/600Ω	
PRE OUT	1V/1.2kΩ	
Headphone Jack Rated Output/Impedance		
0.015% THD, RL=8Ω	0.35V/680Ω	
Frequency Response(20Hz to 20kHz)		
CD etc	0±0.5dB	
MAIN IN	0±0.5dB	
RIAA Equalization Deviation		
PHONO MC	0±0.5dB	
PHONO MM	0±0.3dB	
Total Harmonic Distortion(20Hz to 20kHz)		
PHONO MC to REC OUT (3V)	0.007%	
PHONO MM to REC OUT (3V)	0.003%	
CD etc to PRE OUT(1V)	0.005%	
CD etc to SP OUT(57.5W/8Ω)	0.008%	
Signal-to-Noise Ratio(IHF-A-Network)		
PHONO MC, (500μV Input Shorted)	76dB	
PHONO MM, (5mV Input Shorted)	92dB	
CD, CD DIRECT AMP ON (Shorted)	110dB	
Residual Noise(IHF-A-Network)		
CD DIRECT AMP ON	35μV	
PURE DIRECT ON	90μV	
Channel Separation(Vol. -30dB)		
CD etc(Input 5.1kΩ terminated), 1kHz/10kHz	65/50dB	
Tone Control Characteristics		
BASS : Boost/Cut	±10dB(20Hz)	
: Turnover Frequency	350Hz	
TREBLE : Boost/Cut	±10dB(20kHz)	
: Turnover Frequency	3.5kHz	
Filter Characteristics		
SUBSONIC FILTER	15Hz, -18dB/oct	

Continuous Loudness Control

Attenuation (Level related equalization)	-30dB(1kHz)
Gain Tracking Error(0~-60dB)	2dB
Audio Muting	-20dB

GENERAL

Power Supply	
R model	AC110/120/220/240V, 50/60Hz
G model	AC230V, 50Hz
Power Consumption	
	270W
AC Outlet	
	100W max
Dimensions (W x H x D)	
	435 x 171 x 396mm (17-1/8"x6-23/32"x15-19/32")
Weight	
	13kg(23lbs 6oz)
Accessories	
	Remote Control Transmitter x 1 Battery (size "AA", "R06") x 2

* Specifications subject to change without notice.

R General model
G European model

DIMENSIONS

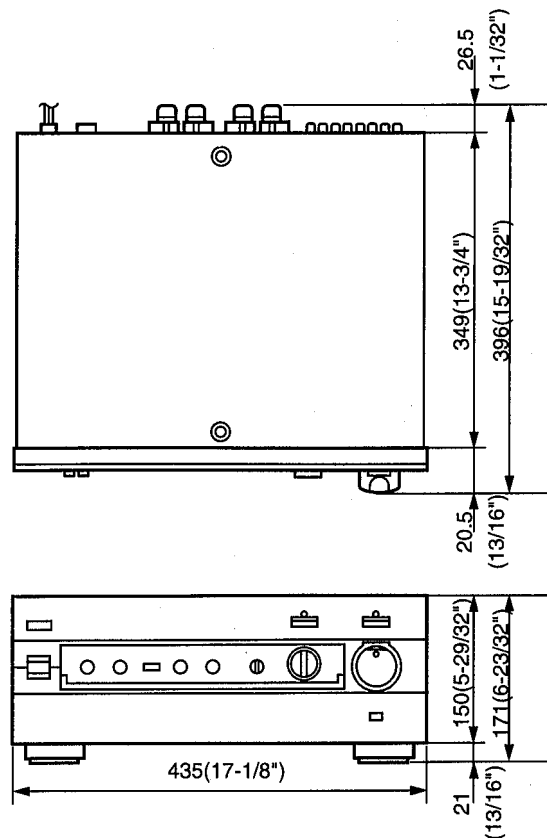

Units: mm (inch)

AX-892

AX-892 INTERNAL VIEW

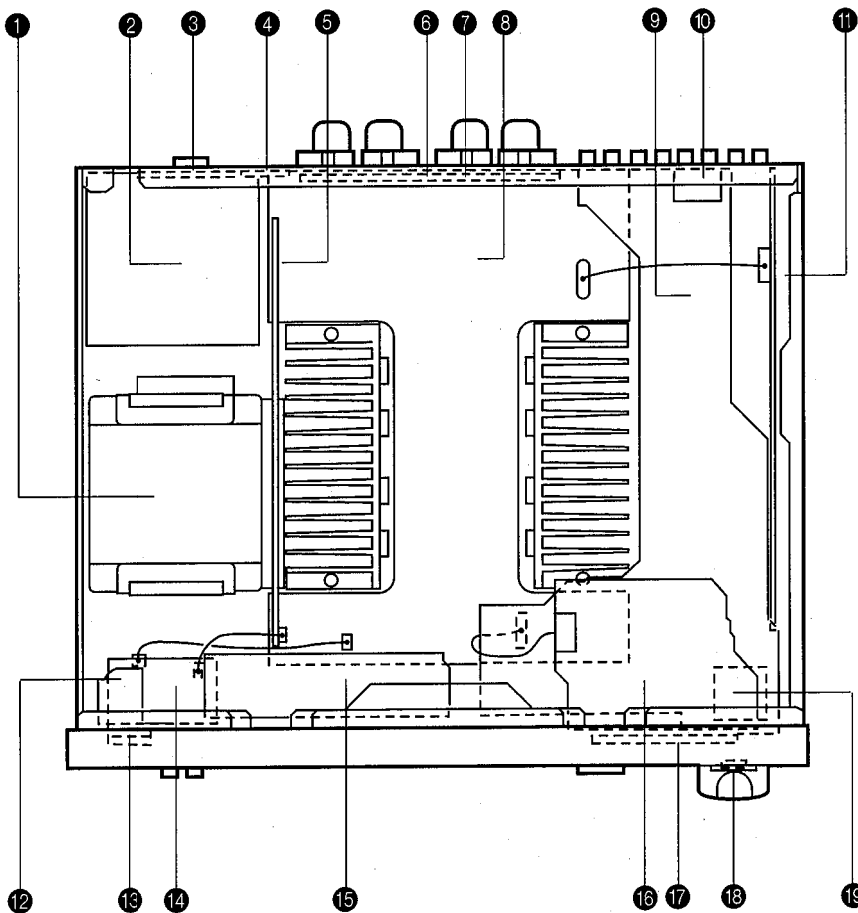

- ① POWER TRANSFORMER
- ② MAIN P.C.B. ASS'Y (2)
- ③ MAIN P.C.B. ASS'Y (4) (R model Only)
- ④ MAIN P.C.B. ASS'Y (3)
- ⑤ MAIN P.C.B. ASS'Y (7)
- ⑥ MAIN P.C.B. ASS'Y (5)
- ⑦ MAIN P.C.B. ASS'Y (6)
- ⑧ MAIN P.C.B. ASS'Y (1)
- ⑨ FUNCTION P.C.B. ASS'Y (2)
- ⑩ FUNCTION P.C.B. ASS'Y (10)
- ⑪ FUNCTION P.C.B. ASS'Y (1)
- ⑫ FUNCTION P.C.B. ASS'Y (9)
- ⑬ FUNCTION P.C.B. ASS'Y (5)
- ⑭ FUNCTION P.C.B. ASS'Y (8)
- ⑮ FUNCTION P.C.B. ASS'Y (4)
- ⑯ FUNCTION P.C.B. ASS'Y (3)
- ⑰ FUNCTION P.C.B. ASS'Y (6)
- ⑱ FUNCTION P.C.B. ASS'Y (7)
- ⑲ FUNCTION P.C.B. ASS'Y (11)

AX-892 DISASSEMBLY PROCEDURES

(Remove parts in disassembly order as numbered.)

1. Removal of Top Cover

- a. Remove 4 screws (①) in Fig. 1.
- b. Remove 2 screws (②) in Fig. 1.
- c. Remove 2 screws (③) in Fig. 1.

2. Removal of Bottom Cover

- a. Remove 9 screws (④) in Fig. 1.
- b. Remove 6 screws (⑤) in Fig. 1.
- c. Remove 6 screws (⑥) in Fig. 1.

3. Removal of Front Panel

- a. Remove 7 knobs in Fig. 1.
- b. Remove 3 screws (⑦) in Fig. 1.

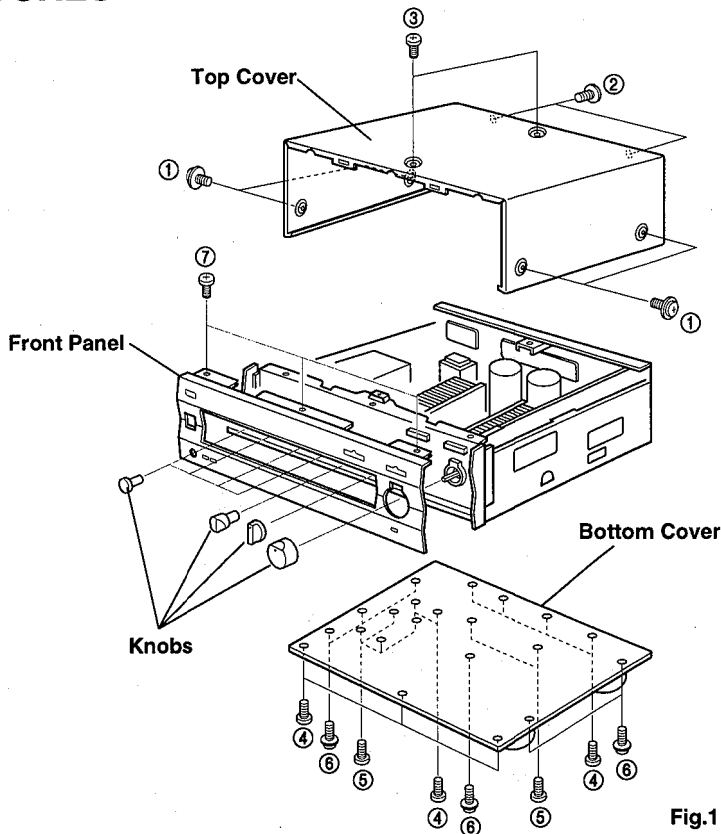

CAUTION FOR SERVICING - USE ONLY COPPER COLORED SCREWS (3x10 ø8) FOR POINTS INDICATED BY ARROWS (←).

Fig.1

AMP ADJUSTMENT

Confirmation of Idling Current

- Right after power is turned on, confirm that the voltage across the terminals of CB109 (Lch) and CB110 (Rch) are between 0.2mV~4.0mV.
- If it exceeds 4.1mV, open (cut off) R175 (on CB109), R176 (on CB110) and reconfirm the voltage.

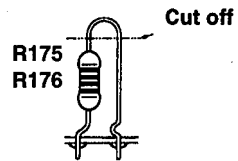
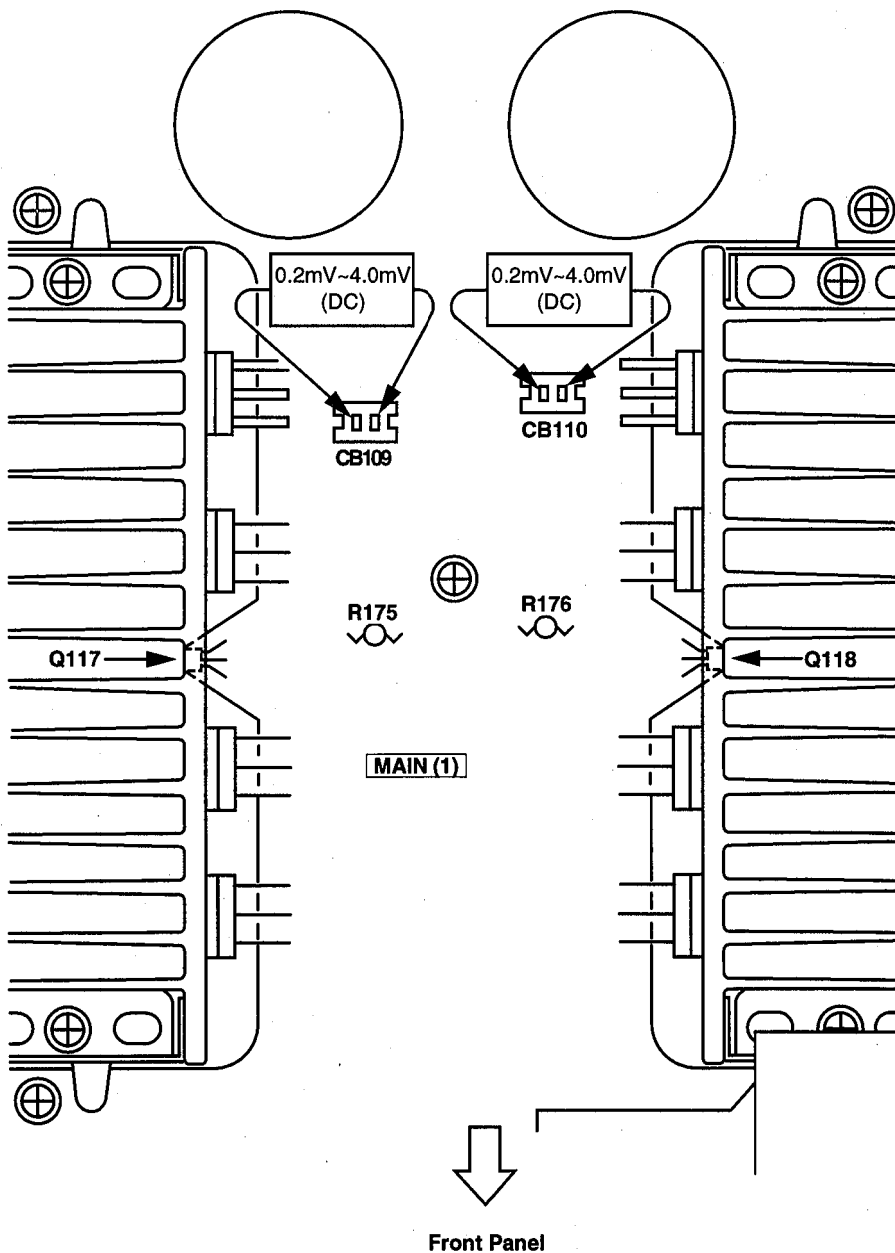

Note)

- If R175 and R176 have already been cut off and idling current does not flow, reconnect R175 and R176.
- Q117 and Q118 are transistors for temperature correction. Apply silicone grease to contact surface with the heat sink.
- **Removal of Power Transistor**
 - a. Use a 5.5mm wrench or a small size adjustable wrench.
 - b. Using the above tool, remove the screw holding the Power Transistor.

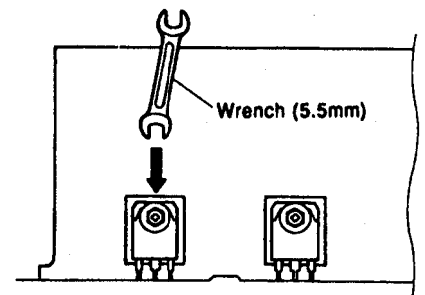

μ-COM DATA

IC309 : LC6520H-4J33

4bit μ-COM

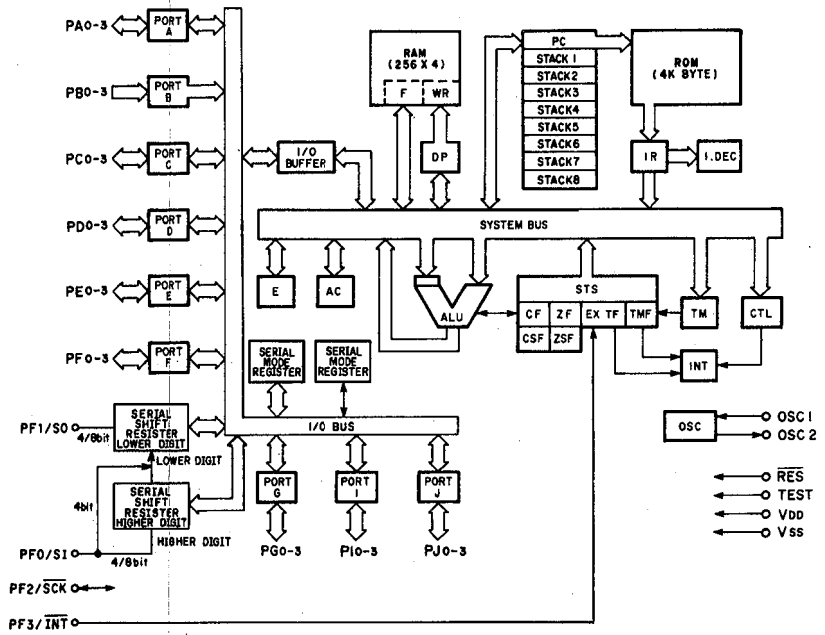
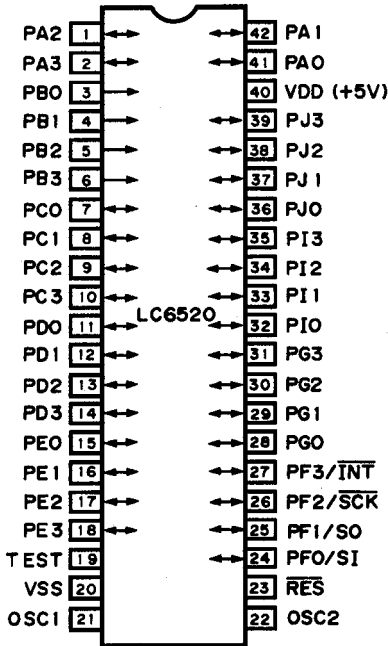

Table A
Selector Position Data(S1 to S8)

PIN No.										FUNCTION
3	4	5	6	7	8	9	10			
1	1	0	0	0	0	0	0	0	0	PHONO
0	1	1	0	0	0	0	0	0	0	TUNER
0	0	1	1	0	0	0	0	0	0	CD
0	0	0	1	1	0	0	0	0	0	TAPE1
0	0	0	0	1	1	0	0	0	0	TAPE2
0	0	0	0	0	1	1	0	0	0	AUX

No.	Port	I/O	Function	Logic
1	PA2		GND	
2	PA3		+5V	
3	PB0	I	Selector Position data (Table A)	S1
4	PB1	I		S2
5	PB2	I		S3
6	PB3	I		S4
7	PC0	I		S5 (L: RESET)
8	PC1	I		S6(L: RESET)
9	PC2	I		S7(L: RESET)
10	PC3	I		S8(L: RESET)
11	PDO	I	Cam position data	H: CAM(L: RESET)
12	PD1		GND	(L: RESET)
13	PD2		GND	(L: RESET)
14	PD3	O	PLAY / CUT (Player control)	H: ON(L: RESET)
15	PE0		GND	
16	PE1	I	Power down detect (BACK-UP mode)	L: PD
17	PE2		GND	
18	PE3		GND	
19	TEST		GND	
20	Vss		GND	
21	OSC1		4MHz	

No.	Port	I/O	Function	Logic
42	PA1		GND	
41	PA0		GND	
40	VDD		+5V	
39	PJ3	O	Muting control detect	H: ON
38	PJ2		OPEN	
37	PJ1		OPEN	
36	PJ0		GND	
35	PI3	O	Selector control signal	
34	PI2	O	Selector control signal	
33	PI1	O	Volume control signal	
32	PI0	O	Volume control signal	
31	PG3	O	Standby detect	H: ON
30	PG2	O	Power detect	H: ON
29	PG1	I	Power SW Type detect	H: LOCK
28	PG0	I	Power SW Key detect	H: SW ON
27	PF3	I	Remote Control data	
26	PF2	I	Protection detect	H: PRT
25	PF1		GND	
24	PF0		GND	
23	RES		RESET	L: RESET
22	OSC2		4MHz	

*When in the BACK-UP mode.(i.e., when the AC plug has been unplugged), the state before unplugging the AC plug (POWER ON/OFF) is kept in memory.

AX-592 SCHEMATIC DIAGRAM (FUNCTION) / 総回路図 (ファンクション)

IC307, 308 : TA7291S Motor Drive

IC BLOCK

IC301 : μPC4570HA Dual OP Amp

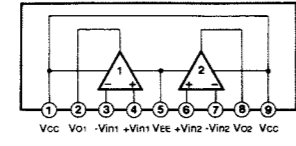

IC302 : NJM4558LD IC305,306 : NJM2068LD Dual OP Amp

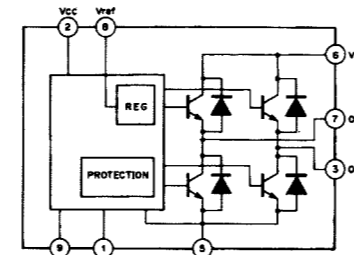
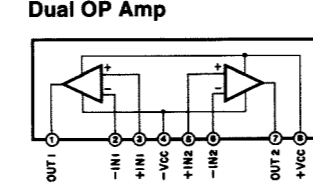

REMARKS	PARTS NAME
NO MARK	CARBON FILM RESISTOR (P-5)
△	CARBON FILM RESISTOR (P-10)
▲	METAL OXIDE FILM RESISTOR
■	METAL FILM RESISTOR
□	METAL PLATE RESISTOR
○	FIRE PROOF CARBON FILM RESISTOR
◇	CEMENT MOLDED RESISTOR
◎	SEM1 VARIABLE RESISTOR
●	CHIP RESISTOR

REMARKS	PARTS NAME
∞	ELECTROLYTIC CAPACITOR
∅	TANTALUM CAPACITOR
○	CERAMIC TUBULAR CAPACITOR
○	POLYESTER FILM CAPACITOR
○	POLYSTYRENE FILM CAPACITOR
○	MICA CAPACITOR
○	POLYPROPYLENE FILM CAPACITOR
●	SEMICONDUCTIVE CERAMIC CAPACITOR

Parts Number	Reference Parts Number	Parts Name
41		
42	D301-302-306-309-311-312-314-315-319	HSS104 HSS138 HSS176

TEST POINT WAVEFORMS / 波形ポイント

Point ① (Pin 22 of IC309) V: 2V/div H: 0.1μsec/div DC range 1:1 probe

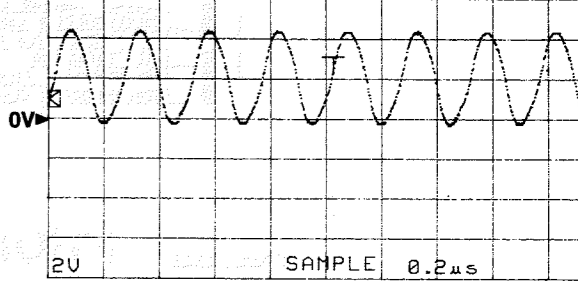

Point ② (CH1: Emitter of Q358 CH2: Pin 23 of IC309) V: 5V/div H: 0.5sec/div DC range 1:1 probe

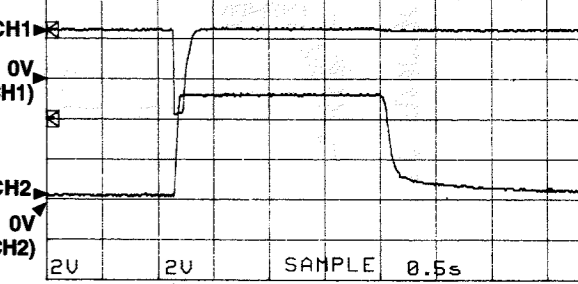

With the POWER switch turned ON, connect the power cord to the AC outlet. Disconnect the power cord from the AC outlet. (This waveform is not available by pushing the power switch ON and OFF.)

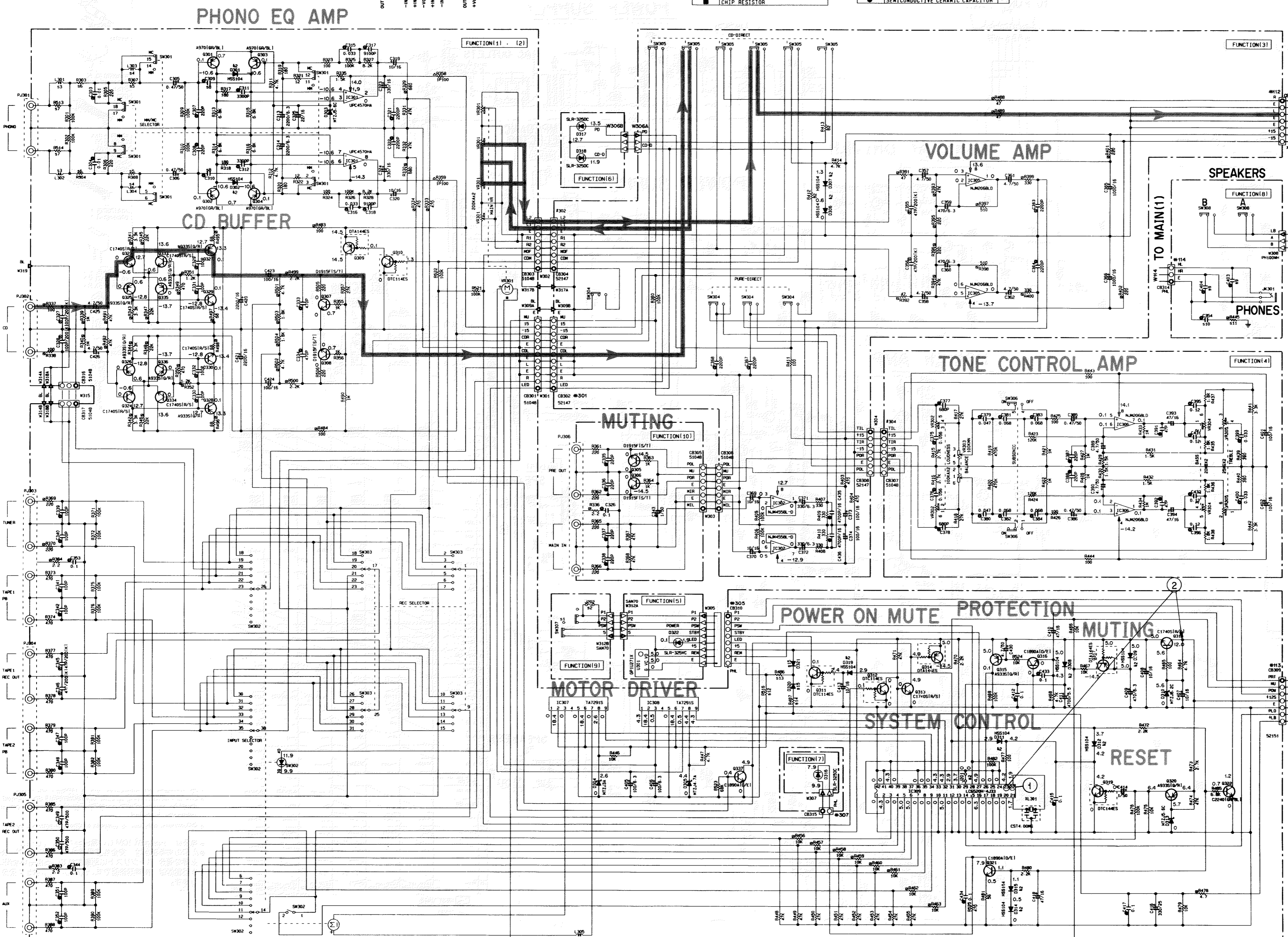

Pin	J-U-C	A.A.B.B.
1	SW307	VV49620
2	J201-202	
3	L301-302	200μF TP541101
4	L303-304	200μF TP659601
5	R307-308	27
6	R303-304	10
7	R513-514	10
8	C305-310	100P
9	C403-404	0.01
10	C254	0.01
11	R445	2.2
12	R515	2.2K
13	R466	800
14	R487	1.2K
15	D300-301	HSS104 HSS138 HSS176

PIN CONNECTION DIAGRAM OF TRANSISTORS, DIODES AND ICs.

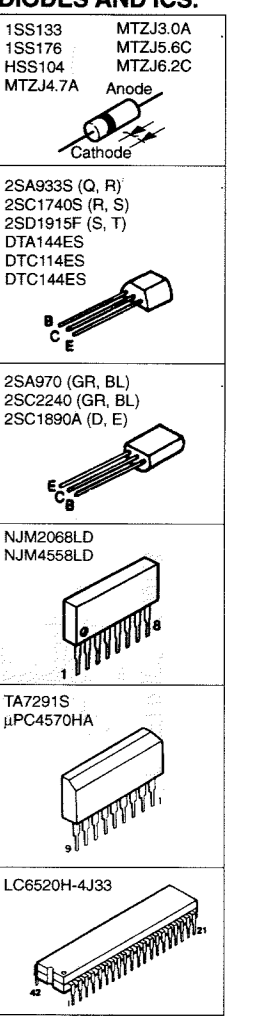

- Conditions/設定条件
- FUNCTION → CD
 - REC OUT → CD
 - SPEAKERS → A:ON B:OFF
 - VOLUME → minimum (-∞)

* All voltages are measured with a 10MΩ/V DC electric volt meter.
 * Components having special characteristics are marked △ and must be replaced with parts having specifications equal to those originally installed.
 * Schematic diagram is subject to change without notice.
 ●電圧は、内部抵抗 10MΩ の電圧計で測定したものです。
 ●△印のある部品は、安全性確保部分を示しています。部品の交換が必要な場合、パーツリストに記載されている部品を使用してください。
 ●本回路図は、標準回路図です。改良のため予告なく変更することがあります。

AX-892 SCHEMATIC DIAGRAM (MAIN) / 総回路図 (メイン)

REMARKS	PARTS NAME	MARK
NO MARK	ELECTROLYTIC CAPACITOR	△
NO MARK	TANTALUM CAPACITOR	△
NO MARK	CERAMIC CAPACITOR	○
●	CERAMIC TUBULAR CAPACITOR	
○	POLYESTER FILM CAPACITOR	
○	POLYSTYRENE FILM CAPACITOR	
○	MICA CAPACITOR	
○	POLYPROPYLENE FILM CAPACITOR	
●	SEMICONDUCTIVE CERAMIC CAPACITOR	

REMARKS	PARTS NAME	MARK
NO MARK	CARBON FILM RESISTOR (P-5)	△
△	CARBON FILM RESISTOR (P-10)	
△	METAL OXIDE FILM RESISTOR	
△	METAL FILM RESISTOR	
△	METAL PLATE RESISTOR	
△	FIRE PROOF CARBON FILM RESISTOR	
△	CEMENT MOLDED RESISTOR	
△	SEMI VARIABLE RESISTOR	
■	CHIP RESISTOR	

NOTICE (mode1)
 (J)..... JAPANESE
 (U)..... U. S. A
 (C)..... CANADIAN
 (R)..... GENERAL
 (A)..... AUSTRALIAN
 (B)..... BRITISH
 (G)..... EUROPEAN
 (T)..... CHINA
 (L)..... SINGAPORE

Mark	Reference Parts Number	Parts Name
41	0101-106-109-115-123	MS104
		155133
		155176
42		
43		

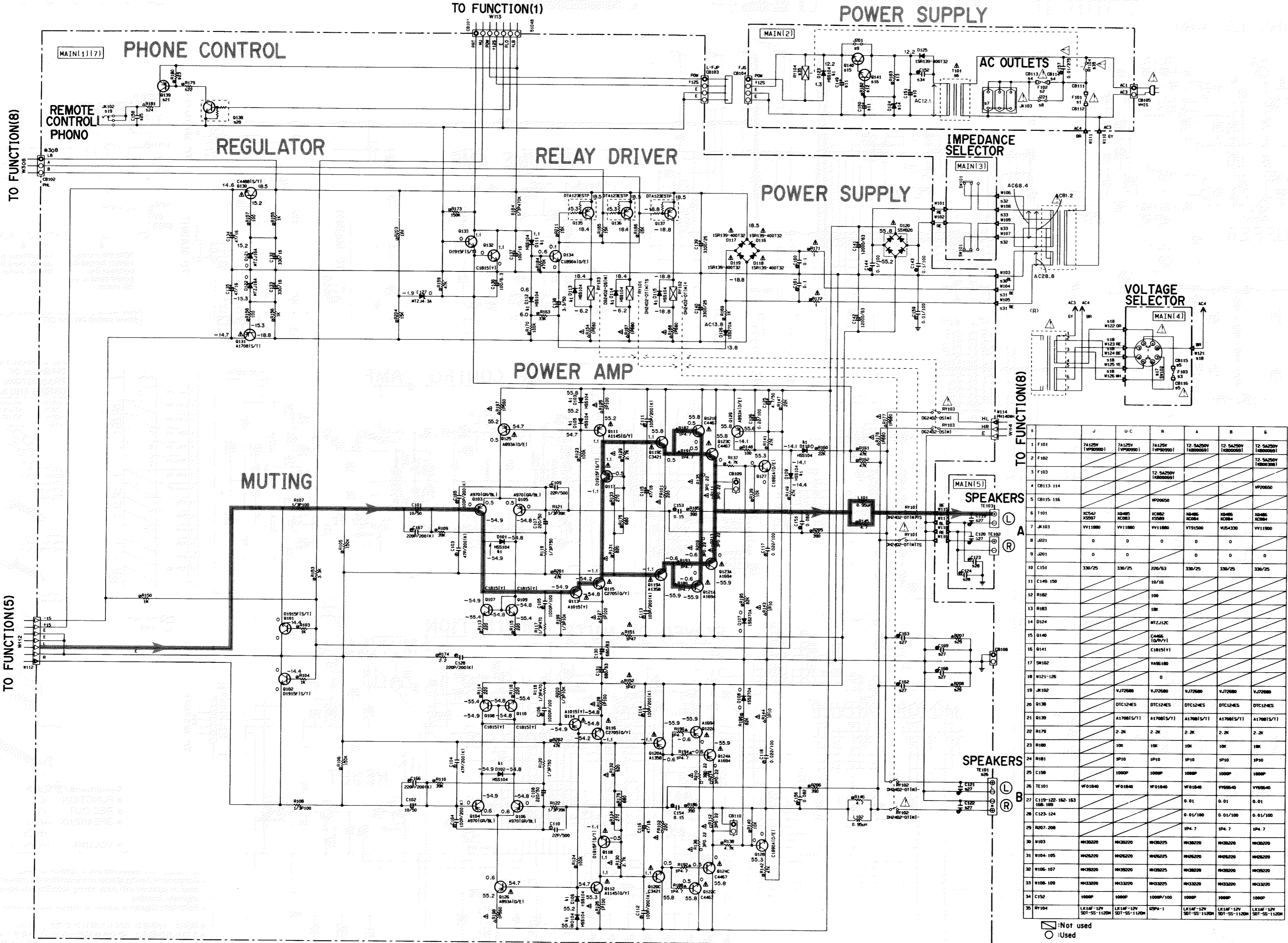

PIN CONNECTION DIAGRAM OF TRANSISTORS, DIODES AND ICs.

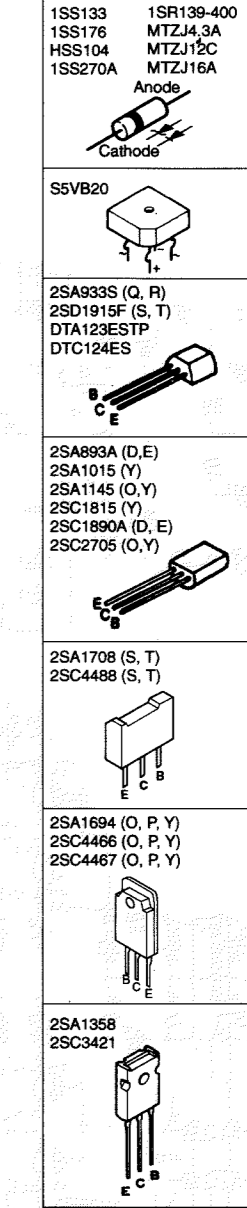

	J	U	C	R	A	B	G
1 F101	7A120V (VPC020)	7A120V (VPC020)	7A120V (VPC020)	T2 5A250V (H000051)	T2 5A250V (H000051)	T2 5A250V (H000391)	
2 F102							
3 F103				T2 5A250V (H000051)			
4 CB113-114				VP0650			VP0650
5 CB115-116							
6 F101	K2542 (X597)	30485 (X083)	K2082 (X589)	W4485 (X084)	30486 (X084)	30486 (X084)	30486 (X084)
7 JK103	VV11880	VV11880	VV11880	VV11880	VV11880	VV11880	VV11880
8 J021	0	0	0	0	0	0	0
9 J001	0	0	0	0	0	0	0
10 C151	330/25	330/25	220/63	330/25	330/25	330/25	330/25
11 C149-150			10/16				
12 R182			100				
13 R183			10K				
14 D124			MTZJ12C				
15 Q140			C4466 (O, P, Y)				
16 Q141			C1815 (Y)				
17 D102			VA06180				
18 W121-126			0				
19 JK102		VJ72680	VJ72680	VJ72680	VJ72680	VJ72680	VJ72680
20 Q138		DTC124ES	DTC124ES	DTC124ES	DTC124ES	DTC124ES	DTC124ES
21 Q139		A17081S/T	A17081S/T	A17081S/T	A17081S/T	A17081S/T	A17081S/T
22 R178		2.2K	2.2K	2.2K	2.2K	2.2K	2.2K
23 R180		10K	10K	10K	10K	10K	10K
24 R181		SP10	SP10	SP10	SP10	SP10	SP10
25 C158		1000P	1000P	1000P	1000P	1000P	1000P
26 TE101	VF01840	VF01840	VF01840	VF01840	VF06640	VF06640	VF06640
27 C119-122-152-153-158-169				0.01	0.01	0.01/100	0.01/100
28 C123-124				0.01/100	0.01/100	0.01/100	0.01/100
29 R007-208				10K	10K	10K	10K
30 R103	HC3020	HC3020	HC3020	HC3020	HC3020	HC3020	HC3020
31 R104-105	HC06200	HC06200	HC06200	HC06200	HC06200	HC06200	HC06200
32 R106-107	HC30200	HC30200	HC30200	HC30200	HC30200	HC30200	HC30200
33 R108-109	HC33200	HC33200	HC33200	HC33200	HC33200	HC33200	HC33200
34 C152	1000P	1000P	1000P/100	1000P	1000P	1000P	1000P
35 RY104	LK14F-12V (S1-SS-1120)	LK14F-12V (S1-SS-1120)	CSA-1	LK14F-12V (S1-SS-1120)	LK14F-12V (S1-SS-1120)	LK14F-12V (S1-SS-1120)	LK14F-12V (S1-SS-1120)

* All voltages are measured with a 10MΩ/V DC electric volt meter.
 * Components having special characteristics are marked △ and must be replaced with parts having specifications equal to those originally installed.
 * Schematic diagram is subject to change without notice.

● 電圧は、内部抵抗 10MΩ の電圧計で測定したものです。
 ● △印のある部品は、安全性確保部分を示しています。部品の交換が必要な場合、パーツリストに記載されている部品を使用してください。
 ● 本回路図は、標準回路図です。改良のため予告なく変更することがあります。

□: Not used
 ○: Used

AX-892 SCHEMATIC DIAGRAM (FUNCTION) / 総回路図 (ファンクション)

IC307, 308 : TA7291S Motor Drive

AX-892

IC BLOCK IC301 : μPC4570HA Dual OP Amp

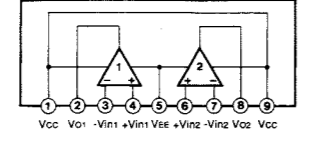

IC302 : NJM4558LD IC305,306 : NJM2068LD Dual OP Amp

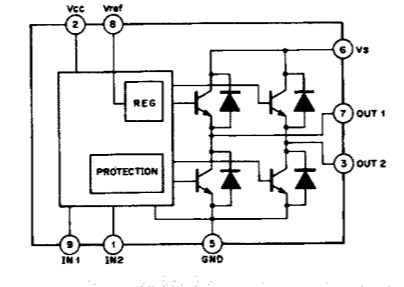
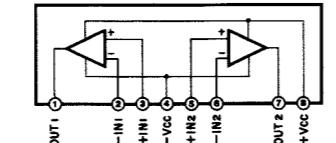

Table with 2 columns: REMARKS and PARTS NAME. Lists various resistor types such as Carbon Film Resistor, Metal Oxide Film Resistor, Metal Plate Resistor, Fire Proof Carbon Film Resistor, Cement Molded Resistor, Semi Variable Resistor, and Chip Resistor.

Table with 2 columns: REMARKS and PARTS NAME. Lists various capacitor types such as Electrolytic Capacitor, Tantalum Capacitor, Ceramic Capacitor, Ceramic Tubular Capacitor, Polyester Film Capacitor, Polyethylene Film Capacitor, Mica Capacitor, Polypropylene Film Capacitor, and Semiconductive Ceramic Capacitor.

Table with 3 columns: Mark, Reference Parts Number, and Parts Name. Lists interchangeable parts for manufacture stage, including reference numbers like 0301, 302, 306-309, 311, 312, 314, 315, 319 and parts names like HSS104, HSS133, HSS176.

TEST POINT WAVEFORMS / 波形ポイント

Point ① (Pin 22 of IC309) V : 2V/div H : 0.1μsec/div DC range 1 : 1 probe

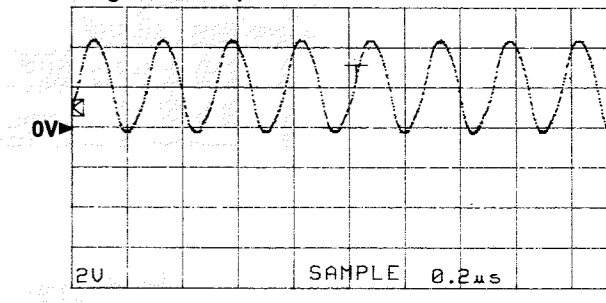

Point ② (CH1 : Emitter of Q358 CH2 : Pin 23 of IC309) V : 5V/div H : 0.5sec/div DC range 1 : 1 probe

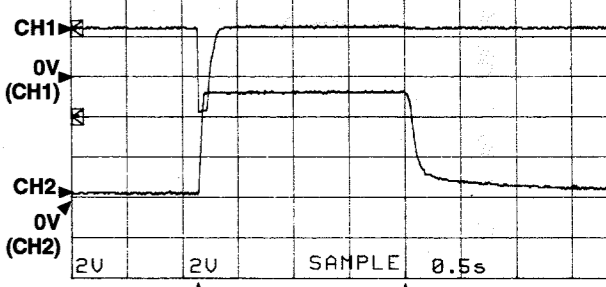

With the POWER switch turned ON, connect the power cord to the AC outlet. Disconnect the power cord from the AC outlet.

(This waveform is not available by pushing the power switch ON and OFF.)

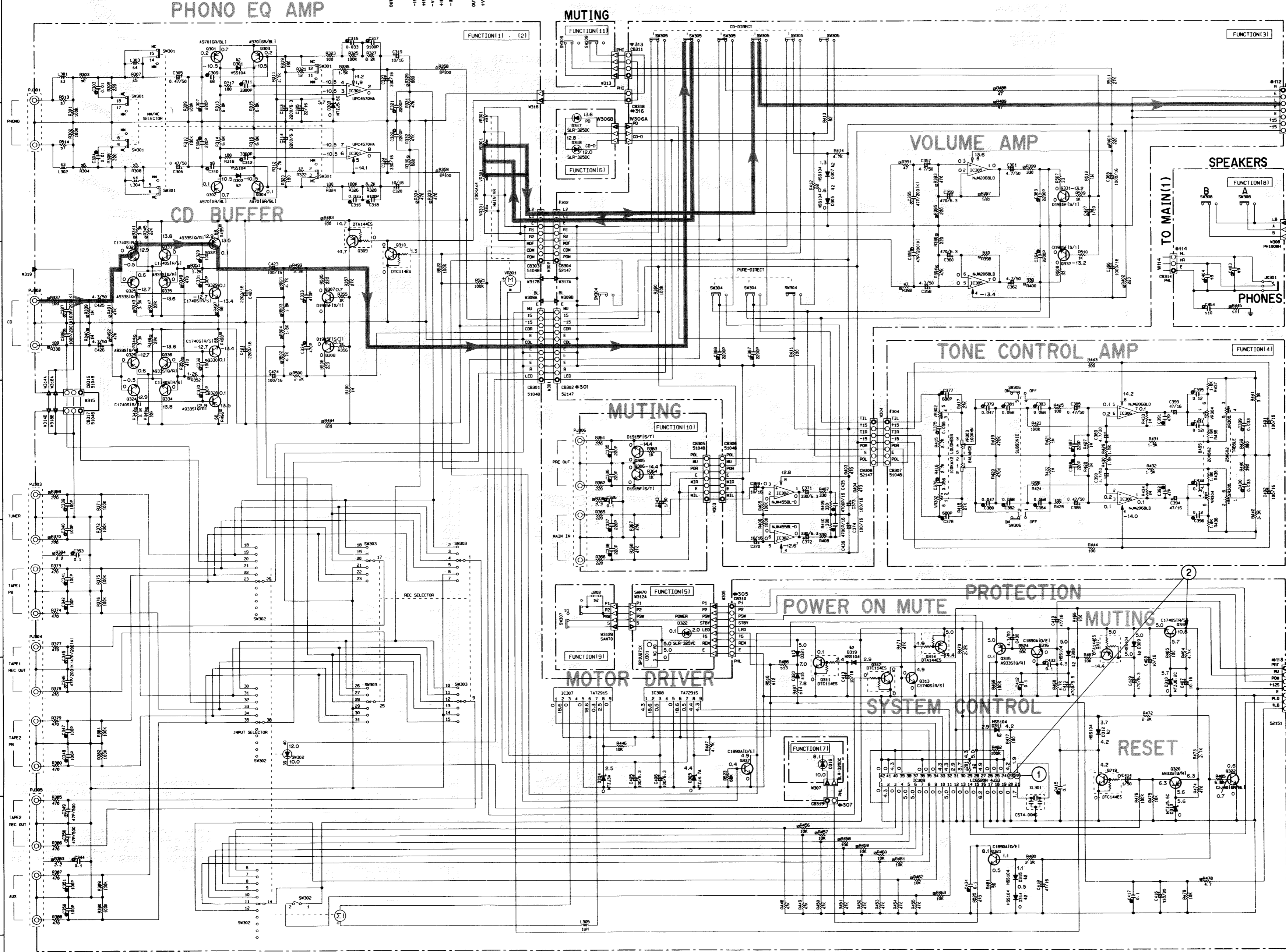
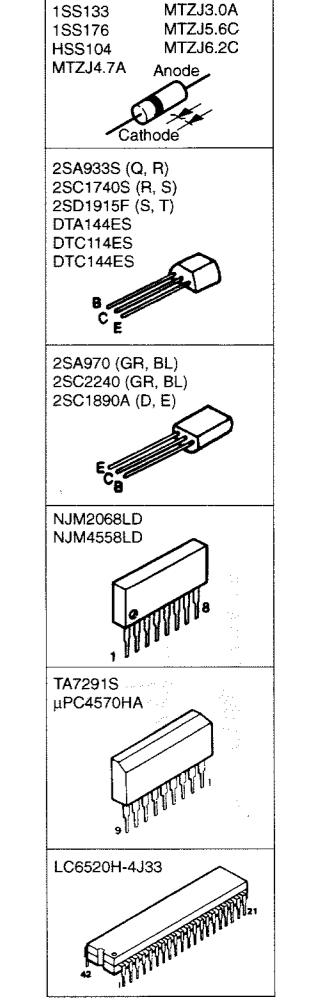

Table with 3 columns: Pin, Part Name, and Value. Lists pin connections for various components like SW307, J201-202, L301-302, L303-304, R307-308, R303-304, R313-314, C309-310, C403-404, C354, R445, R456, R466, R467, and D300-321.

PIN CONNECTION DIAGRAM OF TRANSISTORS, DIODES AND ICs.



□ : Not used ○ : Used

- Conditions / 設定条件
● FUNCTION → CD
● REC OUT → CD
● SPEAKERS → A:ON, B:OFF
● VOLUME → minimum (-∞)

All voltages are measured with a 10MΩ/2V DC electric volt meter. Components having special characteristics are marked Δ and must be replaced with parts having specifications equal to those originally installed. Schematic diagram is subject to change without notice.

電圧は、内部抵抗 10MΩ の電圧計で測定したものです。△印のある部品は、安全性確保部分を示しています。部品の交換が必要な場合、パーツリストに記載されている部品を使用してください。本回路図は、標準回路図です。改良のため予告なく変更することがあります。

AX-592 SCHEMATIC DIAGRAM (MAIN) / 総回路図 (メイン)

CAPACITOR

REMARKS	PARTS NAME	MARK
NO MARK	ELECTROLYTIC CAPACITOR	ES
◎	TANTALUM CAPACITOR	
NO MARK	CERAMIC CAPACITOR	
◎	CERAMIC TUBULAR CAPACITOR	
◎	POLYESTER FILM CAPACITOR	
◎	POLYSTYRENE FILM CAPACITOR	
◎	MICA CAPACITOR	
◎	POLYPROPYLENE FILM CAPACITOR	
◎	SEMICONDUCTIVE CERAMIC CAPACITOR	

RESISTOR

REMARKS	PARTS NAME	MARK
NO MARK	CARBON FILM RESISTOR (P=5)	
◎	CARBON FILM RESISTOR (P=10)	
△	METAL OXIDE FILM RESISTOR	
◎	METAL FILM RESISTOR	
◎	METAL PLATE RESISTOR	
◎	FIRE PROOF CARBON FILM RESISTOR	
◎	CEMENT MOLDED RESISTOR	
◎	SEMI VARIABLE RESISTOR	
◎	CHIP RESISTOR	

NOTICE (mode1)
 (J)..... JAPANESE
 (U)..... U. S. A
 (C)..... CANADIAN
 (R)..... GENERAL
 (A)..... AUSTRALIAN
 (B)..... BRITISH
 (G)..... EUROPEAN
 (T)..... CHINA
 (L)..... SINGAPORE

Interchangeable Parts at Manufacture Stage

Mark	Reference Parts Number	Parts Name
△1	D101-106-109-115-123	HSS104
		15S133
		15S176

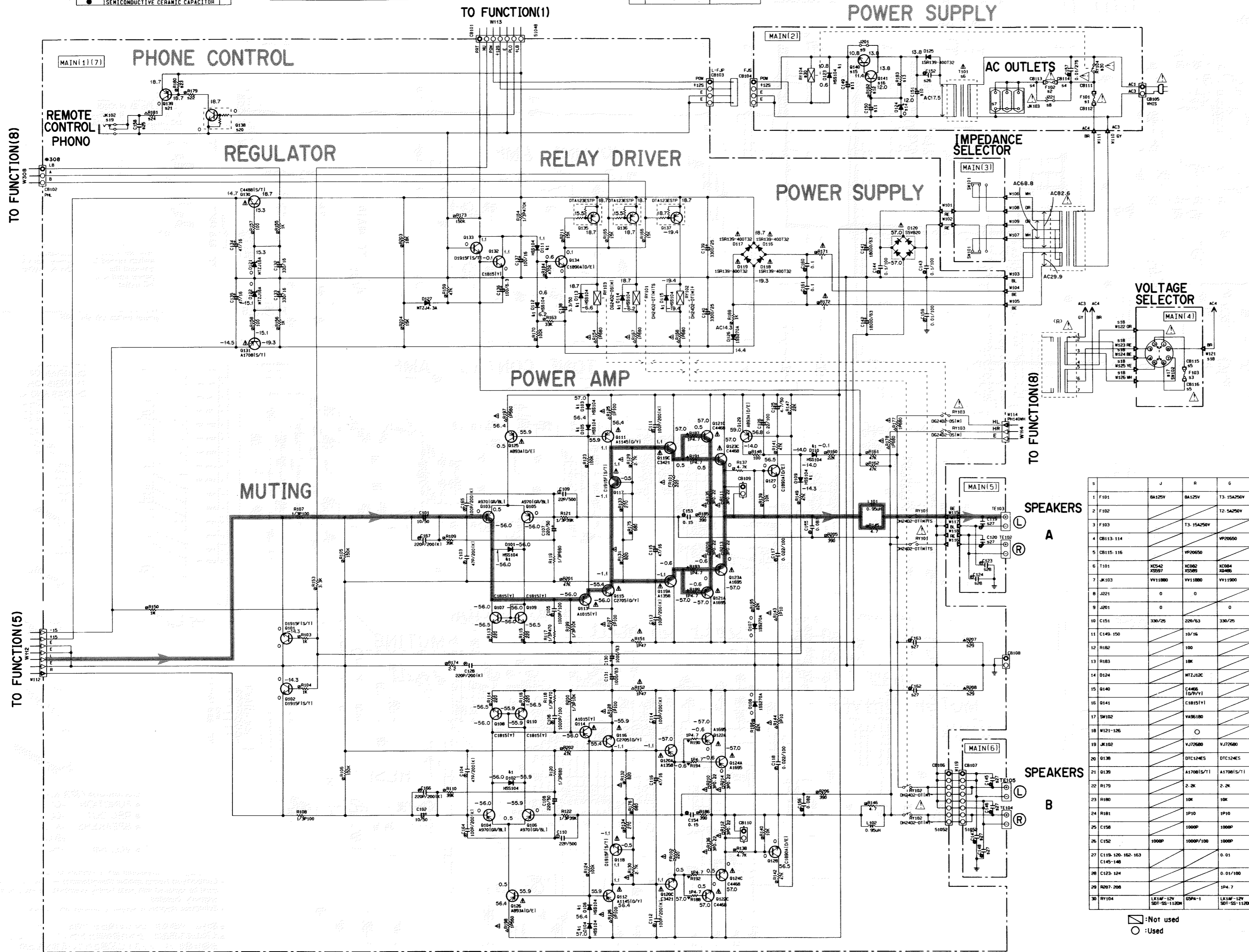

PIN CONNECTION DIAGRAM OF TRANSISTORS, DIODES AND ICs.

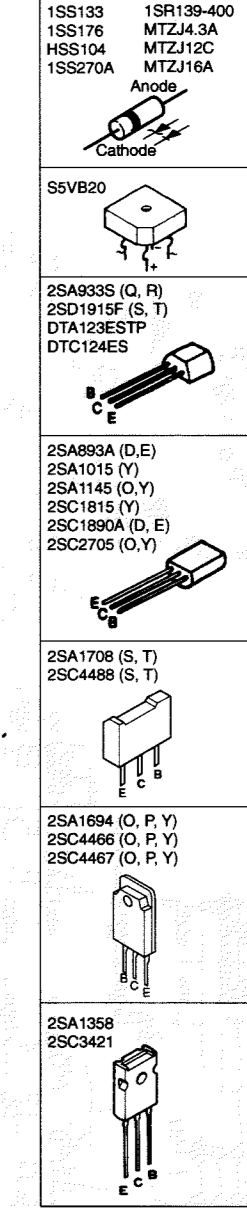

	J	R	G
1 F101	8A25V	8A125V	T3 15A250V
2 F102			T2 5A250V
3 F103			T3 15A250V
4 CB113-114			VP20650
5 CB115-116		VP20650	
6 T101	K2542	K2582	K2084
	K2597	K2682	K2486
7 J103	VY11880	VY11880	VY11900
8 J201	0	0	0
9 J201	0	0	0
10 C151	330/25	200/63	330/25
11 C149-150		10/16	
12 R182		100	
13 R183		10K	
14 D124		MTZJ12C	
15 D140		C4466	(D/P/Y)
16 D141		C18151Y1	
17 SH102		V436180	
18 W121-126		0	
19 J102		VJ72680	VJ72680
20 D138		DTC124ES	DTC124ES
21 D139		A17081S/71	A17081S/71
22 R179		2.2K	2.2K
23 R180		10K	10K
24 R181		1P10	1P10
25 C158		1000P	1000P
26 C152	1000P	1000P/100	1000P
27 C118-120-162-163			0.01
			C145-149
28 C123-124			0.01/100
29 R207-208			1P4.7
30 RY104	LX14F-12V	CS94-1	LX14F-12V
	SD1-5S-1120M		SD1-5S-1120M

* All voltages are measured with a 10MΩ/V DC electric volt meter.
 * Components having special characteristics are marked △ and must be replaced with parts having specifications equal to those originally installed.
 * Schematic diagram is subject to change without notice.

●電圧は、内部抵抗 10MΩの電圧計で測定したものです。
 ●△印のある部品は、安全性確保部分を示しています。部品の交換が必要な場合、パーツリストに記載されている部品を使用してください。
 ●本回路図は、標準回路図です。改良のため予告なく変更することがあります。

□: Not used
 ○: Used

SANYO

No. 2076D

LC6520C, 6522C, LC6520H, 6522H

Single-Chip 4-Bit Microcomputers for
Medium/Large-Scale Control-Oriented Applications

The LC6520C/H are single-chip 4-bit microcomputers that contain a 4K-byte ROM, 1K-bit RAM, have 42 pins, and are fabricated using CMOS process technology. Besides 8 input/output common ports of 32 pins and an input port of 4 pins, the LC6520C/H have specific ports that are used to provide the interrupt function, 4-bit/8-bit serial input/output function, and burst pulse output function. All output ports are of the open drain type with a withstand voltage of 15 V and a drive current of 20 mA and have the option of containing a pull-up resistance bitwise.

The LC6520C/H are the same as our LC6500 series in the basic architecture of the CPU and the instruction set, but are made more powerful in the stack level and the cycle time.

The LC6522C/H are the same as the LC6520C/H, except that they contain a 2k-byte ROM, 512-bit RAM.

Features

- Instruction set with 80 instructions (Common to the LC6500 series)
- ROM/RAM
 - : 4096 bytes/1024 bits (LC6520C/H)
 - : 2048 bytes/512 bits (LC6522C/H)
- Instruction cycle time: 6 μ s (C version, $V_{DD} = 3$ to 5.5V)
2.77 μ s (C version, $V_{DD} = 4$ to 5.5V)
9.92 μ s (H version, $V_{DD} = 4.5$ to 5.5V)
- Serial input/output interface x 1 (4 bits/8 bits program-selectable)
- I/O ports
 - Input port: 4 pins
 - Input/output common ports: 32 pins
 - Input/output withstand voltage: 15 V max (all input/output ports)
 - Output current: 20 mA max (all output ports)
 - Pull-up resistance: May be contained bitwise by option. (All output ports)
 - Output level during reset: For ports C, D, output (H or L) during reset may be specified portwise by option.

Package Dimensions 3025B-D42SIC
(unit: mm)

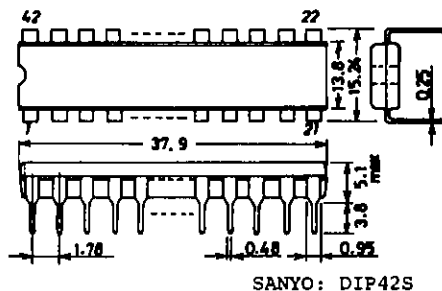

Package Dimensions 3052A-Q48AIC
(unit: mm)

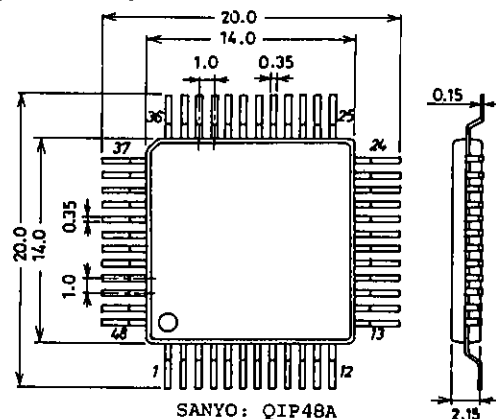

- Interrupt function
 Timer interrupt: 1
 $\overline{\text{INT}}$ pin or serial I/O interrupt: 1
- Stack level: 8 levels (common with interrupt)
- Timer: 4-bit prescaler + 8-bit programmable timer
- Burst pulse (64 x cycle time, duty 50%) output function
- Oscillator option
 Circuit mode: Ceramic mode, RC mode, external clock mode (200 kHz to 4.2 MHz)
 (Xtal OSC constants are being checked.)
 Predivider option: 1/1, 1/3, 1/4
- Standby function: Standby function provided by the HALT instruction
- Supply Voltage: 3 to 5.5 V (C version)
 4.5 to 5.5 V (H version)
- Package: DIP42 shrink type, QIP48

Pin Assignment

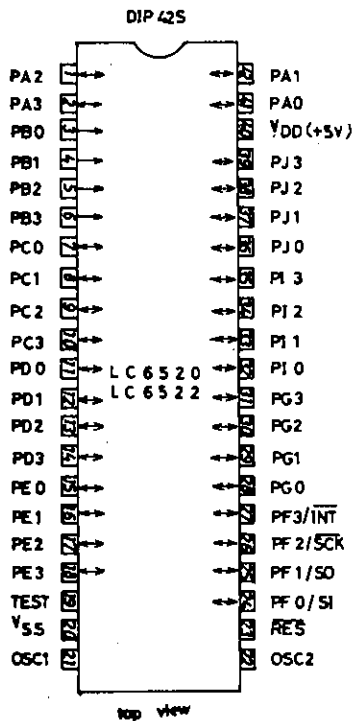

QIP48

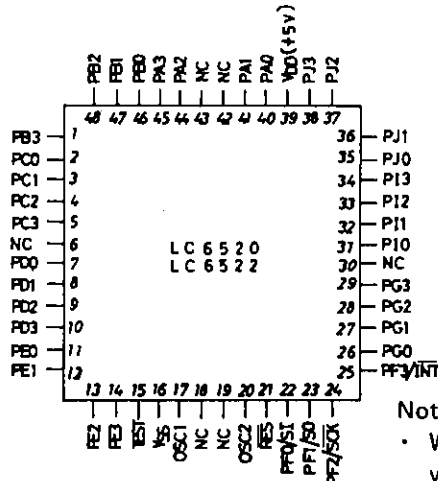

Note)

- When mounting the QIP version on the board, do not dip it in solder.
- Nothing must be connected to NC pin.

Pin Name

- OSC1, OSC2: RC, ceramic resonator, or X'tal for OSC
- $\overline{\text{INT}}$: Interrupt
- RES: Reset
- PA0-3: Input/output common port
- PB0-3: Input port
- PC0-3: Input/output common port
- PD0-3: Input/output common port
- PE0-3: Input/output common port
- PF0-3: Input/output common port
- PG0-3: Input/output common port
- PI0-3: Input/output common port
- PJ0-3: Input/output common port
- SCK: Serial Input/output port
- SO: Serial Input/output port
- SI: Serial Input/output port
- TEST: Test

Pin Description

Pin Name	Pins	I/O	Functions	Options	During Reset
V _{DD} V _{SS}	1 1		Power supply		
OSC1	1	Input	<ul style="list-style-type: none"> Pin for externally connecting R, C or a ceramic resonator for system clock generation For the external clock mode, the OSC2 pin is open. 	(1) External clock input (2) 2-pin RC OSC (3) 2-pin ceramic resonator OSC (4) Predivider option 1. No. predivider 2. 1/3 predivider 3. 1/4 predivider	
OSC2	1	Output			
PA ₀ PA ₁ PA ₂ PA ₃	4	Input/output	<ul style="list-style-type: none"> Input/output common port A₀ to 3. 4-bit input (IP instruction) 4-bit output (OP instruction) Single-bit decision (BP, BNP instructions) Single-bit set/reset (SPB, RPB instructions) Standby is controlled by the PA₃ (or PA₀ to 3). The PA₃ (or PA₀ to 3) pin must be free from chattering during the HALT instruction execution cycle. 	(1) Open drain type output (2) With pull-up resistance (1), (2): Specified bit by bit.	<ul style="list-style-type: none"> "H" output (Output Nch transistor OFF)
PB ₀ PB ₁ PB ₂ PB ₃	4	Input	<ul style="list-style-type: none"> Input Port B₀ to 3 4-bit input (IP instruction) Single-bit decision (BP, BNP instructions) 		
PC ₀ PC ₁ PC ₂ PC ₃	4	Input/output	<ul style="list-style-type: none"> Input/output common port C₀ to 3. The functions are the same as for the PA₀ to 3. (Note) Output ("H" or "L") during reset may be specified by option. <p>(Note) No standby control function is provided.</p>	(1) Open drain type output (2) With pull-up resistance (3) Output during reset: "H" (4) Output during reset: "L" <ul style="list-style-type: none"> (1), (2): Specified bit by bit. (3), (4): Specified in a group of 4 bits. 	<ul style="list-style-type: none"> "H" output "L" output (Option-selectable)
PD ₀ PD ₁ PD ₂ PD ₃	4	Input/output	<ul style="list-style-type: none"> Input/output common port D₀ to 3 The functions, options are the same as for the PC₀ to 3. 	Same as for the PC ₀ to 3.	Same as for the PC ₀ to 3.
PE ₀ PE ₁ PE ₂ PE ₃	4	Input/output	<ul style="list-style-type: none"> Input/output common port E₀ to 3 4-bit input (IP instruction) 4-bit output (OP instruction) Single-bit decision (BP, BNP instructions) Single-bit set/reset (SPB, RPB instructions) PE₀: With burst pulse (64T_{cyc}) output function 	(1) Open drain type output (2) With pull-up resistance (1), (2): Specified bit by bit.	<ul style="list-style-type: none"> "H" output (Output Nch transistor OFF)

Continued on next page.

Continued from preceding page.

Pin Name	Pins	I/O	Functions	Options	During Reset
PF ₀ /SI PF ₁ /SO PF ₂ / $\overline{\text{SCK}}$ PF ₃ / $\overline{\text{INT}}$	4	Input/output	<ul style="list-style-type: none"> Input/output port F₀ to 3 The functions, options are the same as for the PE₀ to 3. However, no burst pulse output function is provided. PF₀ to 3: Also used for serial interface, INT input. Program-selectable. 4 bits/8 bits of serial input/output: Program-selectable SI: Serial input port SO: Serial output port $\overline{\text{SCK}}$: Serial clock input/output INT: Interrupt request input 	Same as for the PE ₀ to 3.	Same as for the PE ₀ to 3. Serial port: Disable Interrupt source: $\overline{\text{INT}}$
PG ₀ PG ₁ PG ₂ PG ₃	4	Input/output	<ul style="list-style-type: none"> Input/output common port G₀ to 3 The functions, options are the same as for the PE₀ to 3. However, no burst pulse output function is provided. 	Same as for the PE ₀ to 3.	Same as for the PE ₀ to 3.
PI ₀ PI ₁ PI ₂ PI ₃	4	Input/output	<ul style="list-style-type: none"> Input/output common port I₀ to 3 The functions, options are the same as for the PG₀ to 3. 	Same as for the PG ₀ to 3.	Same as for the PG ₀ to 3.
PJ ₀ PJ ₁ PJ ₂ PJ ₃	4	Input/output	<ul style="list-style-type: none"> Input/output common port J₀ to 3 The functions, options are the same as for the PG₀ to 3. 	Same as for the PG ₀ to 3.	Same as for the PG ₀ to 3.
$\overline{\text{RES}}$	1	Input	<ul style="list-style-type: none"> System reset input For power-up reset, C is connected externally. For reset start, "L" level is applied for 4 clock cycles or more. 		
TEST	1	Input	<ul style="list-style-type: none"> LSI test pin Normally connected to V_{SS} 		

System Block Diagram

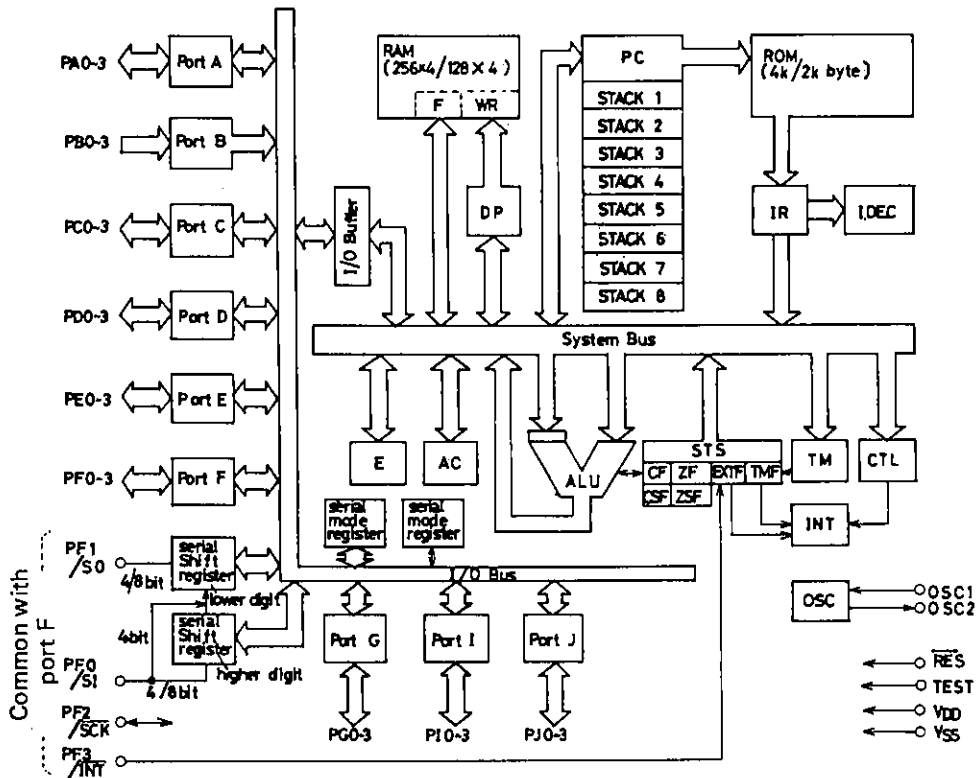

- | | | | |
|------|---------------------------|----------|---------------------------------|
| RAM: | Data memory | ROM: | Program memory |
| F: | Flag | PC: | Program counter |
| WR: | Working register | INT: | Interrupt control |
| AC: | Accumulator | IR: | Instruction register |
| ALU: | Arithmetic and logic unit | I.DEC: | Instruction decoder |
| DP: | Data pointer | CF, CSF: | Carry flag, carry save flag |
| E: | E register | ZF, ZSF: | Zero flag, zero save flag |
| CTL: | Control register | EXTF: | External interrupt request flag |
| OSC: | Oscillator | TMF: | Internal interrupt request flag |
| TM: | Timer | | |
| STS: | Status register | | |

Oscillator Circuit Option

Option Name	Circuit	Conditions, etc.
1. External Clock		<ul style="list-style-type: none"> Input: Schmitt type
2. 2-pin RC OSC		<ul style="list-style-type: none"> Input: Schmitt type
3. Ceramic Resonator OSC		

• Predivider Option

Option Name	Circuit	Conditions, etc.
1. No predivider		<ul style="list-style-type: none"> Applicable to all of 3 OSC options. The OSC frequency, external clock do not exceed 1444 kHz. (LC6520C, LC6522C) The OSC frequency, external clock do not exceed 4330 kHz. (LC6520H, LC6522H) Refer to Table of OSC, Predivider Option (Table 2).
2. 1/3 predivider		<ul style="list-style-type: none"> Applicable to only 2 options of external clock, ceramic resonator OSC. The OSC frequency, external clock do not exceed 4330 kHz. Refer to Table of OSC, Predivider Option (Table-2).
3. 1/4 predivider		<ul style="list-style-type: none"> Applicable to only 2 options of external clock, ceramic resonator OSC. The OSC frequency, external clock do not exceed 4330 kHz. Refer to table of OSC, Predivider Option (Table 2).

Options of Ports C, D Output Level during Reset

For input/output common ports C, D, either of the following two output levels may be selected in a group of 4 bits during reset by option.

Option Name	Conditions, etc.
1. Output during reset: "H" level	All of 4 bits of ports C, D
2. Output during reset: "L" level	All of 4 bits of ports C, D

Options of Port Output Configuration

For each input/output-common port, either of the following two output configurations may be selected by option (bitwise).

Option Name	Circuit	Conditions, etc.
1. Open drain type output		
2. Output with pull-up resistance		

Development Support

The following are available to support the LC6520, LC6522 program development.

- (1) User's Manual
"LC6554 Series User's Manual" No. E21B. (Issued in December, 1987)
- (2) Development Tool Manual
For the EVA-410 system, refer to the description of Development Support Tools in "LC6554 Series User's Manual". For the EVA-800 system, refer to "EVA-800-LC6554 Series Development Tool Manual".
- (3) Development Tools
 - 1) For program development (EVA-410 system)
 - i. MS-DOS host computer system (Note 1)
 - ii. MS-DOS base cross assembler (LC65S.EXE)
 - iii. Evaluation kit (EVA-410C or EVA-420)
 - iv. Evaluation kit target board (EVA-TB6520/22/54/43/46), evaluation chip (LC6595)
 - 2) For program evaluation
 - i. Piggyback (LC65PG20/22), with socket for conversion of number of piggyback pins

Note. For notes on program evaluation, do not fail to refer to "5-3-1. Notes on when evaluating programs for the LC6520/22" in "LC6554 Series User's Manual".

Appearance of Application Development Tools

EVA-410 System

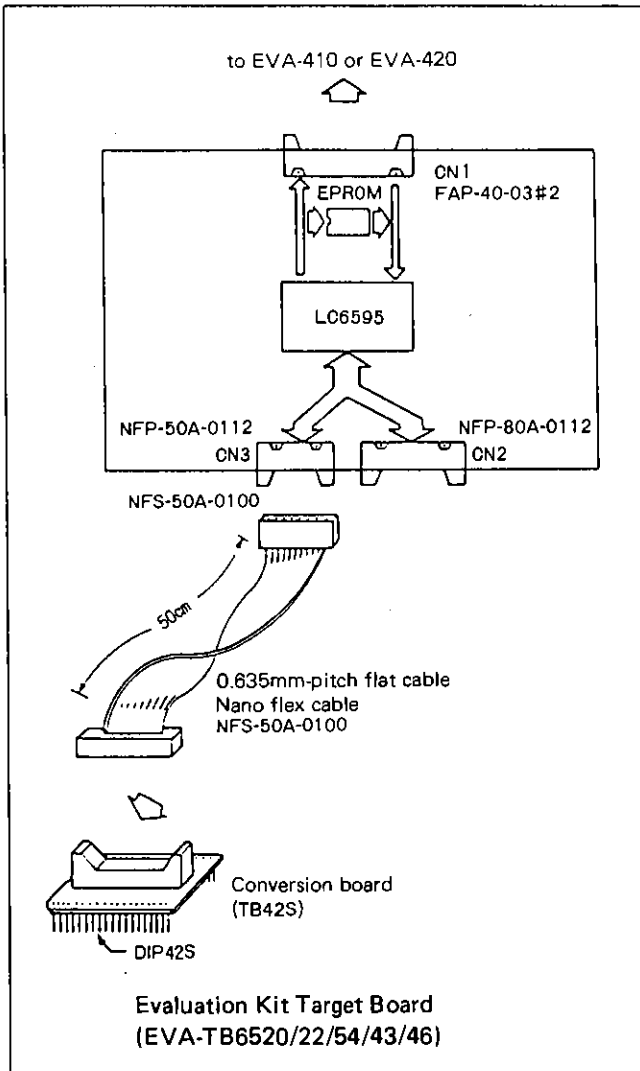

Piggyback

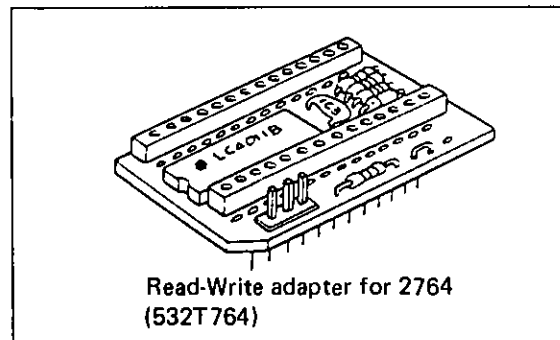
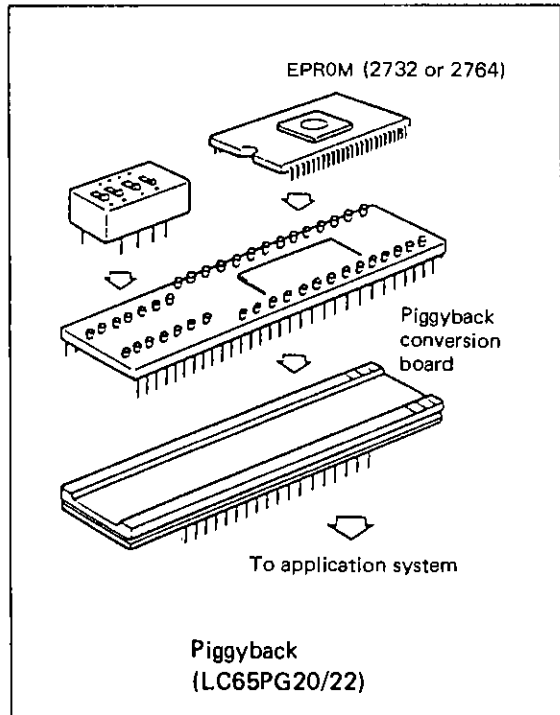

- 3) For program development (EVA-800 system)
- i. IBM PC/XT, IBM PC-AT (Note 1) compatible Sanyo MS-DOS machine
 - ii. Cross assemblerMS-DOS base cross assembler: (LC65S.EXE)
 - iii. Host control program: (EVA800.EXE)
 - iv. Evaluation chip: LC6595
 - v. Emulator : EVA-800 or EVA-850 control board and evaluation chip board (Note 2)

Appearance of Development Support System

EVA-800 System

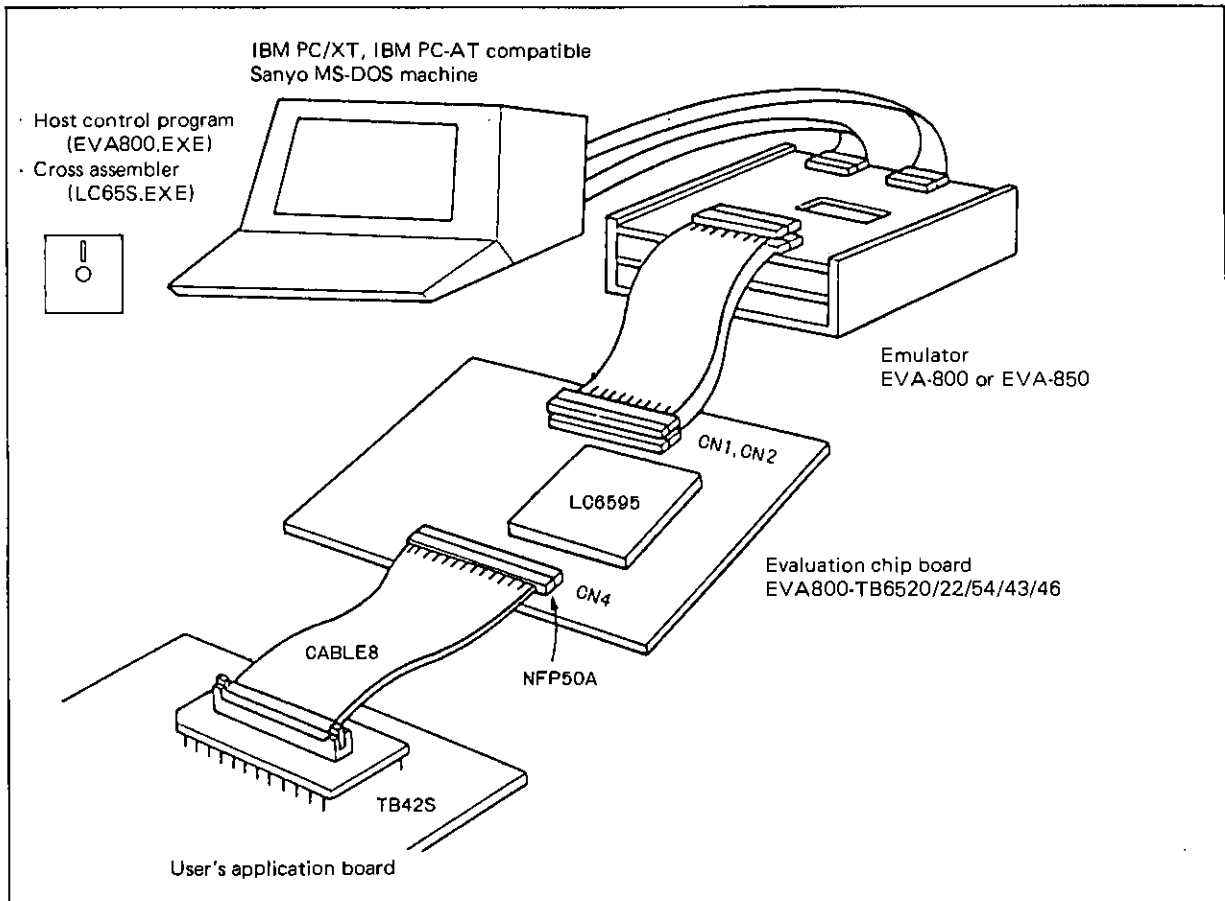

(Note 1) IBM PC/XT, IBM PC-AT: Products of IBM Corporation

MS-DOS: Trademark of Microsoft Corporation

(Note 2) The EVA-800 is a general term for emulator. A suffix (A, B ...) is added at the end of EVA-800 as the EVA-800 is improved to be a newer version. Do not use the EVA-800 with no suffix added.

Main Specifications of the LC6520C, 6522C

Absolute Maximum Ratings/ $T_a = 25^\circ\text{C}$, $V_{SS} = 0\text{V}$				unit
Maximum Supply Voltage	$V_{DD\text{ max}}$	V_{DD}	-0.3 to +7.0	V
Output Voltage	V_o	OSC2	Allowable up to voltage generated	V
Input Voltage	V_I (1)	OSC1 (Note 1)	-0.3 to $V_{DD}+0.3$	V
	V_I (2)	TEST, RES	-0.3 to $V_{DD}+0.3$	V
	V_I (3)	PB0 to 3	-0.3 to +15	V
Input/Output Voltage	V_{IO} (1)	Port of OD type	-0.3 to +15	V
	V_{IO} (2)	Port of PU type	-0.3 to $V_{DD}+0.3$	V
Peak Output Current	I_{OP}	Input/output port	-2 to +20	mA
Average Output Current	I_{OA}	Input/output port:	-2 to +20	mA
		Per pin over the period of 100 msec.		
	ΣI_{OA} (1)	Total current of PA0 to 3, PC0 to 3, PD0 to 3 and PE0 to 3 (Note 2)	-30 to +140	mA
	ΣI_{OA} (2)	Total current of PF0 to 3, PG0 to 3, PI0 to 3 and PJ0 to 3.(Note 2)	-30 to +140	mA
Allowable Power Dissipation	$P_d\text{ max}$ (1)	DIP package, $T_a = -30$ to $+70^\circ\text{C}$	600	mW
	$P_d\text{ max}$ (2)	QIP package, $T_a = -30$ to $+70^\circ\text{C}$	400	mW
Operating Temperature	T_{opr}		-30 to +70	$^\circ\text{C}$
Storage Temperature	T_{stg}		-55 to +125	$^\circ\text{C}$

Allowable Operating Conditions/ $T_a = -30$ to $+70^\circ\text{C}$, $V_{SS} = 0\text{V}$, $V_{DD} = 3.0$ to 5.5V				min	typ	max	unit	
Operating Supply Voltage	V_{DD}	V_{DD}	3.0			5.5	V	
Standby Supply Voltage	V_{st}	V_{DD} : RAM, resister hold (Note 3)	1.8			5.5	V	
"H"-Level Input Voltage	V_{IH} (1)	Port of OD type, PB0 to 3: Output Nch Tr OFF	$0.7V_{DD}$			+13.5	V	
	V_{IH} (2)	Port of PU type: Output Nch Tr OFF	$0.7V_{DD}$			V_{DD}	V	
	V_{IH} (3)	\overline{SCK} , SI, \overline{INT} of OD type: Output Nch Tr OFF	$0.8V_{DD}$			+13.5	V	
	V_{IH} (4)	\overline{SCK} , SI, \overline{INT} of PU type: Output Nch Tr OFF	$0.8V_{DD}$			V_{DD}	V	
	V_{IH} (5)	RES	$0.8V_{DD}$			V_{DD}	V	
	V_{IH} (6)	OSC1: External clock mode	$0.8V_{DD}$			V_{DD}	V	
	"L"-Level Input Voltage	V_{IL} (1)	PORT: $V_{DD} = 4$ to 5.5V , Output Nch Tr OFF	V_{SS}			$0.3V_{DD}$	V
		V_{IL} (2)	PORT: Output Nch Tr OFF	V_{SS}			$0.25V_{DD}$	V
		V_{IL} (3)	\overline{INT} , \overline{SCK} , SI: $V_{DD} = 4$ to 5.5V Output Nch Tr OFF	V_{SS}			$0.25V_{DD}$	V
		V_{IL} (4)	\overline{INT} , \overline{SCK} , SI: Output Nch Tr OFF	V_{SS}			$0.2V_{DD}$	V
V_{IL} (5)		OSC1: $V_{DD} = 4$ to 5.5V , External clock mode	V_{SS}			$0.25V_{DD}$	V	
V_{IL} (6)		OSC1: External clock mode	V_{SS}			$0.2V_{DD}$	V	
V_{IL} (7)		TEST: $V_{DD} = 4$ to 5.5V	V_{SS}			$0.3V_{DD}$	V	
V_{IL} (8)		TEST	V_{SS}			$0.25V_{DD}$	V	
V_{IL} (9)		RES: $V_{DD} = 4$ to 5.5V	V_{SS}			$0.25V_{DD}$	V	
V_{IL} (10)		RES	V_{SS}			$0.2V_{DD}$	V	
Operating Frequency (Cycle Time)	f_{op} (T_{cyc})	($V_{DD} = 4.0$ to 5.5V)	(2.77) (6.0)		See Table 2.	(20) (20)	(μs) (μs)	

Continued on next page.

Continued from preceding page.

External Clock Conditions (When the external clock or 2-pin RC OSC option is selected)			min	typ	max	unit
Frequency	f_{ext}	OSC1: Fig. 1		See Table 2.		
Pulse Width	t_{extH}	OSC1: $V_{DD} = 4$ to $5.5V$, Fig. 1	90			ns
	t_{extL}	OSC1: Fig. 1	180			ns
Rise/Fall Time	t_{extR}	OSC1: $V_{DD} = 4$ to $5.5V$, Fig. 1			30	ns
	t_{extF}	OSC1: Fig. 1			100	ns
Oscillation Guaranteed Constants						
2-Pin RC Oscillation	C_{ext}	OSC1, OSC2: $V_{DD} = 4$ to $5.5V$, Fig. 2		220±5%		pF
	R_{ext}	OSC1, OSC2: $V_{DD} = 4$ to $5.5V$, Fig. 2		6.8±1%		kΩ
	C_{ext}	OSC1, OSC2: Fig. 2		270±5%		pF
	R_{ext}	OSC1, OSC2: Fig. 2		15±1%		kΩ
Ceramic Resonator Oscillation		Fig. 3		See Table 1.		
Electrical Characteristics/$T_a = -30$ to $+70^\circ C$, $V_{SS} = 0V$, $V_{DD} = 3.0$ to $5.5V$						
"H"-Level Input Current	I_{IH} (1)	Port of open drain type, PB0 to 3: Output Nch Tr OFF, Including OFF leakage current of Nch Tr, $V_{IN} = +13.5V$			+5.0	μA
"L"-Level Input Current	I_{IH} (2)	OSC1: External clock mode, $V_{IN} = V_{DD}$			+1.0	μA
	I_{IL} (1)	Port of open drain type, PB0 to 3: Output Nch Tr OFF, $V_{IN} = V_{SS}$	-1.0			μA
	I_{IL} (2)	Port with pull-up resistance: Output Nch Tr OFF, $V_{IN} = V_{SS}$	-1.3	-0.35		mA
	I_{IL} (3)	RES: $V_{IN} = V_{SS}$	-45	-10		μA
	I_{IL} (4)	OSC1: External clock mode, $V_{IN} = V_{SS}$	-1.0			μA
"H"-Level Output Voltage	V_{OH} (1)	Port with pull-up resistance: $V_{DD} = 4$ to $5.5V$, $I_{OH} = -50 \mu A$		$V_{DD}-1.2$		V
	V_{OH} (2)	Port with pull-up resistance: $I_{OH} = -10 \mu A$		$V_{DD}-0.5$		V
"L"-Level Output Voltage	V_{OL} (1)	Port: $V_{DD} = 4$ to $5.5V$, $I_{OL} = 10 mA$			1.5	V
	V_{OL} (2)	Port: $I_{OL} = 1 mA$, When I_{OL} of each port is 1 mA or less.			0.5	V
Hysteresis Voltage	V_{Hys}	RES, INT, SCR, SI, OSC1 of Schmitt type (Note 6)		$0.1V_{DD}$		V
Current Dissipation						
2-Pin RC Oscillation	I_{DDOP} (1)	Operation mode, Output Nch Tr OFF, Port = V_{DD} V_{DD} : $V_{DD} = 4$ to $5.5V$, Fig. 2 $f_{osc} = 750 kHz$ typ		2	5	mA
	I_{DDOP} (2)	V_{DD} : Fig. 2 $f_{osc} = 350 kHz$ typ		1.5	4.5	mA
Ceramic Resonator Oscillation	I_{DDOP} (3)	V_{DD} : Fig. 3 $V_{DD} = 4$ to $5.5V$, 4MHz, 1/3 predivider		5	10	mA
	I_{DDOP} (4)	V_{DD} : Fig. 3 $V_{DD} = 4$ to $5.5V$, 4MHz, 1/4 predivider		5	10	mA
	I_{DDOP} (5)	V_{DD} : Fig. 3 400kHz		1.5	4	mA
External Clock	I_{DDOP} (6)	V_{DD} : $V_{DD} = 4$ to $5.5V$, Fig. 3 800kHz		2	5	mA
	I_{DDOP} (7)	V_{DD} : 200 kHz to 667 kHz, 1/1 predivider 600 kHz to 2000 kHz, 1/3 predivider 800 kHz to 2667 kHz, 1/4 predivider		2	5	mA
	I_{DDOP} (8)	V_{DD} : $V_{DD} = 4$ to $5.5V$, 200 kHz to 1444 kHz, 1/1 predivider 600 kHz to 4330 kHz, 1/3 predivider 800 kHz to 4330 kHz, 1/4 predivider		3	10	mA
Standby Mode	I_{DDSt}	V_{DD} : $V_{DD} = 5.5V$ (Output Nch Tr OFF, V_{DD} : $V_{DD} = 3V$ (Port = V_{DD})		0.05 0.025	10 5	μA μA

Continued on next page.

LC6520C ,6520H ,6522C ,6522H

Continued from preceding page.

		min	typ	max	unit
Oscillation Characteristics					
Ceramic Resonator Oscillation					
Oscillation Frequency	f _{CFOSC} (Note 4)	OSC1, OSC2: Fig. 3 f ₀ = 400 kHz	392	400	408 kHz
		OSC1, OSC2: V _{DD} = 4 to 5.5V, Fig. 3 f ₀ = 800 kHz	784	800	816 kHz
		OSC1, OSC2: V _{DD} = 4 to 5.5V, Fig. 3 f ₀ = 3 MHz, 1/3 predivider, 1/4 predivider	2940	3000	3060 kHz
		OSC1, OSC2: V _{DD} = 4 to 5.5V, Fig. 3 f ₀ = 4 MHz, 1/3 predivider, 1/4 predivider	3920	4000	4080 kHz
Oscillation Stabilizing Period	t _{CFS}	Fig. 4 f ₀ = 400 kHz V _{DD} = 4 to 5.5V, Fig. 4 f ₀ = 4 MHz, 3 MHz, 800 kHz			10 ms 10 ms
2-Pin RC Oscillation					
Oscillation Frequency	f _{MOSC} (1)	OSC1, OSC2: V _{DD} = 4 to 5.5V, Fig. 2, C _{ext} = 220 pF±5%, R _{ext} = 6.8 kΩ±1%	515	750	1156 kHz
	f _{MOSC} (2)	OSC1, OSC2: Fig. 2, C _{ext} = 270 pF±5%, R _{ext} = 15 kΩ±1%	222	350	609 kHz
Pull-up Resistance					
I/O Port Pull-up Resistance	R _{pp}	Port of PU type: V _{DD} = 5V		14	kΩ
External Reset Characteristics					
"H"-Level Threshold	V _{tH}		0.5V _{DD}	0.8V _{DD}	V
"L"-Level Threshold	V _{tL}		0.2V _{DD}	0.5V _{DD}	V
Reset Time	T _{RST}		See Fig. 5.		
Pin Capacitance	CP	f = 1 MHz, Other than pins to be tested, V _{IN} = V _{SS}		10	pF
Serial Clock					
Input Clock Cycle Time	t _{CKCY} (1)	$\overline{\text{SCK}}$: V _{DD} = 4 to 5.5V, Fig. 6	3.0		μs
		SCK	12.0		μs
Output Clock Cycle Time	t _{CKCY} (2)	$\overline{\text{SCK}}$ (T _{CYC} = 4 x System clock period), Fig. 6	64 x T _{CYC}		μs
Input Clock "L"-Level Pulse Width	t _{CKL} (1)	$\overline{\text{SCK}}$: V _{DD} = 4 to 5.5V, Fig. 6	1.0		μs
			SCK	4.0	
Output Clock "L"-Level Pulse Width	t _{CKL} (2)	$\overline{\text{SCK}}$, Fig. 6	32 x T _{CYC}		μs
Input Clock "H"-Level Pulse Width	t _{CKH} (1)	$\overline{\text{SCK}}$: V _{DD} = 4 to 5.5V, Fig. 6	1.0		μs
			SCK	4.0	
Output Clock "H"-Level Pulse Width	t _{CKH} (2)	$\overline{\text{SCK}}$: Fig. 6	32 x T _{CYC}		μs
Serial Input					
Data Setup Time	t _{ICK}	SI: Specified for ↑ of $\overline{\text{SCK}}$, Fig. 6	0.5		μs
Data Hold Time	t _{CKI}	SI: Specified for ↑ of $\overline{\text{SCK}}$, Fig. 6	0.5		μs
Serial Output					
Output Delay Time	t _{CKO}	SO: V _{DD} = 4 to 5.5V, Specified for ↓ of $\overline{\text{SCK}}$, Nch OD only: External 1 kohm, external 50 pF, Fig. 6			0.5 μs
		SO			2.0 μs
Pulse Output					
Period	t _{PCY}	PE0: T _{CYC} = 4 x System clock period, Nch OD only: External 1 kohm, external 50 pF, Fig. 7	64 x T _{CYC}		μs
"H"-Level Pulse Width	t _{PH}	PE0:	32 x T _{CYC} ±10%		μs
"L"-Level Pulse Width	t _{PL}	PE0:	32 x T _{CYC} ±10%		μs

Note 1: When oscillated internally under the oscillating conditions in Fig. 3, up to the oscillation amplitude generated is allowable.

Note 2: Average over the period of 100 msec.

Note 3: Operating supply voltage V_{DD} must be held until the standby mode is entered after the execution of the HALT instruction.
The PA3 (or PA0 to 3) pin must be free from chattering during the HALT instruction execution cycle.

Note 4: f_{CFOSC} represents an oscillatable frequency. There is a tolerance of approximately 1% between the center frequency at the ceramic mode and the nominal value presented by the ceramic resonator supplier. For details, refer to the specification for the ceramic resonator.

Note 5: When mounting the OIP version on the board, do not dip it in solder.

Note 6: The OSC1 becomes the Schmitt type when the OSC option is the 2-pin RC OSC or external clock OSC.

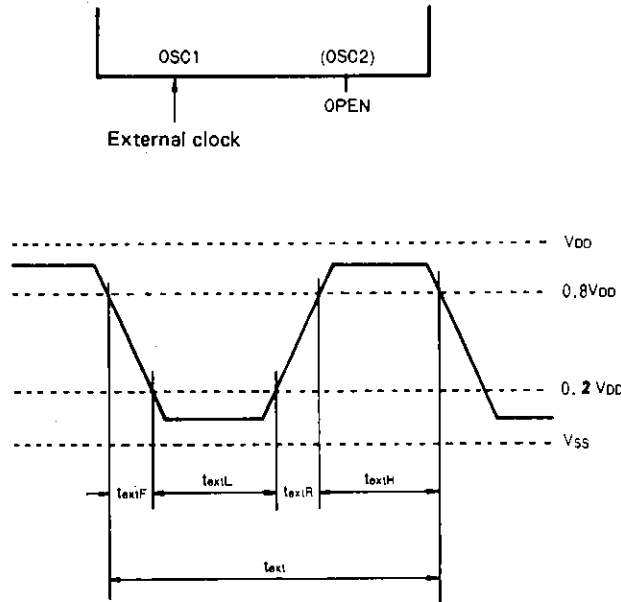

Fig. 1 External Clock Input Waveform

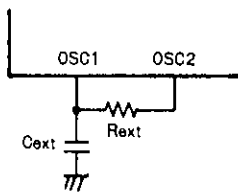

Fig. 2 2-Pin RC Oscillation Circuit

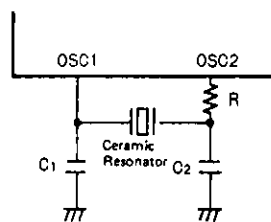

Fig. 3 Ceramic Resonator Oscillation Circuit

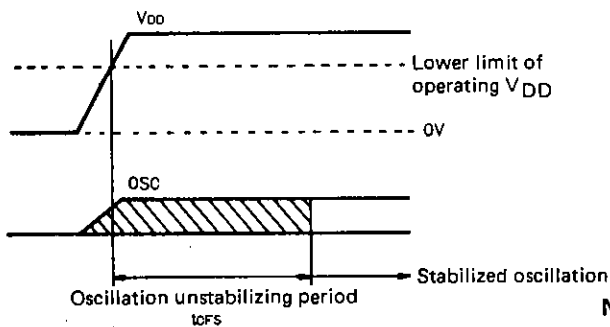

Fig. 4 Oscillation Stabilizing Period

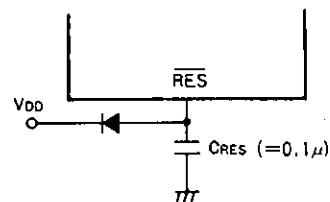

Fig. 5 Reset Circuit

Note 7: When the rise time of the power supply is 0, the reset time becomes 10 ms to 100 ms at $C_{RES} = 0.1 \mu F$. If the rise time of the power supply is long, the value of C_{RES} must be increased so that the reset time becomes 10 ms or greater.

4MHz (Murata) CSA4.00MG	C1	33pF ± 10%	800kHz (Murata) CSB800D CSB800K	C1	220pF ± 10%
	C2	33pF ± 10%		C2	220pF ± 10%
	R	0Ω		R	0Ω
4MHz (Kyocera) KBR4.0MS	C1	33pF ± 10%	800kHz (Kyocera) KBR800H	C1	150pF ± 10%
	C2	33pF ± 10%		C2	150pF ± 10%
	R	0Ω		R	0Ω
3MHz (Murata) CSA3.00MG	C1	33pF ± 10%	400kHz (Murata) CSB400P	C1	470pF ± 10%
	C2	33pF ± 10%		C2	470pF ± 10%
	R	0Ω		R	0Ω
3MHz (Kyocera) KBR3.0MS	C1	47pF ± 10%	400kHz (Kyocera) KBR400B	C1	330pF ± 10%
	C2	47pF ± 10%		C2	330pF ± 10%
	R	0Ω		R	0Ω

Table 1 Constants Guaranteed for Ceramic Resonator Oscillation

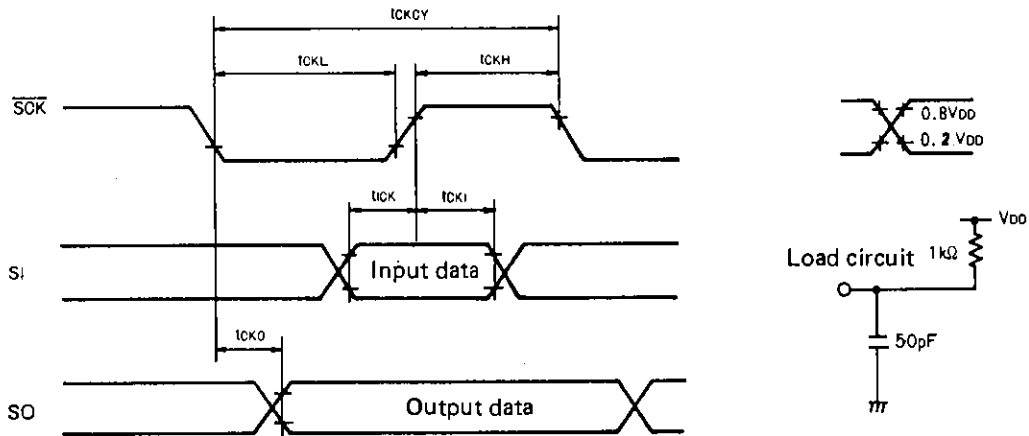

Fig. 6 Serial Input/Output Timing

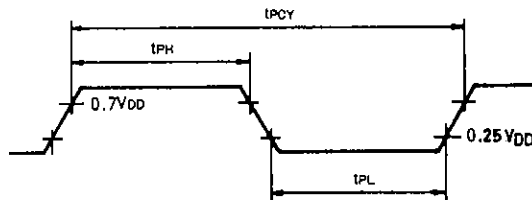

Fig. 7 Pulse Output Timing at Port PE0

The load conditions are the same as in Fig. 6.

Circuit Configuration	Frequency	Predivider Option (Cycle Time)	V _{DD}	Remarks
Ceramic Resonator Option	400 kHz	1/1 (10 μs)	3 to 5.5V	Unusable with 1/3, 1/4 predivider
	800 kHz	1/1 (5 μs) 1/3 (15 μs) 1/4 (20 μs)	4 to 5.5V 4 to 5.5V 4 to 5.5V	
	3 MHz	1/3 (4 μs) 1/4 (5.33 μs)	4 to 5.5V 4 to 5.5V	Unusable with 1/1 predivider
	4 MHz	1/3 (3 μs) 1/4 (4 μs)	4 to 5.5V 4 to 5.5V	Unusable with 1/1 predivider
External Clock Option or External Clock Drive by RC OSC Option	200 to 667 kHz	1/1 (20 to 6 μs)	3 to 5.5V	
	600 to 2000 kHz	1/3 (20 to 6 μs)	3 to 5.5V	
	800 to 2667 kHz	1/4 (20 to 6 μs)	3 to 5.5V	
	200 to 1444 kHz	1/1 (20 to 2.77 μs)	4 to 5.5V	
	600 to 4330 kHz	1/3 (20 to 2.77 μs)	4 to 5.5V	
	800 to 4330 kHz	1/4 (20 to 3.70 μs)	4 to 5.5V	
External Clock Drive by ceramic resonator OSC Option	The external clock drive is impossible. When using the external clock drive, specify the external clock option or RC OSC option.			
RC OSC Option	Used with 1/1 predivider, recommended constants (V _{DD} = 4 to 5.5V, V _{DD} = 3 to 5.5V). If used with other than recommended constants, the predivider option, frequency, V _{DD} range must be the same as for the external clock option.			

Table 2 Table of Oscillation, Predivider Option (All selectable combinations are shown. Do not use any other combinations than shown above.)

RC Oscillation Characteristic of the LC6520C, 6522C

Fig. 8 shows the RC oscillation characteristic of the LC6520C, 6522C. For the variation range of RC OSC frequency of the LC6520C, 6522C, the following are guaranteed at the external constants only shown below.

- 1) V_{DD} = 3.0V to 5.5V, T_a = -30°C to +70°C
 External constants C_{ext} = 270 pF, R_{ext} = 15 kohms
 222 kHz ≤ f_{mosc} ≤ 609 kHz
- 2) V_{DD} = 4.0V to 5.5V, T_a = -30°C to +70°C
 External constants C_{ext} = 220 pF, R_{ext} = 6.8 kohms
 515 kHz ≤ f_{mosc} ≤ 1156 kHz

If any other constants than specified above are used, the range of R_{ext} = 4 kohms to 23 kohms, C_{ext} = 150 pF to 400 pF must be observed. (See Fig. 8.)

Note 8: The oscillation frequency at V_{DD} = 5.0V, T_a = 25°C must be in the range of 350 kHz to 750 kHz.

Note 9: The oscillation frequency at V_{DD} = 4.0V to 5.5V, T_a = -30°C to +70°C and V_{DD} = 3.0V to 5.5V, T_a = -30°C to +70°C must be within the operation clock frequency range. (See Table 2.)

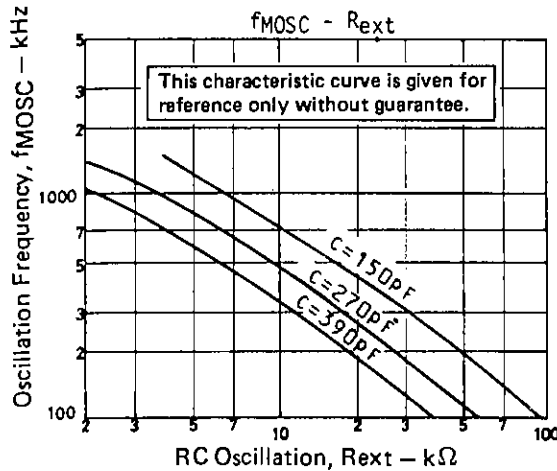

Fig. 8 RC Oscillation Frequency Data (Typ.)

Main Specifications of the LC6520H, 6522H

Absolute Maximum Ratings/T _a = 25°C, V _{SS} = 0V			unit
Maximum Supply Voltage	V _{DD} max	V _{DD}	-0.3 to +7.0 V
Output Voltage	V _o	OSC2	Allowable up to voltage generated V
Input Voltage	V _I (1)	OSC1 (Note 1)	-0.3 to V _{DD} +0.3 V
	V _I (2)	TEST, \overline{RES}	-0.3 to V _{DD} +0.3 V
	V _I (3)	PB ₀ to 3	-0.3 to +15 V
Input/Output Voltage	V _{IO} (1)	Port of OD type	-0.3 to +15 V
	V _{IO} (2)	Port of PU type	-0.3 to V _{DD} +0.3 V
Peak Output Current	I _{OP}	Input/output port	-2 to +20 mA
Average Output Current	I _{OA}	Input/output port: Per pin over the period of 100 msec.	-2 to +20 mA
	ΣI _{OA} (1)	Total current of PA ₀ to 3, PC ₀ to 3, PD ₀ to 3, and PE ₀ to 3 (Note 2)	-30 to +140 mA
	ΣI _{OA} (2)	Total current of PF ₀ to 3, PG ₀ to 3, and PI ₀ to 3, PJ ₀ to 3 (Note 2)	-30 to +140 mA
Allowable Power Dissipation	P _d max (1)	DIP package, T _a = -30 to +70°C	600 mW
	P _d max (2)	QIP package, T _a = -30 to +70°C	400 mW
Operating Frequency	T _{opg}		-30 to +70 °C
Storage Temperature	T _{stg}		-55 to +125 °C

Allowable Operating Conditions/T _a = -30 to +70°C, V _{SS} = 0V, V _{DD} = 4.5 to 5.5V			min	typ	max	unit
Operating Supply Voltage	V _{DD}	V _{DD}	4.5		5.5	V
Standby Supply Voltage	V _{st}	V _{DD} : RAM, resister hold (Note 3)	1.8		5.5	V
"H"-Level Input Voltage	V _{IH} (1)	Port of OD type, PB ₀ to 3: Output Nch Tr OFF	0.7V _{DD}		+13.5	V
	V _{IH} (2)	Port of PU type: Output Nch Tr OFF	0.7V _{DD}		V _{DD}	V
	V _{IH} (3)	\overline{SCK} , SI, \overline{INT} : Output Nch Tr OFF	0.8V _{DD}		+13.5	V
	V _{IH} (4)	\overline{SCK} , SI, \overline{INT} : Output Nch Tr OFF	0.8V _{DD}		V _{DD}	V
	V _{IH} (5)	\overline{RES}	0.8V _{DD}		V _{DD}	V
	V _{IH} (6)	OSC1: External clock mode	0.8V _{DD}		V _{DD}	V
"L"-Level Input Voltage	V _{IL} (1)	Port: Output Nch Tr OFF	V _{SS}		0.3V _{DD}	V
	V _{IL} (2)	\overline{INT} , \overline{SCK} , SI: Output Nch Tr OFF	V _{SS}		0.25V _{DD}	V
	V _{IL} (3)	OSC1: External clock mode	V _{SS}		0.25V _{DD}	V
	V _{IL} (4)	TEST	V _{SS}		0.3V _{DD}	V
	V _{IL} (5)	\overline{RES}	V _{SS}		0.25V _{DD}	V
Operating Frequency (Cycle Time)	f _{op} (T _{cyc})		See Table 2. (0.92)		(20)	(μs)

External Clock Conditions (When the external clock option is selected)				
Frequency	f _{ext}	OSC1: Fig. 1	See Table 2.	
Pulse Width	t _{extH}	OSC1: Fig. 1	90	ns
	t _{extL}			
Rise/Fall Time	t _{extR}	OSC1: Fig. 1		30 ns
	t _{extF}			

Oscillation Guaranteed Constants			
Ceramic Resonator Oscillation		Fig. 2	See Table 1.

Electrical Characteristics/ $T_a = -30$ to $+70^\circ\text{C}$, $V_{SS} = 0\text{V}$, $V_{DD} = 4.5$ to 5.5V		min	typ	max	unit			
"H"-Level Input Current	I_{IH} (1)	Port of open drain type, PB_0 to 3: Output Nch Tr OFF, Including Nch Tr OFF leakage current, $V_{IN} = 13.5\text{V}$			+5.0	μA		
"L"-Level Input Current	I_{IH} (2)	OSC1: External clock mode, $V_{IN} = V_{DD}$			+1.0	μA		
	I_{IL} (1)	Port of open drain type, PB_0 to 3: Output Nch Tr OFF, $V_{IN} = V_{SS}$			-1.0	μA		
	I_{IL} (2)	Port with pull-up resistance: Output Nch Tr OFF, $V_{IN} = V_{SS}$			-1.3	-0.35	mA	
	I_{IL} (3)	RES: $V_{IN} = V_{SS}$			-45	-10	μA	
"H"-Level Output Voltage	I_{IL} (4)	OSC1: External clock mode, $V_{IN} = V_{SS}$			-1.0	μA		
	V_{OH} (1)	Port with pull-up resistance: $I_{OH} = -50 \mu\text{A}$			$V_{DD}-1.2$	V		
"L"-Level Output Voltage	V_{OH} (2)	Port with pull-up resistance: $I_{OH} = -10 \mu\text{A}$			$V_{DD}-0.5$	V		
	V_{OL} (1)	Port: $I_{OL} = 10 \text{mA}$			1.5	V		
Hysteresis Voltage	V_{OL} (2)	Port: $I_{OL} = 1 \text{mA}$, When I_{OL} of each port is 1 mA or less.			0.5	V		
	V_{Hys}	RES, INT, SCK, SI, OSC1 of Schmitt type (Note 6)			$0.1V_{DD}$	V		
Current Dissipation								
Ceramic Resonator Oscillation	I_{DDOP} (1)	V_{DD} : Fig. 2, 4MHz, Operating mode, Output Nch Tr OFF, Port = V_{DD}			5	10	mA	
External Clock	I_{DDOP} (2)	V_{DD} : 200 kHz to 4330 kHz, Operating mode, Output Nch Tr OFF, Port = V_{DD}			5	10	mA	
Standby Mode	I_{DDST}	V_{DD} : $V_{DD} = 5.5\text{V}$ (Output Nch Tr OFF, Port = V_{DD})			0.05	10	μA	
		V_{DD} : $V_{DD} = 3\text{V}$ (Port = V_{DD})			0.025	5	μA	
Oscillation Characteristics								
Ceramic Resonator Oscillation								
Oscillation Frequency	f_{CFOSC} (Note 4)	OSC1, OSC2: Fig. 2 $f_0 = 4 \text{MHz}$			3920	4000	4080	kHz
Oscillation Stabilizing Period	t_{CFS}	Fig. 3 $f_0 = 4 \text{MHz}$				10		ms
Pull-up Resistance								
I/O Port Pull-up Resistance	R_{pp}	Port of PU type: $V_{DD} = 5\text{V}$			14			$\text{k}\Omega$
External Reset Characteristics								
"H"-Level Threshold	V_{tH}				$0.5V_{DD}$	$0.8V_{DD}$		V
"L"-Level Threshold	V_{tL}				$0.25V_{DD}$	$0.5V_{DD}$		V
Reset Time	$TRST$				See Fig. 4.			
Pin Capacitance	CP	$f = 1 \text{MHz}$, Other than pins to be tested, $V_{IN} = V_{SS}$			10			pF
Serial Clock								
Input Clock Cycle Time	t_{CKCY} (1)	$\overline{\text{SCK}}$: Fig. 5			3.0			μs
Output Clock Cycle Time	t_{CKCY} (2)	$\overline{\text{SCK}}$: ($T_{CYC} = 4 \times$ System clock period), Fig. 5			$64 \times T_{CYC}$			μs
Input Clock "L"-Level Pulse Width	t_{CKL} (1)	$\overline{\text{SCK}}$: Fig. 5			1.0			μs
Output Clock "L"-Level Pulse Width	t_{CKL} (2)	$\overline{\text{SCK}}$: Fig. 5			$32 \times T_{CYC}$			μs

Continued on next page.

Continued from preceding page.

			min	typ	max	unit
Input Clock "H"-Level Pulse Width	$t_{CKH(1)}$	\overline{SCK} : Fig. 5	1.0			μs
Output Clock "H"-Level Pulse Width	$t_{CKH(2)}$	\overline{SCK} : Fig. 5		$32 \times T_{CYC}$		μs
Serial Input						
Data Setup Time	t_{ICK}	SI: Specified for \uparrow of \overline{SCK} , Fig. 5	0.5			μs
Data Hold Time	t_{CKI}	SI: Specified for \uparrow of \overline{SCK} , Fig. 5	0.5			μs
Serial Output						
Output Delay Time	t_{CKO}	SO: Specified for \downarrow of \overline{SCK} , Nch OD only: External 1 kohm, external 50 pF, Fig. 5			0.5	μs
Pulse Output						
Period	t_{PCY}	PE0: $T_{CYC} = 4 \times$ System clock period, Nch OD only: External 1 kohm, external 50 pF, Fig. 6		$64 \times T_{CYC}$		μs
"H"-Level Pulse Width	t_{PH}	PE0:		$32 \times T_{CYC} \pm 10\%$		μs
"L"-Level Pulse Width	t_{PL}	PE0:		$32 \times T_{CYC} \pm 10\%$		μs

Note 1: When oscillated internally under the oscillating conditions in Fig. 2, up to the oscillation amplitude generated is allowable.

Note 2: Average over the period of 100 msec.

Note 3: Operating supply voltage V_{DD} must be held until the standby mode is entered after the execution of the HALT instruction. The PA3 (or PA0 to 3) pin must be free from chattering during the HALT instruction execution cycle.

Note 4: f_{COSC} represents an oscillatable frequency. There is a tolerance of approximately 1% between the center frequency at the ceramic mode and the nominal value presented by the ceramic resonator supplier. For details, refer to the specification for the ceramic resonator.

Note 5: When mounting the QIP version on the board, do not dip it in solder.

Note 6: The OSC1 becomes the Schmitt type when the OSC option is the external clock OSC.

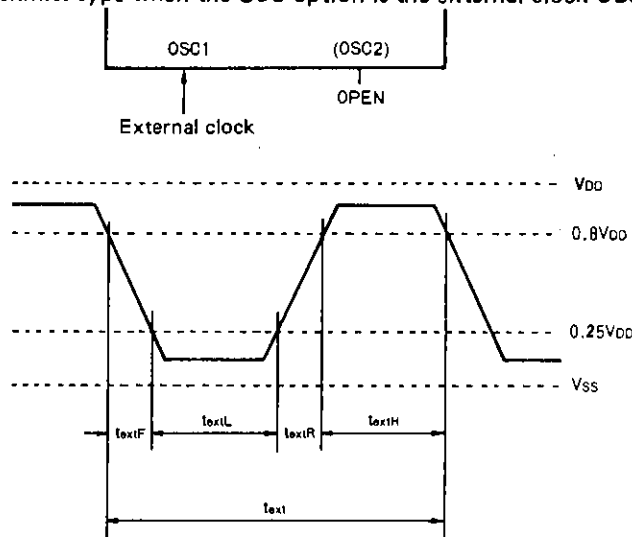

Fig. 1 External Clock Input Waveform

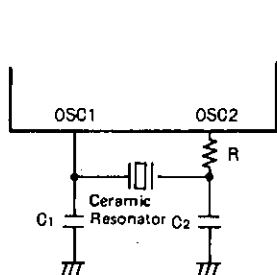

Fig. 2 Ceramic Resonator Oscillation Circuit

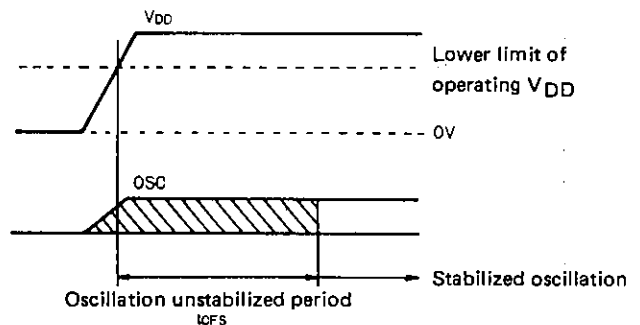

Fig. 3 Oscillation Stabilizing Preiod

4MHz (Murata) CSA4.00MG	C1	33pF ± 10%
	C2	33pF ± 10%
	R	0Ω
4MHz (Kyocera) KBR4.0MS	C1	33pF ± 10%
	C2	33pF ± 10%
	R	0Ω

Table 1 Constants Guaranteed for Ceramic Resonator Oscillation

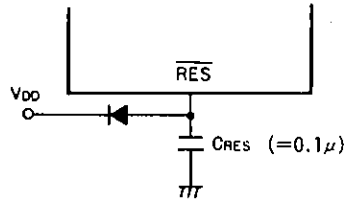

Fig. 4 Reset Circuit

Note 7: When the rise time of the power supply is 0, the reset time becomes 10 ms to 100 ms at $C_{RES} = 0.1 \mu F$. If the rise time of the power supply is long, the value of C_{RES} must be increased so that the reset time becomes 10 ms or greater.

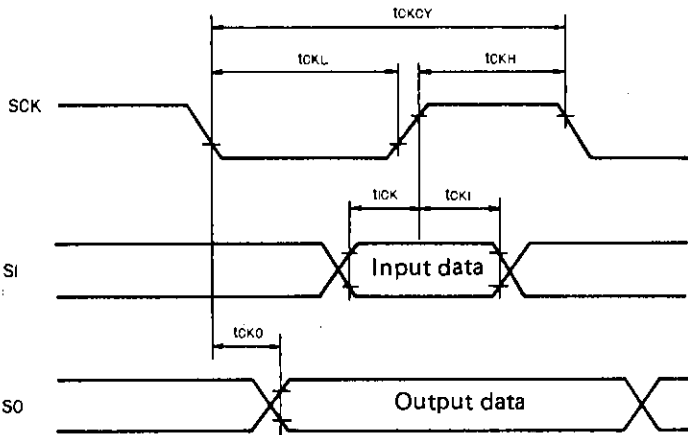

Fig. 5 Serial Input/Output Timing

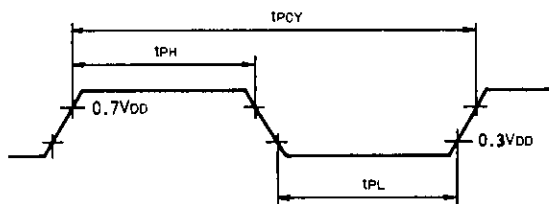
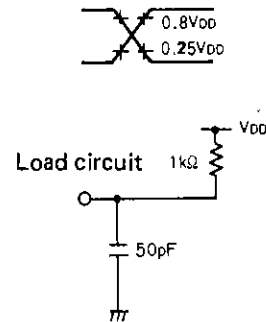

Fig. 6 Pulse Output Timing at Port PE0

The load conditions are the same as in Fig. 5.

Circuit Configuration	Frequency	Predivider Option (Cycle Time)	VDD	Remarks
Ceramic Resonator OSC Option	4 MHz	1/1 (1 μs)	4.5 to 5.5V	
External Clock Option	200 to 4330 kHz	1/1 (20 to 0.92 μs)	4.5 to 5.5V	
External Clock Drive by Ceramic Resonator OSC Option	The external clock drive is impossible. When using the external clock drive, specify the external clock option.			

Table 2 Table of Oscillation, Predivider Option (All selectable combinations are shown. Do not use any other combinations than shown above.)

Notes for Standby Function Application

The LC6520, LC6522 provide the standby function called HALT mode to minimize the current dissipation when the program is in the wait state.

The standby function is controlled by the HALT instruction, PA pin, $\overline{\text{RES}}$ pin, and serial transfer completion signal. A peripheral circuit and program must be so designed as to provide precise control of the standby function. In most applications where the standby function is performed, voltage regulation, instantaneous break of power, and external noise are not negligible. When designing an application circuit and program, whether or not to take some measures must be considered according to the extent to which these factors are allowed. This section mainly describes power failure backup for which the standby function is mostly used. A sample application circuit where the standby function is performed precisely is shown below and notes for circuit design and program design are also given below.

When using the standby function, the application circuit shown below must be used and the notes must be also fully observed.

If any other method than shown in this section is applied, it is necessary to fully check the environmental conditions such as power failure and the actual operation of an application equipment.

1. HALT mode release conditions

1-1. Supplementary description of release by serial transfer completion signal

On completion of serial transfer, the HALT mode is released and the execution of the program starts with an instruction immediately following the HALT instruction. This function can be used to execute the program only when serial transfer occurs, placing the program in the wait state when no serial transfer occurs. This function is effective in reducing the current dissipation or clock noise.

— Notes —

- Release by the serial transfer completion signal is available only when the RC mode is used for system clock generation; and unavailable when the ceramic mode is used.
- On completion of serial transfer, the HALT mode is released unconditionally. In an application, such as capacitor backup application, where the current dissipation must be kept as low as possible during backup and serial transfer by external clock is also used, the HALT mode is released when serial data is transferred externally during backup.

1-2. Summary of HALT release conditions

The HALT mode setting, release conditions are shown in Table 1.

Table 1 HALT mode setting, release conditions

HALT mode setting conditions	HALT mode release conditions
HALT instruction Provided that PA ₃ , (PA ₃ to PA ₀ or PA ₃ is program-selectable) is at high level.	1 Reset (Low level is applied to $\overline{\text{RES}}$.) 2 Low level is applied to PA ₃ , (PA ₃ to PA ₀ or PA ₃ is program-selectable.) 3 Serial transfer completion.

Note) HALT mode release conditions (2), (3) are available only when the RC mode is used for system clock generation; and unavailable when the ceramic mode is used.

2. Proper cares in using standby function

When using the standby function, an application circuit and program must be designed with the following in mind.

- (1) The supply voltage at the standby state must not be less than specified.
- (2) Input timing and conditions of each control signal ($\overline{\text{RES}}$, port A, serial transfer) must be observed at the standby initiate/release state.
- (3) Release operation must not be overlapped at the time of execution of the HALT instruction.

A sample application where the standby function is used for power failure backup is shown below as a concrete method to observe these notes. A sample application circuit, its operation, and notes for program design are given below.

Sample application where the standby function is used for power failure backup

Power failure backup is an application where power failure of the main power source is detected and the HALT instruction is executed to cause the standby state to be entered. The current dissipation is minimized and a backup capacitor is used to retain the contents of the internal registers for a certain period of time. After power is restored, a reset occurs automatically and the execution of the program starts at address 000H of the program counter (PC). Shown below are sample applications where the program selects or not between power-ON reset and reset after power is restored, notes, measures for instantaneous break of AC power, and notes for serial transfer.

2-1. Sample application 1 where the standby function is used for power failure backup

Shown below is a sample application where the program does not select between power-ON reset and reset after power is restored.

2-1-1. Sample application circuit – (1)

Fig. 2-1 shows a sample application where the standby function is used for power failure backup.

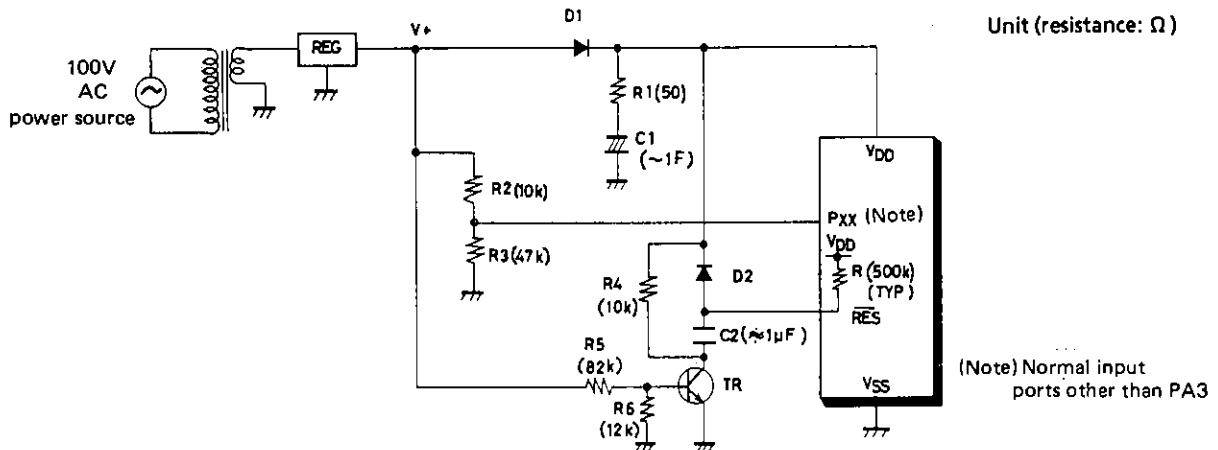

Fig. 2-1. Sample application – (1) where the standby function is used for power failure backup

2-1-2. Operating waveform in sample application circuit – (1)

The operating waveform in the sample application circuit in Fig. 2-1 is shown in Fig. 2-2. The mode is roughly divided as follows: a, Power-ON reset, b, Instantaneous break of main power, C, Return from power failure backup.

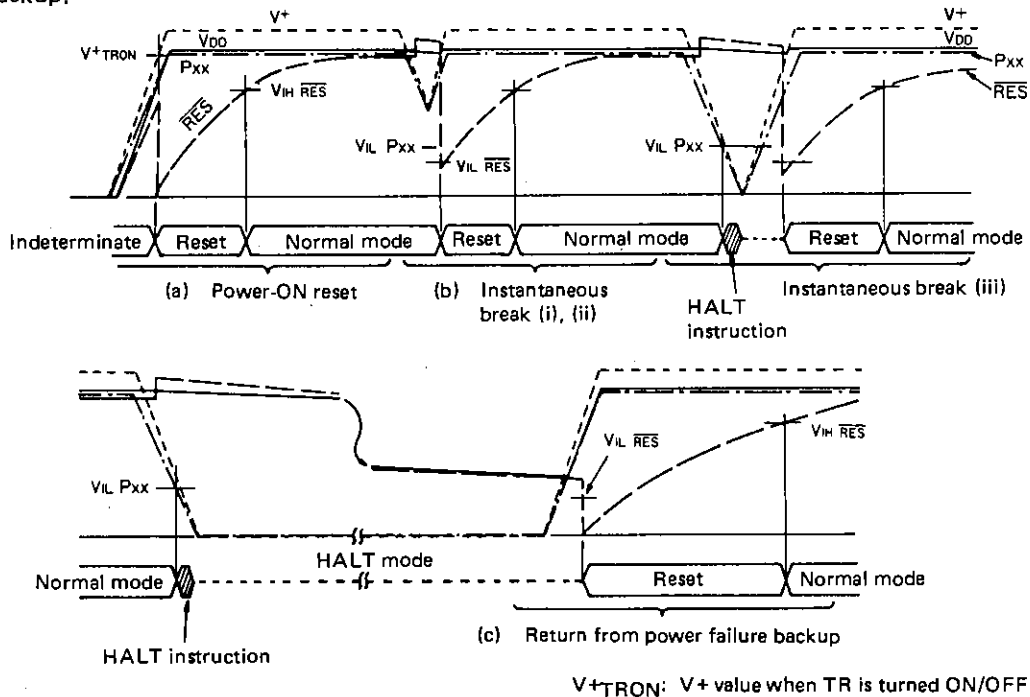

Fig. 2-2. Operating waveforms – (1) in sample application circuit

2-1-3. Operation of sample application circuit — (1)

(a) At the time of power-ON reset

After power rises, a reset occurs automatically and the execution of the program starts at address 000H of the program counter (PC).

— Note —

This sample application circuit provides an indeterminate region where no reset occurs before the operating VDD range is entered.

(b) At the time of instantaneous break

(i) When the PXX input voltage does not meet V_{IL} (The PXX input level does not get lower than input threshold level V_{IL}) and the RES input voltage only meets V_{IL}:
A reset occurs in the normal mode, providing the same operation as power-ON reset.

(ii) When both of the PXX input voltage and RES input voltage do not meet V_{IL}:
The program continues running in the normal mode.

(iii) When both of the PXX input voltage and $\overline{\text{RES}}$ input voltage meet V_{IL}:
When two pollings do not regard the PXX input voltage as "L" level, the HALT mode is not entered and a reset occurs.
When two pollings regard the PXX input voltage as "L" level, the HALT mode is entered and after power is restored a reset occurs, releasing the standby mode.

(c) At the time of return from power failure backup

After power is restored, a reset occurs, releasing the standby mode.

2-1-4. Notes for design of sample application circuit — (1)

● V₊rise time and C₂

Make the time constant (C₂, R) of the reset circuit 10 times as long as the V₊rise time. (R: ON-chip resistor, 500 kohm typ.)

Make the V₊rise time shorter (up to 20 ms).

● R₁ and C₁

Make the R₁ value as small as possible. Make the C₁ value as large as possible according to the backup time calculated, (Fix the R₁ value so that the C₁ charging current does not exceed the power source capacity.)

● R₂ and R₃

Make the "H"-level input voltage applied to the PXX pin equal to V_{DD}.

● R₄

Fix the time constant of C₂ and C₄ so that C₂ can discharge during the period of time from when V₊ gets lower than V₊TR_{OM} (TR OFF) at the time of instantaneous break until the PXX input voltage gets lower than V_{IL} (because release by reset is not available after the HALT mode is entered by instantaneous break).

● R₅ and R₆

Make V₊ (V_{BE} ≅ 0.6V is obtained by R₅ and R₆) when the reset circuit works (Tr ON) more than (operating V_{DD} min + V_F of diode D₁). Observing this note, make V₊ as low as possible to provide a reset early enough after power-ON.

● Backup time

The normal operation continues with a relatively high current dissipation from when power failure is detected by the PXX until the HALT instruction is executed. Fix the C₁ value so that the standby supply voltage is held during backup time of set + above-mentioned time.

2-1-5. Notes for software design

● Design the program so that port A₀ to A₂ cannot be used for standby release and port A₃ is brought to "H" level at the standby mode.

● Input a standby request to a normal input port other than the PA₃ and check by polling this input port twice.

(Example)

```

:
BP1      AAA      ; 1st polling
RCTL     3        ; Interrupt inhibit
BP1      AAA      ; 2nd polling
HALT     ; Standby
AAA:     :
```

2.2. Sample application 2 where the standby function is used for power failure backup

Shown below is a sample application where the program selects between power-ON reset and reset after power is restored.

2-2-1. Sample application circuit – (2) (No instantaneous break in power source)

Fig. 2-3 shows a sample application where the standby function is used for power failure backup.

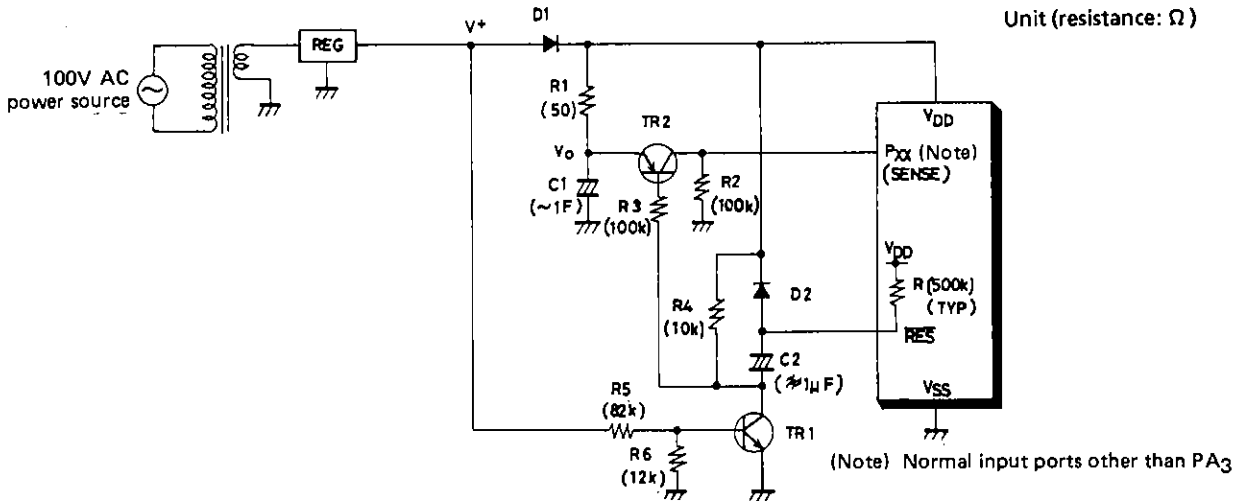

Fig. 2-3 Sample application – (2) where the standby function is used for power failure backup

2-2-2. Operating waveform in sample application circuit – (2)

The operating waveform in the sample application circuit in Fig. 2-3 is shown in Fig. 2-4. The mode is roughly divided as follows: a, Power-ON reset, b. Return from power failure backup.

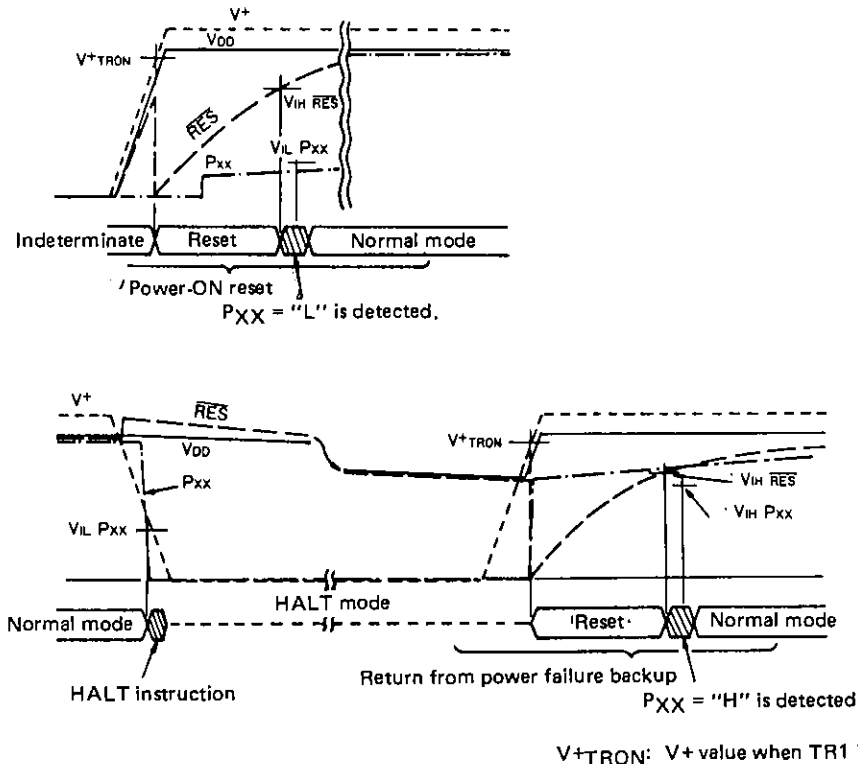

Fig. 2-4. Operating waveform – (2) in sample application circuit

2-2-3. Operation of sample application circuit – (2)

- (a) At the time of power-ON reset
The operation and notes are the same as for sample application circuit – (1), except that after reset release P_{XX} = "L" is program-detected to decide program start after initial reset.
- (b) Standby initiation
When one polling regards the P_{XX} input voltage as "L" level, the HALT mode is entered.
- (c) At the time of return from power failure backup
After power is restored, a reset occurs, releasing the standby mode. After standby release P_{XX} = "H" is program-detected, deciding program start after power is restored.

– Note –

If power is restored after V_{DD} during power failure backup gets lower than V_{IH} on the P_{XX}, P_{XX} = "L" may be program-detected, deciding program start after initial reset.

2-2-4. Notes for design of sample application circuit – (2)

- R₂ and R₃
Fix the R₂ value so that R₂ >> R₁ is yielded and fix the R₃ value so that I_B of TR₂ is limited.
- R₄
There is no severe restriction on the R₄ value, but fix it so that C₂ can discharge quickly.
Other notes are the same as for sample application circuit – (1).

2-2-5. Notes for software design

- Design the program so that port A₀ to A₂ cannot be used for standby release and port A₃ is brought to "H" level.
- Input a standby request to a normal input port other than the PA₃ and check by polling this input port once.

(Example)

```

:
BP1      AAA      ; Polling
HALT     ; Standby
AAA:     :
    
```

2-3. Sample application 3 where the standby function is used for power failure backup

2-3-1. Sample application circuit – (3) (There is an instantaneous break in power source.)

Fig. 2-5. shows a sample application where the standby function is used for power failure backup.

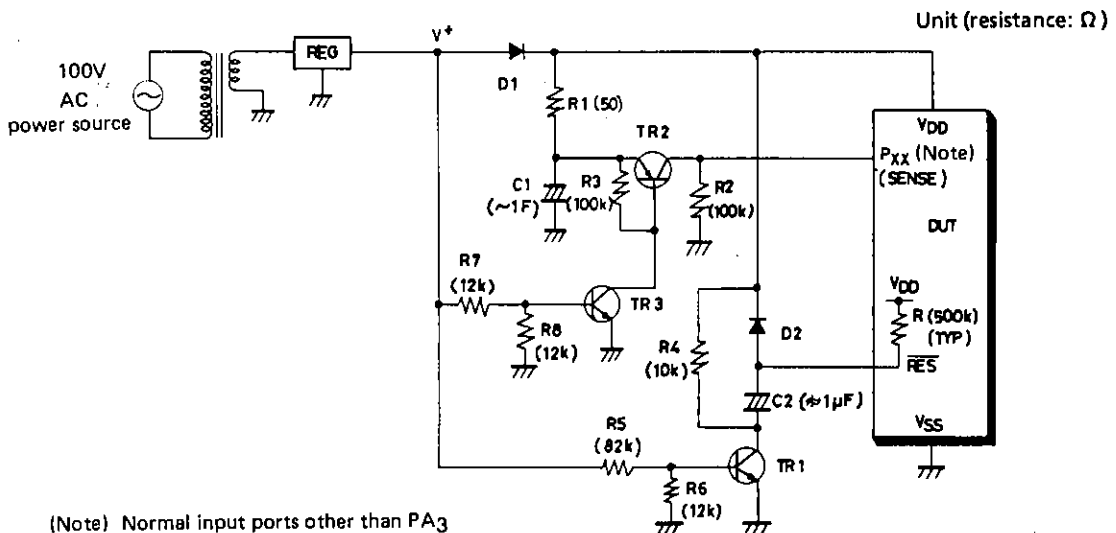

(Note) Normal input ports other than PA₃

Fig. 2-5 Sample application – (3) where the standby function is used for power failure backup

2-3-2. Operating waveform in sample application circuit – (3)

The operating waveform in the sample application circuit in fig. 2-5 is shown in Fig. 2-6. The mode is roughly divided as follows: a, Power-ON reset, b, Instantaneous break of main power, c, Return from power failure backup.

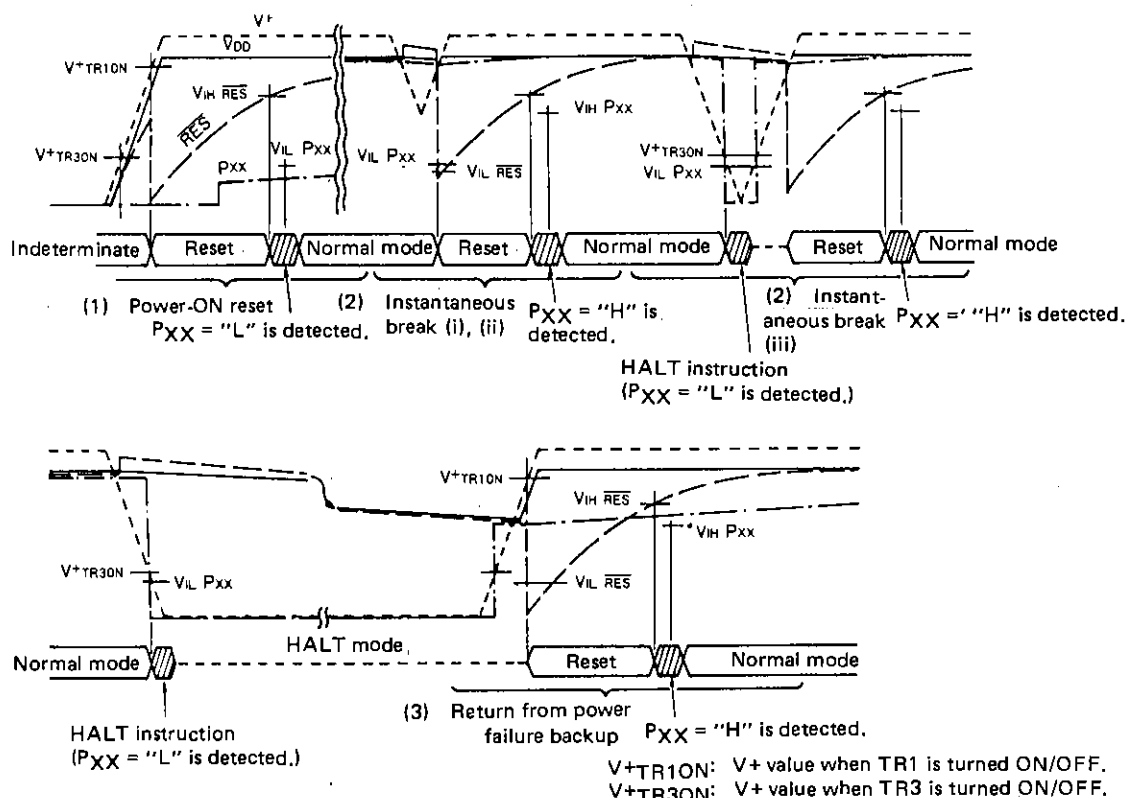

Fig. 2-6. Operating waveform in sample application circuit – (3)

2-3-3. Operation of sample application circuit – (3)

(a) At the time of power-ON reset

The operation and notes are the same as for sample application circuit – (2)

(b) At the time of instantaneous break

(i) When the PXX input voltage does not meet V_{IL} (the PXX input level does not get lower than input threshold level V_{IL}) and the RES input voltage only meets V_{IL}:
A reset occurs in the normal mode. After reset release PXX = "H" is program-detected, deciding program start after instantaneous break.

(ii) When both of the PXX input voltage and RES input voltage do not meet V_{IL}:
The program continues running in the normal mode.

(iii) When both of the PXX input voltage and RES input voltage meet V_{IL}:
When two pollings do not regard the PXX input voltage as "L" level, the HALT mode is not entered and a reset occurs.

When two pollings regard the PXX input voltage as "L" level, the HALT mode is entered and after power is restored, a reset occurs, releasing the standby mode. After standby release PXX = "H" is program-detected, deciding program start after instantaneous break.

(c) At the time of return from power failure backup

The operation and notes are the same as for sample application circuit – (2)

2-3-4. Notes for design of sample application circuit – (3)

- R₃
Bias resistance of TR₂
- R₇ and R₈
Fix the R₇ and R₈ values so that TR₃ is turned ON/OFF at approximately 1.5V of V₊.
Other notes are the same as for sample application circuit – (1)

2-3-5. Notes for software design

Same as for sample application circuit – (1)

2-4. Notes (1) for providing serial transfer

Notes for providing power failure backup and serial transfer

This application assigns top priority to power failure backup. When power failure backup is provided, serial transfer may not be provided normally.

- (1) When the internal clock is used for the serial clock:
Execute the serial transfer start instruction immediately before executing the HALT instruction. If this is done during serial transfer, the power failure backup mode is entered without normal transfer.
- (2) When the external clock is used for the serial clock:
When power failure is detected, it is most prioritized that the HALT mode is entered, providing power failure backup. It is necessary to design an application system where no release signal by serial transfer completion is inputted to the HALT instruction executing cycle and no release signal is inputted during backup.

2-5. Notes (2) for providing serial transfer

Notes for providing HALT and serial transfer for program standby without power failure backup

This application assigns top priority to serial transfer. The following notes for system design must be observed.

- (1) When the internal clock is used for the serial clock:
Transfer starts when it is ready on both sides. When transfer is not ready on the other side, the HALT instruction is executed to reduce the current dissipation. When transfer is ready, the HALT release signal (\overline{RES} , PA) causes return from the standby mode, starting serial transfer.
- (2) When the external clock is used for the serial clock:
Synchronization must be provided between microcomputers to prevent the HALT instruction and HALT release signal (RSIOEND) from overlapping. When transfer is ready, the serial transfer start instruction is executed and the program is placed in the wait state. The other side adjusts time so that no overlap occurs between the HALT instruction and transfer completion and starts serial transfer. On completion of transfer, the HALT mode is released and the program is executed with an instruction immediately following the HALT instruction.

LC6520, LC6522 INSTRUCTION SET

Symbol Description

AC	: Accumulator	M(DP)	: Memory addressed by DP	(),	: Contents
ACt	: Accumulator bit t	P(DP _L)	: Input/output port addressed by DP _L	←	: Transfer and direction
CF	: Carry flag	PC	: Program counter	+	: Addition
CTL	: Control register	STACK	: Stack register	-	: Subtraction
DP	: Data pointer	TM	: Timer	∧	: AND
E	: E register	TMF	: Timer (internal) interrupt request flag	∨	: OR
EXTF	: External interrupt request flag	At, Ma, La	: Working register	⊕	: Exclusive OR
Fn	: Flag bit n	ZF	: Zero flag		
M	: Memory				

Instruction group	Mnemonic	Instruction code		Bytes	Cycles	Function	Description	Status flag affected	Remarks											
		D ₇ D ₆ D ₅ D ₄	D ₃ D ₂ D ₁ D ₀																	
Accumulator manipulation instructions	CLA	Clear AC	1 1 0 0	0 0 0 0	1 1	AC ← 0	The AC contents are cleared.	ZF	* 1											
	CLC	Clear CF	1 1 1 0	0 0 0 1	1 1	CF ← 0	The CF contents are cleared.	CF												
	STC	Set CF	1 1 1 1	0 0 0 1	1 1	CF ← 1	The CF is set.	CF												
	CMA	Complement AC	1 1 1 0	1 0 1 1	1 1	AC ← \overline{AC}	The AC contents are complemented.	ZF												
	INC	Increment AC	0 0 0 0	1 1 1 0	1 1	AC ← (AC) + 1	The AC contents are incremented +1.	ZF CF												
	DEC	Decrement AC	0 0 0 0	1 1 1 1	1 1	AC ← (AC) - 1	The AC contents are decremented -1.	ZF CF												
	RAL	Rotate AC left through CF	0 0 0 0	0 0 0 1	1 1	AC ₀ ← (CF), AC _{n+1} ← (AC _n), CF ← (AC ₃)	The AC contents are shifted left through the CF.	ZF CF												
Memory manipulation instructions	TAE	Transfer AC to E	0 0 0 0	0 0 1 1	1 1	E ← (AC)	The AC contents are transferred to the E.													
	XAE	Exchange AC with E	0 0 0 0	1 1 0 1	1 1	(AC) ↔ (E)	The AC contents and the E contents are exchanged.													
	INM	Increment M	0 0 1 0	1 1 1 0	1 1	M(DP) ← (M(DP)) + 1	The M(DP) contents are incremented +1.	ZF CF												
Arithmetic operation/comparison instructions	DEM	Decrement M	0 0 1 0	1 1 1 1	1 1	M(DP) ← (M(DP)) - 1	The M(DP) contents are decremented -1.	ZF CF												
	SMB bit	Set M data bit	0 0 0 0	1 0 B ₁ B ₀	1 1	M(DP, B ₁ B ₀) ← 1	A single bit of the M(DP) specified with B ₁ B ₀ is set.													
	RMB bit	Reset M data bit	0 0 1 0	1 0 B ₁ B ₀	1 1	M(DP, B ₁ B ₀) ← 0	A single bit of the M(DP) specified with B ₁ B ₀ is reset.	ZF												
	AD	Add M to AC	0 1 1 0	0 0 0 0	1 1	AC ← (AC) + (M(DP))	Binary addition of the AC contents and the M(DP) contents is performed and the result is stored in the AC.	ZF CF												
ADC	Add M to AC with CF	0 0 1 0	0 0 0 0	1 1	AC ← (AC) + (M(DP)) + (CF)	Binary addition of the AC, CF contents and the M(DP) contents is performed and the result is stored in the AC.	ZF CF													
DAA	Decimal adjust AC in addition	1 1 1 0	0 1 1 0	1 1	AC ← (AC) + 6	6 is added to the AC contents.	ZF													
DAS	Decimal adjust AC in subtraction	1 1 1 0	1 0 1 0	1 1	AC ← (AC) + 10	10 is added to the AC contents.	ZF													
EXL	Exclusive or M to AC	1 1 1 1	0 1 0 1	1 1	AC ← (AC) ∨ (M(DP))	The AC contents and the M(DP) contents are exclusive-ORed and the result is stored in the AC.	ZF													
AND	And M to AC	1 1 1 0	0 1 1 1	1 1	AC ← (AC) ∧ (M(DP))	The AC contents and the M(DP) contents are ANDed and the result is stored in the AC.	ZF													
OR	Or M to AC	1 1 1 0	0 1 0 1	1 1	AC ← (AC) ∨ (M(DP))	The AC contents and the M(DP) contents are ORed and the result is stored in the AC.	ZF													
CM	Compare AC with M	1 1 1 1	1 0 1 1	1 1	(M(DP)) + (AC) + 1	The AC contents and the M(DP) contents are compared and the CF and ZF are set/reset. <table border="1" style="margin-left: 20px;"> <tr><th>Comparison result</th><th>CF</th><th>ZF</th></tr> <tr><td>(M(DP)) > (AC)</td><td>0</td><td>0</td></tr> <tr><td>(M(DP)) = (AC)</td><td>1</td><td>1</td></tr> <tr><td>(M(DP)) < (AC)</td><td>1</td><td>0</td></tr> </table>	Comparison result	CF	ZF	(M(DP)) > (AC)	0	0	(M(DP)) = (AC)	1	1	(M(DP)) < (AC)	1	0	ZF CF	
Comparison result	CF	ZF																		
(M(DP)) > (AC)	0	0																		
(M(DP)) = (AC)	1	1																		
(M(DP)) < (AC)	1	0																		
CI data	Compare AC with immediate data	0 0 1 0 0 1 0 0	1 1 0 0 1 3 1 2 1 1 0	2 2	1 3 1 2 1 1 0 + (AC) + 1	The AC contents and the immediate data 1 3 1 2 1 1 0 are compared and the ZF and CF are set/reset. <table border="1" style="margin-left: 20px;"> <tr><th>Comparison result</th><th>CF</th><th>ZF</th></tr> <tr><td>1 3 1 2 1 1 0 > (AC)</td><td>0</td><td>0</td></tr> <tr><td>1 3 1 2 1 1 0 = (AC)</td><td>1</td><td>1</td></tr> <tr><td>1 3 1 2 1 1 0 < (AC)</td><td>1</td><td>0</td></tr> </table>	Comparison result	CF	ZF	1 3 1 2 1 1 0 > (AC)	0	0	1 3 1 2 1 1 0 = (AC)	1	1	1 3 1 2 1 1 0 < (AC)	1	0	ZF CF	
Comparison result	CF	ZF																		
1 3 1 2 1 1 0 > (AC)	0	0																		
1 3 1 2 1 1 0 = (AC)	1	1																		
1 3 1 2 1 1 0 < (AC)	1	0																		
CLI data	Compare DP _L with immediate data	0 0 1 0 0 1 0 1	1 1 0 0 1 3 1 2 1 1 0	2 2	(DP _L) ∨ 1 3 1 2 1 1 0	The DP _L contents and the immediate data 1 3 1 2 1 1 0 are compared.	ZF													
Load/store instructions	LI data	Load AC with immediate data	1 1 0 0	1 3 1 2 1 1 0	1 1	AC ← 1 3 1 2 1 1 0	The immediate data 1 3 1 2 1 1 0 is loaded in the AC.	ZF	* 1											
	S	Store AC to M	0 0 0 0	0 0 1 0	1 1	M(DP) ← (AC)	The AC contents are stored in the M(DP).													
	L	Load AC from M	0 0 1 0	0 0 0 1	1 1	AC ← (M(DP))	The M(DP) contents are loaded in the AC.	ZF												
	XM data	Exchange AC with M, then modify DP _H with immediate data	1 0 1 0	0 M ₂ M ₁ M ₀	1 2	(AC) ↔ (M(DP)) DP _H ← (DP _H) ∨ 0 M ₂ M ₁ M ₀	The AC contents and the M(DP) contents are exchanged and then the DP _H contents are modified with the contents of (DP _H) ∨ 0 M ₂ M ₁ M ₀ .	ZF	The ZF is set/reset according to the result of (DP _H) ∨ 0 M ₂ M ₁ M ₀ .											
	X	Exchange AC with M	1 0 1 0	0 0 0 0	1 2	(AC) ↔ (M(DP))	The AC contents and the M(DP) contents are exchanged.	ZF	The ZF is set/reset according to the DP _H contents at the time of instruction execution.											
	XI	Exchange AC with M, then increment DP _L	1 1 1 1	1 1 1 0	1 2	(AC) ↔ (M(DP)) DP _L ← (DP _L) + 1	The AC contents and the M(DP) contents are exchanged and then the DP _L contents are incremented +1.	ZF	The ZF is set/reset according to the result of (DP _L) + 1.											
	XD	Exchange AC with M, then decrement DP _L	1 1 1 1	1 1 1 1	1 2	(AC) ↔ (M(DP)) DP _L ← (DP _L) - 1	The AC contents and the M(DP) contents are exchanged and then the DP _L contents are decremented -1.	ZF	The ZF is set/reset according to the result of (DP _L) - 1.											
RTBL	Read table data from program ROM	0 1 1 0	0 0 1 1	1 2	AC, E ← ROM (PCh, E, AC)	The contents of ROM addressed by the PC whose low-order 8 bits are replaced with the E and AC contents are loaded in the AC and E.														

LC6520C, 6520H, 6522C, 6522H

Instruction group	Mnemonic	Instruction code		Bytes	Cycles	Function	Description	Status flag affected	Remarks
		D ₇ D ₆ D ₅ D ₄	D ₃ D ₂ D ₁ D ₀						
Data pointer manipulation instructions	LDZ data	Load DPH with Zero and DPL with immediate data respectively	1 0 0 0	13 12 11 10	1	1	DPH ← 0 DPL ← 13 12 11 10	The DPH and DPL are loaded with 0 and the immediate data 13 12 11 10 respectively.	
	LHI data	Load DPH with immediate data	0 1 0 0	13 12 11 10	1	1	DPH ← 13 12 11 10	The DPH is loaded with the immediate data 13 12 11 10.	
	IND	Increment DPL	1 1 1 0	1 1 1 0	1	1	DPL ← (DPL) + 1	The DPL contents are incremented +1.	ZF
	DED	Decrement DPL	1 1 1 0	1 1 1 1	1	1	DPL ← (DPL) - 1	The DPL contents are decremented -1.	ZF
	TAL	Transfer AC to DPL	1 1 1 1	0 1 1 1	1	1	DPL ← (AC)	The AC contents are transferred to the DPL.	
	TLA	Transfer DPL to AC	1 1 1 0	1 0 0 1	1	1	AC ← (DPL)	The DPL contents are transferred to the AC.	ZF
	XAH	Exchange AC with DPH	0 0 1 0	0 0 1 1	1	1	(AC) ↔ (DPH)	The AC contents and the DPH contents are exchanged.	
Working register manipulation instructions	XAt	Exchange AC with working register At	1 1 1 0	11 10	1	1	(AC) ↔ (A0)	The AC contents and the contents of working register At are exchanged. At is assigned one of A0, A1, A2, A3 according to t1 t0.	
	XAO		1 1 1 0	0 0 1 0	1	1	(AC) ↔ (A1)		
	XA1		1 1 1 0	0 1 0 0	1	1	(AC) ↔ (A2)		
	XA2		1 1 1 0	1 0 0 0	1	1	(AC) ↔ (A3)		
	XA3		1 1 1 0	1 1 0 0	1	1	(AC) ↔ (A3)		
	XHa	Exchange DPH with working register Ha	1 1 1 1	a	1	1	(DPH) ↔ (H0)	The DPH contents and the contents of working register Ha are exchanged. Ha is assigned either of H0 or H1 according to a.	
XH1	1 1 1 1		1	1	1	(DPH) ↔ (H1)			
XLa	Exchange DPL with working register La	1 1 1 1	a	1	1	(DPL) ↔ (L0)	The DPL contents and the contents of working register La are exchanged. La is assigned either of L0 or L1 according to a.		
XL1		1 1 1 1	1	1	1	(DPL) ↔ (L1)			
Flag manipulation instructions	SFB flag	Set flag bit	0 1 0 1	B3 B2 B1 B0	1	1	F _n ← 1	The flag specified with B3 B2 B1 B0 is set.	
	RFB flag	Reset flag bit	0 0 0 1	B3 B2 B1 B0	1	1	F _n ← 0	The flag specified with B3 B2 B1 B0 is reset.	ZF
Jump/subroutine instructions	JMP addr	Jump in the current bank	0 1 1 0	1 P10 P9 P8 P7 P6 P5 P4	2	2	PC ← PC11 (if PC11) P10 P9 P8 P7 P6 P5 P4 P3 P2 P1 P0	A jump to the address specified with the PC11 (or PC11) and immediate data P10 P9 P8 P7 P6 P5 P4 P3 P2 P1 P0 occurs.	If the BANK and JMP instructions are executed consecutively, PC11 ← PC11.
	JPEA	Jump in the current page modified by E and AC	1 1 1 1	1 0 1 0	1	1	PC7~0 ← (E, AC)	A jump to the address specified with the contents of the PC whose low-order 8 bits are replaced by the E and AC contents occurs.	
	CZP addr	Call subroutine in the zero page	1 0 1 1	P3 P2 P1 P0	1	1	STACK ← (PC) + 1 PC11~6, PC1~0 ← 0 PC5~2 ← P3 P2 P1 P0	A subroutine in page 0 of bank 0 is called.	
	CAL addr	Call subroutine in the zero bank	1 0 1 0	1 P10 P9 P8 P7 P6 P5 P4	2	2	STACK ← (PC) + 2 PC11~0 ← 0 P10 P9 P8 P7 P6 P5 P4 P3 P2 P1 P0	A subroutine in bank 0 is called.	
	RT	Return from subroutine	0 1 1 0	0 0 1 0	1	1	PC ← (STACK)	A return from a subroutine occurs.	
	RTI	Return from interrupt routine	0 0 1 0	0 0 1 0	1	1	PC ← (STACK) CF ZF ← CSF, ZSF	A return from an interrupt service routine occurs.	ZF CF
	BANK	Change bank	1 1 1 1	1 1 0 1	1	1	PC11 ← (PC11)	The bank is changed.	Effective only when used immediately before the JMP instruction.
Branch instructions	BAI addr	Branch on AC bit	0 1 1 1	0 0 t1 t0	2	2	PC7~0 ← P7 P6 P5 P4 P3 P2 P1 P0 if ACt = 1	If a single bit of the AC specified with the immediate data t1 t0 is 1, a branch to the address specified with the immediate data P7 P6 P5 P4 P3 P2 P1 P0 within the same page occurs.	Mnemonic is BA0 to BA3 according to the value of t.
	BNAI addr	Branch on no AC bit	0 0 1 1	0 0 t1 t0	2	2	PC7~0 ← P7 P6 P5 P4 P3 P2 P1 P0 if ACt = 0	If a single bit of the AC specified with the immediate data t1 t0 is 0, a branch to the address specified with the immediate data P7 P6 P5 P4 P3 P2 P1 P0 within the same page occurs.	Mnemonic is BNA0 to BNA3 according to the value of t.
	BMI addr	Branch on M bit	0 1 1 1	0 1 t1 t0	2	2	PC7~0 ← P7 P6 P5 P4 P3 P2 P1 P0 if (M(DP, t1 t0)) = 1	If a single bit of the M(DP) specified with the immediate data t1 t0 is 1, a branch to the address specified with the immediate data P7 P6 P5 P4 P3 P2 P1 P0 within the same page occurs.	Mnemonic is BM0 to BM3 according to the value of t.
	BNMI addr	Branch on no M bit	0 0 1 1	0 1 t1 t0	2	2	PC7~0 ← P7 P6 P5 P4 P3 P2 P1 P0 if (M(DP, t1 t0)) = 0	If a single bit of the M(DP) specified with the immediate data t1 t0 is 0, a branch to the address specified with the immediate data P7 P6 P5 P4 P3 P2 P1 P0 within the same page occurs.	Mnemonic is BNM0 to BNM3 according to the value of t.
	BPI addr	Branch on Port bit	0 1 1 1	1 0 t1 t0	2	2	PC7~0 ← P7 P6 P5 P4 P3 P2 P1 P0 if (P(DPL, t1 t0)) = 1	If a single bit of port P(DPL) specified with the immediate data t1 t0 is 1, a branch to the address specified with the immediate data P7 P6 P5 P4 P3 P2 P1 P0 within the same page occurs.	Mnemonic is BP0 to BP3 according to the value of t.
	BNPI addr	Branch on no Port bit	0 0 1 1	1 0 t1 t0	2	2	PC7~0 ← P7 P6 P5 P4 P3 P2 P1 P0 if (P(DPL, t1 t0)) = 0	If a single bit of port P(DPL) specified with the immediate data t1 t0 is 0, a branch to the address specified with the immediate data P7 P6 P5 P4 P3 P2 P1 P0 within the same page occurs.	Mnemonic is BNP0 to BNP3 according to the value of t.
	BTM addr	Branch on timer	0 1 1 1	1 1 0 0	2	2	PC7~0 ← P7 P6 P5 P4 P3 P2 P1 P0 if TMF = 1 then TMF ← 0	If the TMF is 1, a branch to the address specified with the immediate data P7 P6 P5 P4 P3 P2 P1 P0 within the same page occurs. The TMF is reset.	TMF

LC6520C, 6520H, 6522C, 6522H

Instruction group	Mnemonic	Instruction code		Bytes	Cycles	Function	Description*	Status flag affected	Remarks	
		D ₇ D ₆ D ₅ D ₄	D ₃ D ₂ D ₁ D ₀							
Branch instructions	BNTM addr	Branch on no timer	0 0 1 1 P ₇ P ₆ P ₅ P ₄	1 1 0 0 P ₃ P ₂ P ₁ P ₀	2	2	PC _{7~0} ← P ₇ P ₆ P ₅ P ₄ P ₃ P ₂ P ₁ P ₀ if TMF = 0 then TMF ← 0	If the TMF is 0, a branch to the address specified with the immediate data P ₇ P ₆ P ₅ P ₄ P ₃ P ₂ P ₁ P ₀ within the same page occurs. The TMF is reset.	TMF	
	BI addr	Branch on interrupt	0 1 1 1 P ₇ P ₆ P ₅ P ₄	1 1 0 1 P ₃ P ₂ P ₁ P ₀	2	2	PC _{7~0} ← P ₇ P ₆ P ₅ P ₄ P ₃ P ₂ P ₁ P ₀ if EXTF = 1 then EXTF ← 0	If the EXTF is 1, a branch to the address specified with the immediate data P ₇ P ₆ P ₅ P ₄ P ₃ P ₂ P ₁ P ₀ within the same page occurs. The EXTF is reset.	EXTF	
	BNI addr	Branch on no interrupt	0 0 1 1 P ₇ P ₆ P ₅ P ₄	1 1 0 1 P ₃ P ₂ P ₁ P ₀	2	2	PC _{7~0} ← P ₇ P ₆ P ₅ P ₄ P ₃ P ₂ P ₁ P ₀ if EXTF = 0 then EXTF ← 0	If the EXTF is 0, a branch to the address specified with the immediate data P ₇ P ₆ P ₅ P ₄ P ₃ P ₂ P ₁ P ₀ within the same page occurs. The EXTF is reset.	EXTF	
	BC addr	Branch on CF	0 1 1 1 P ₇ P ₆ P ₅ P ₄	1 1 1 1 P ₃ P ₂ P ₁ P ₀	2	2	PC _{7~0} ← P ₇ P ₆ P ₅ P ₄ P ₃ P ₂ P ₁ P ₀ if CF = 1	If the CF is 1, a branch to the address specified with the immediate data P ₇ P ₆ P ₅ P ₄ P ₃ P ₂ P ₁ P ₀ within the same page occurs.		
	BNC addr	Branch on no CF	0 0 1 1 P ₇ P ₆ P ₅ P ₄	1 1 1 1 P ₃ P ₂ P ₁ P ₀	2	2	PC _{7~0} ← P ₇ P ₆ P ₅ P ₄ P ₃ P ₂ P ₁ P ₀ if CF = 0	If the CF is 0, a branch to the address specified with the immediate data P ₇ P ₆ P ₅ P ₄ P ₃ P ₂ P ₁ P ₀ within the same page occurs.		
	BZ addr	Branch on ZF	0 1 1 1 P ₇ P ₆ P ₅ P ₄	1 1 1 0 P ₃ P ₂ P ₁ P ₀	2	2	PC _{7~0} ← P ₇ P ₆ P ₅ P ₄ P ₃ P ₂ P ₁ P ₀ if ZF = 1	If the ZF is 1, a branch to the address specified with the immediate data P ₇ P ₆ P ₅ P ₄ P ₃ P ₂ P ₁ P ₀ within the same page occurs.		
	BNZ addr	Branch on no ZF	0 0 1 1 P ₇ P ₆ P ₅ P ₄	1 1 1 0 P ₃ P ₂ P ₁ P ₀	2	2	PC _{7~0} ← P ₇ P ₆ P ₅ P ₄ P ₃ P ₂ P ₁ P ₀ if ZF = 0	If the ZF is 0, a branch to the address specified with the immediate data P ₇ P ₆ P ₅ P ₄ P ₃ P ₂ P ₁ P ₀ within the same page occurs.		
	BF _n addr	Branch on flag bit	1 1 0 1 P ₇ P ₆ P ₅ P ₄	n ₃ n ₂ n ₁ n ₀ P ₃ P ₂ P ₁ P ₀	2	2	PC _{7~0} ← P ₇ P ₆ P ₅ P ₄ P ₃ P ₂ P ₁ P ₀ if F _n = 1	If the flag bit of the 16 flags specified with the immediate data n ₃ n ₂ n ₁ n ₀ is 1, a branch to the address specified with the immediate data P ₇ P ₆ P ₅ P ₄ P ₃ P ₂ P ₁ P ₀ within the same page occurs.		Mnemonic is BFD to BFI5 according to the value of n.
	BNF _n addr	Branch on no flag bit	1 0 0 1 P ₇ P ₆ P ₅ P ₄	n ₃ n ₂ n ₁ n ₀ P ₃ P ₂ P ₁ P ₀	2	2	PC _{7~0} ← P ₇ P ₆ P ₅ P ₄ P ₃ P ₂ P ₁ P ₀ if F _n = 0	If the flag bit of the 16 flags specified with the immediate data n ₃ n ₂ n ₁ n ₀ is 0, a branch to the address specified with the immediate data P ₇ P ₆ P ₅ P ₄ P ₃ P ₂ P ₁ P ₀ within the same page occurs.		Mnemonic is BNF0 to BNF15 according to the value of n.
Input/Output instructions	IP	Input port to AC	0 0 0 0	1 1 0 0	1	1	AC ← (P(DP _L))	Port P(DP _L) contents are loaded in the AC.	ZF	
	OP	Output AC to port	0 1 1 0	0 0 0 1	1	1	P(DP _L) ← (AC)	The AC contents are outputted to port P(DP _L).		
	SPB bit	Set port bit	0 0 0 0	0 1 B ₁ B ₀	1	2	P(DP _L , B ₁ B ₀) ← 1	A single bit in port P(DP _L) specified with the immediate data B ₁ B ₀ is set.		When this instruction is executed, the E contents are destroyed.
	RPB bit	Reset port bit	0 0 1 0	0 1 B ₁ B ₀	1	2	P(DP _L , B ₁ B ₀) ← 0	A single bit in port P(DP _L) specified with the immediate data B ₁ B ₀ is reset.	ZF	When this instruction is executed, the E contents are destroyed.
Other instructions	SCTL bit	Set control register bit(S)	0 0 1 0 1 0 0 0	1 1 0 0 B ₃ B ₂ B ₁ B ₀	2	2	CTL ← (CTL) V B ₃ B ₂ B ₁ B ₀	The bits of the control register specified with the immediate data B ₃ B ₂ B ₁ B ₀ are set.		
	RCTL bit	Reset control register bit(S)	0 0 1 0 1 0 0 1	1 1 0 0 B ₃ B ₂ B ₁ B ₀	2	2	CTL ← (CTL) A B ₃ B ₂ B ₁ B ₀	The bits of the control register specified with the immediate data B ₃ B ₂ B ₁ B ₀ are reset.	ZF	
	WTTM	Write timer	1 1 1 1	1 0 0 1	1	1	TM ← (E), (AC) TMF ← 0	The E and AC contents are loaded in the timer. The TMF is reset.	TMF	
	HALT	Halt	1 1 1 1	0 1 1 0	1	1	Halt	All operations stop.		Only when all pins of port PA are set at L, stop.
	NOP	No operation	0 0 0 0	0 0 0 0	1	1	No operation	No operation is performed, but 1 machine cycle is consumed.		

*1 If the CLA instruction is used consecutively in such a manner as CLA, CLA, -----, the first CLA instruction only is effective and the following CLA instructions are changed to the NOP instructions. This is also true of the LI instruction.

- No products described or contained herein are intended for use in surgical implants, life-support systems, aerospace equipment, nuclear power control systems, vehicles, disaster/crime-prevention equipment and the like, the failure of which may directly or indirectly cause injury, death or property loss.
- Anyone purchasing any products described or contained herein for an above-mentioned use shall:
 - ① Accept full responsibility and indemnify and defend SANYO ELECTRIC CO., LTD., its affiliates, subsidiaries and distributors and all their officers and employees, jointly and severally, against any and all claims and litigation and all damages, cost and expenses associated with such use;
 - ② Not impose any responsibility for any fault or negligence which may be cited in any such claim or litigation on SANYO ELECTRIC CO., LTD., its affiliates, subsidiaries and distributors or any of their officers and employees jointly or severally.
- Information (including circuit diagrams and circuit parameters) herein is for example only; it is not guaranteed for volume production, SANYO believes information herein is accurate and reliable, but no guarantees are made or implied regarding its use or any infringements of intellectual property rights or other rights of third parties.

General purpose transistor (50V, 0.15A)

2SC2412K / 2SC4081 / 2SC4617 / 2SC5658 / 2SC1740S

●Features

- Low Cob.
Cob=2.0pF (Typ.)
- Complements the 2SA1037AK /
2SA1576A / 2SA1774H /
2SA2029 / 2SA933AS.

●Structure

Epitaxial planar type
NPN silicon transistor

●External dimensions (Units : mm)

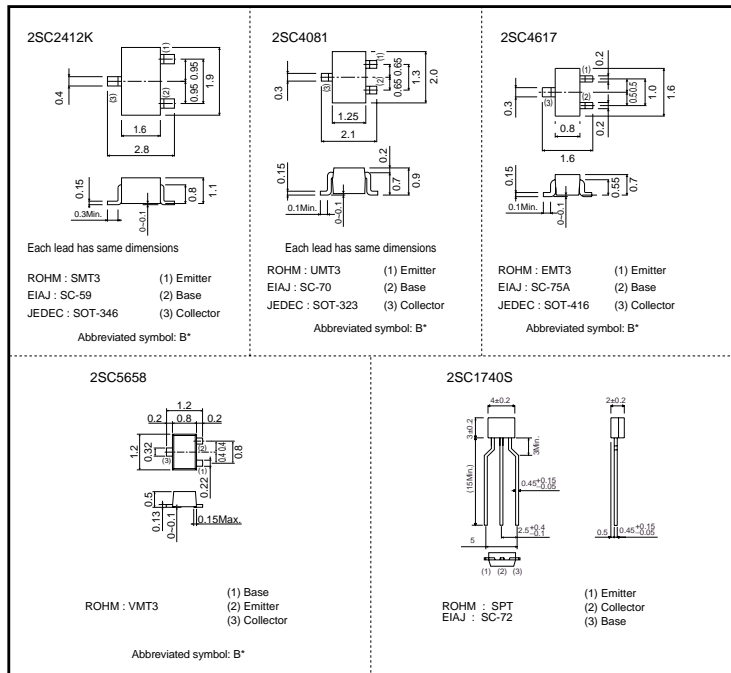

* Denotes hFE

●Absolute maximum (Ta=25°C)

Parameter	Symbol	Limits	Unit
Collector-base voltage	V _{CB0}	60	V
Collector-emitter voltage	V _{CE0}	50	V
Emitter-base voltage	V _{EB0}	7	V
Collector current	I _c	0.15	A
Collector power dissipation	2SC2412K, 2SC4081	0.2	W
	2SC4617, 2SC5658	0.15	
	2SC1740S	0.3	
Junction temperature	T _j	150	°C
Storage temperature	T _{stg}	-55~+150	°C

2SC2412K / 2SC4081 / 2SC4617 /
2SC5658 / 2SC1740S

Transistors

●Electrical characteristics (Ta=25°C)

Parameter	Symbol	Min.	Typ.	Max.	Unit	Conditions
Collector-base breakdown voltage	BV _{CBO}	60	–	–	V	I _c =50μA
Collector-emitter breakdown voltage	BV _{CEO}	50	–	–	V	I _c =1mA
Emitter-base breakdown voltage	BV _{EBO}	7	–	–	V	I _E =50μA
Collector cutoff current	I _{CBO}	–	–	0.1	μA	V _{CB} =60V
Emitter cutoff current	I _{EBO}	–	–	0.1	μA	V _{EB} =7V
DC current transfer ratio	h _{FE}	120	–	560	–	V _{CE} =6V, I _c =1mA
Collector-emitter saturation voltage	V _{CE(sat)}	–	–	0.4	V	I _c /I _B =50mA/5mA
Transition frequency	f _T	–	180	–	MHz	V _{CE} =12V, I _E =–2mA, f=100MHz
Output capacitance	C _{ob}	–	2	3.5	pF	V _{CE} =12V, I _E =0A, f=1MHz

●Packaging specifications and h_{FE}

Type	h _{FE}	Package	Taping				Bulk
		Code	T146	T106	TL	T2L	TP
		Basic ordering unit (pieces)	3000	3000	3000	8000	5000
2SC2412K	QRS	○	–	–	–	–	
2SC4081	QRS	–	○	–	–	–	
2SC4617	QRS	–	–	○	–	–	
2SC5658	QRS	–	–	–	○	–	
2SC1740S	QRS	–	–	–	–	○	

h_{FE} values are classified as follows :

Item	Q	R	S
h _{FE}	120~270	180~390	270~560

●Electrical characteristic curves

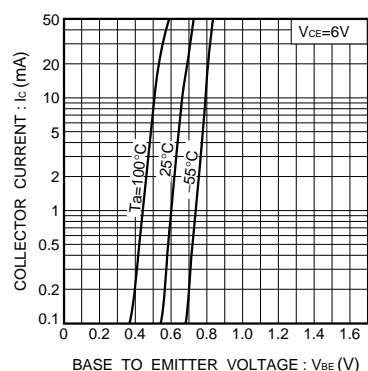

Fig.1 Grounded emitter propagation characteristics

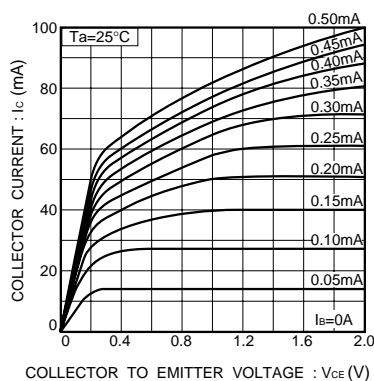

Fig.2 Grounded emitter output characteristics (I)

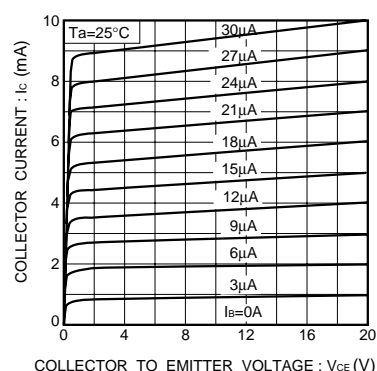

Fig.3 Grounded emitter output characteristics (II)

Transistors

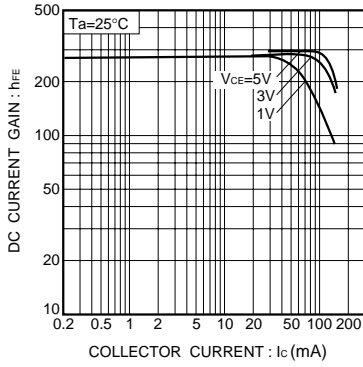

Fig.4 DC current gain vs. collector current (I)

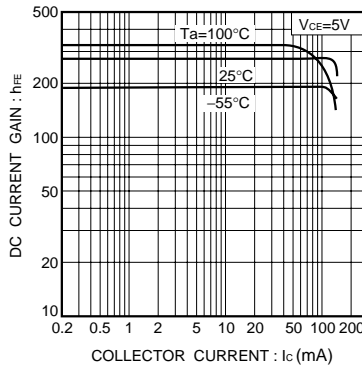

Fig.5 DC current gain vs. collector current (II)

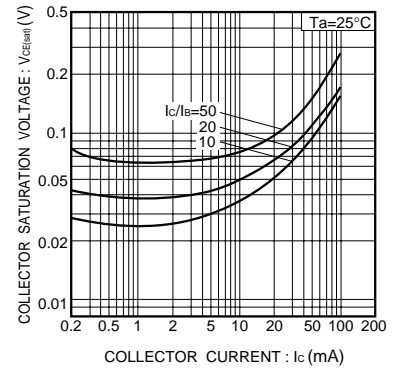

Fig. 6 Collector-emitter saturation voltage vs. collector current

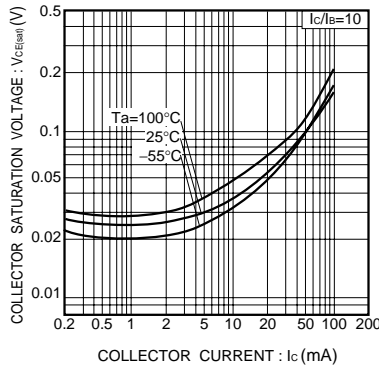

Fig.7 Collector-emitter saturation voltage vs. collector current (I)

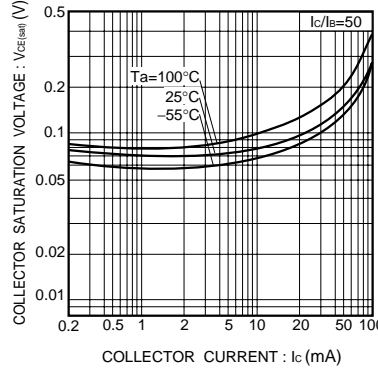

Fig.8 Collector-emitter saturation voltage vs. collector current (II)

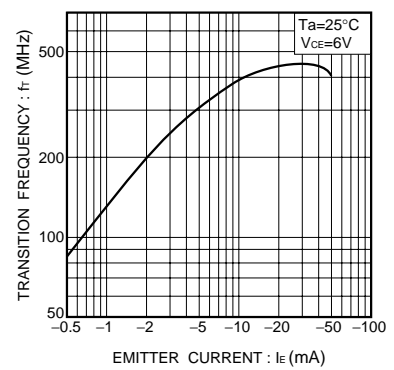

Fig.9 Gain bandwidth product vs. emitter current

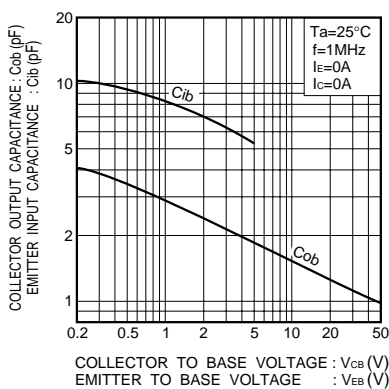

Fig.10 Collector output capacitance vs. collector-base voltage
Emitter input capacitance vs. emitter-base voltage

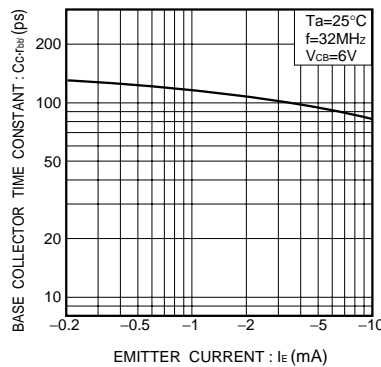

Fig.11 Base-collector time constant vs. emitter current

This datasheet has been download from:

www.datasheetcatalog.com

Datasheets for electronics components.

■ BLOCK DIAGRAM

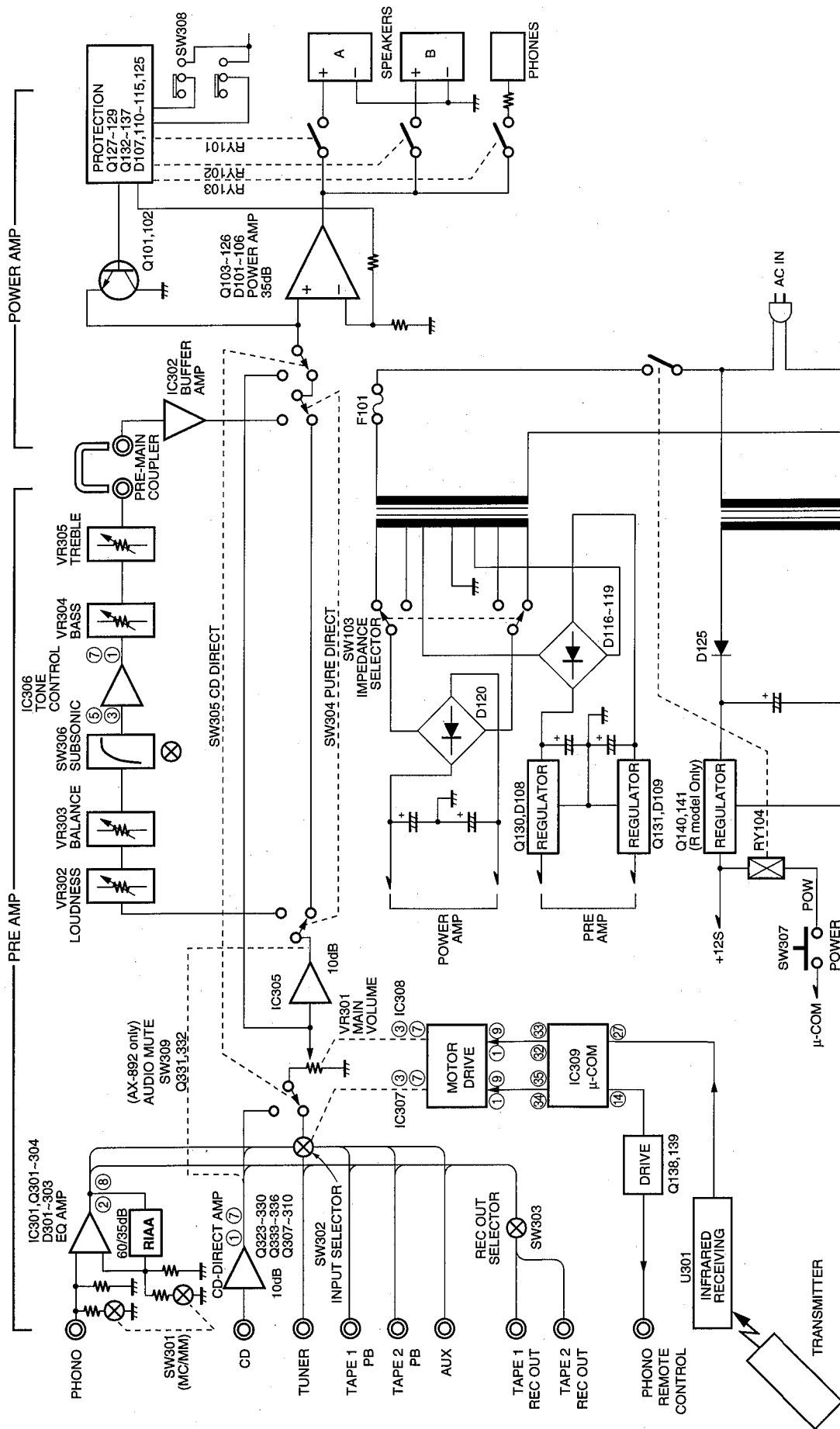

PARTS LIST

■ ELECTRICAL PARTS

■ WARNING

Components having special characteristics are marked \triangle and must be replaced with parts having specifications equal to those originally installed.

- Carbon resistors (1/6W or 1/4W) are not included in the ELECTRICAL PARTS List. For the part Nos. of the carbon resistors, refer to the last page.

ABBREVIATIONS IN THIS LIST ARE AS FOLLOWS:

C. A. EL. CHP	: CHIP ALUMI. ELECTROLYTIC CAP	LED. DSPLY	: LED DISPLAY
C. CE	: CERAMIC CAP	LED. INFRD	: LED, INFRARED
C. CE. ARRAY	: CERAMIC CAP ARRAY	MODUL. RF	: MODULATOR, RF
C. CE. CHP	: CHIP CERAMIC CAP	PHOT. CPL	: PHOTO COUPLER
C. CE. ML	: MULTILAYER CERAMIC CAP	PHOT. INTR	: PHOTO INTERRUPTER
C. CE. M. CHP	: CHIP MULTILAYER CERAMIC CAP	PHOT. RFLCT	: PHOTO REFLECTOR
C. CE. SAFTY	: RECOGNIZED CERAMIC CAP	PIN. TEST	: PIN, TEST POINT
C. CE. TUBLR	: CERAMIC TUBULAR CAP	PLST. RIVET	: PLASTIC RIVET
C. CE. SMI	: SEMI CONDUCTIVE CERAMIC CAP	R. ARRAY	: RESISTOR ARRAY
C. EL	: ELECTROLYTIC CAP	R. CAR	: CARBON RESISTOR
C. MICA	: MICA CAP	R. CAR. CHP	: CHIP RESISTOR
C. ML. FLM	: MULTILAYER FILM CAP	R. CAR.FP	: FLAME PROOF CARBON RESISTOR
C. MP	: METALLIZED PAPER CAP	R. FUS	: FUSABLE RESISTOR
C. MYLAR	: MYLAR FILM CAP	R. MTL. CHP	: CHIP METAL FILM RESISTOR
C. MYLAR. ML	: MULTILAYER MYLAR FILM CAP	R. MTL. FILM	: METAL FILM RESISTOR
C. PAPER	: PAPER CAPACITOR	R. MTL. OXD	: METAL OXIDE FILM RESISTOR
C. PLS	: POLYSTYRENE FILM CAP	R. MTL. PLAT	: METAL PLATE RESISTOR
C. POL	: POLYESTER FILM CAP	RSNR. CE	: CERAMIC RESONATOR
C. POLY	: POLYETHYLENE FILM CAP	RSNR. CRYST	: CRYSTAL RESONATOR
C. PP	: POLYPROPYLENE FILM CAP	R. TW. CEM	: TWIN CEMENT FIXED RESISTOR
C. TNTL	: TANTALUM CAP	R. WW	: WIRE WOUND RESISTOR
C. TNT. CHP	: CHIP TANTALUM CAP	SCR. BND. HD	: BIND HEAD B-TITE SCREW
C. TRIM	: TRIMMER CAP	SCR. BW. HD	: BW HEAD TAPPING SCREW
CN	: CONNECTOR	SCR. CUP	: CUP TITE SCREW
CN. BS. PIN	: CONNECTOR, BASE PIN	SCR. TERM	: SCREW TERMINAL
CN. CANNON	: CONNECTOR, CANNON	SCR. TR	: SCREW, TRANSISTOR
CN. DIN	: CONNECTOR, DIN	SUPRT. PCB	: SUPPORT, P. C. B.
CN. FLAT	: CONNECTOR, FLAT CABLE	SURG. PRTCT	: SURGE PROTECTOR
CN. POST	: CONNECTOR, BASE POST	SW. TACT	: TACT SWITCH
COIL. MX. AM	: COIL, AM MIX	SW. LEAF	: LEAF SWITCH
COIL. AT. FM	: COIL, FM ANTENNA	SW. LEVER	: LEVER SWITCH
COIL. DT. FM	: COIL, FM DETECT	SW. MICRO	: MICRO SWITCH
COIL. MX. FM	: COIL, FM MIX	SW. PUSH	: PUSH SWITCH
COIL. OUTPT	: OUTPUT COIL	SW. RT. ENC	: ROTARY ENCODER
DIOD. ARRAY	: DIODE ARRAY	SW. RT. MTR	: ROTARY SWITCH WITH MOTOR
DIODE. BRG	: DIODE BRIDGE	SW. RT	: ROTARY SWITCH
DIODE. CHP	: CHIP DIODE	SW. SLIDE	: SLIDE SWITCH
DIODE. VAR	: VARACTOR DIODE	TERM. SP	: SPEAKER TERMINAL
DIOD. Z. CHP	: CHIP ZENER DIODE	TERM. WRAP	: WRAPPING TERMINAL
DIODE. ZENR	: ZENER DIODE	THRMST. CHP	: CHIP THERMISTOR
DSCR. CE	: CERAMIC DISCRIMINATOR	TR. CHP	: CHIP TRANSISTOR
FER. BEAD	: FERRITE BEADS	TR. DGT	: DIGITAL TRANSISTOR
FER. CORE	: FERRITE CORE	TR. DGT. CHP	: CHIP DIGITAL TRANSISTOR
FET. CHP	: CHIP FET	TRANS	: TRANSFORMER
FL. DSPLY	: FLUORESCENT DISPLAY	TRANS. PULS	: PULSE TRANSFORMER
FLTR. CE	: CERAMIC FILTER	TRANS. PWR	: POWER TRANSFORMER ASS'y
FLTR. COMB	: COMB FILTER MODULE	TUNER. AM	: TUNER PACK, AM
FLTR. LC. RF	: LC FILTER, EMI	TUNER. FM	: TUNER PACK, FM
GND. MTL	: GROUND PLATE	TUNER. PK	: FRONT-END TUNER PACK
GND. TERM	: GROUND TERMINAL	VR	: ROTARY POTENTIOMETER
HOLDER. FUS	: FUSE HOLDER	VR. MTR	: POTENTIOMETER WITH MOTOR
IC. PRTCT	: IC PROTECTOR	VR. SW	: POTENTIOMETER WITH ROTARY SW
JUMPER. CN	: JUMPER CONNECTOR	VR. SLIDE	: SLIDE POTENTIOMETER
JUMPER. TST	: JUMPER, TEST POINT	VR. TRIM	: TRIMMER POTENTIOMETER
L. DTCT	: LIGHT DETECTING MODULE		
L. EMIT	: LIGHT EMITTING MODULE		

Note) Those parts marked with "#" are not included in the P. C. B. Ass'y.

MAIN P.C.B.

Schm Ref.	PART NO.	Description	
*	VY648300	P.C.B.	MAIN(UC)
*	VY648400	P.C.B.	MAIN(F)
*	VY648500	P.C.B.	MAIN(A)
*	VY648600	P.C.B.	MAIN(B)
*	VY648700	P.C.B.	MAIN(G)
CB101	Vi878500	CN.BS.PIN	7P
CB102	VB858200	CN.BS.PIN	3P
CB103	VS839400	CN.BS.PIN	4P
CB104	VS839500	CN	4P
CB105	VG879900	CN.BS.PIN	2P
CB108	LA002110	TERM.WRAP	2P
CB109	LA002110	TERM.WRAP	2P
CB110	LA002110	TERM.WRAP	2P
CB111	VP206500	HOLDER.FUS	EYF-52BC
CB112	VP206500	HOLDER.FUS	EYF-52BC
CB113	VP206500	HOLDER.FUS	EYF-52BC(G)
CB114	VP206500	HOLDER.FUS	EYF-52BC(G)
CB115	VP206500	HOLDER.FUS	EYF-52BC(R)
CB116	VP206500	HOLDER.FUS	EYF-52BC(R)
C101	VE742700	C.EL	10uF 50V
C102	VE742700	C.EL	10uF 50V
C103	VK533800	C.PP	47pF 200V
C104	VK533800	C.PP	47pF 200V
C105	VP917800	C.PP	1000pF 100V
C106	VP917800	C.PP	1000pF 100V
C107	VG291400	C.EL	220uF 50V
C108	VG291400	C.EL	220uF 50V
C109	FU351220	C.MICA	22pF 500V
C110	FU351220	C.MICA	22pF 500V
C111	VK533900	C.PP	100pF 200V
C112	VK533900	C.PP	100pF 200V
C113	VK533900	C.PP	100pF 200V
C114	VK533900	C.PP	100pF 200V
C115	VE742600	C.EL	47uF 25V
C116	VE742600	C.EL	47uF 25V
C117	VP918300	C.PP	0.022uF 100V
C118	VP918300	C.PP	0.022uF 100V
C119	Vi716700	C.MYLAR	0.01uF 50V(ABG)
C120	Vi716700	C.MYLAR	0.01uF 50V(ABG)
C121	Vi716700	C.MYLAR	0.01uF 50V(ABG)
C122	Vi716700	C.MYLAR	0.01uF 50V(ABG)
C123	VK534100	C.PP	0.01uF 100V(ABG)
C124	VK534100	C.PP	0.01uF 100V(ABG)
C125	Vi377400	C.EL	4.7uF 63V
C126	UJ895220	C.EL	0.22uF 100V
C128	VK534000	C.PP	220pF 200V
C130	VP918500	C.EL	680uF 63V
C131	VP918500	C.EL	680uF 63V
C132	VG287800	C.EL	330uF 16V
C133	VG287800	C.EL	330uF 16V
C134	VG291200	C.EL	47uF 50V
C135	VG291200	C.EL	47uF 50V
C136	VG286900	C.EL	220uF 10V

* New Parts

Schm Ref.	PART NO.	Description	
*	C137	VQ083100	C.EL 100uF 16V
	C138	VJ839000	C.EL 0.47uF 50V
	C139	VG289400	C.EL 3300uF 25V
	C140	VG289400	C.EL 3300uF 25V
	C141	VK574600	C.EL 12000uF 63V
	C142	VK574600	C.EL 12000uF 63V
	C143	VR325400	C.MYLAR 0.1uF 100V
	C144	VR325400	C.MYLAR 0.1uF 100V
	C149	VG290900	C.EL 10uF 50V(R)
	C150	VG290900	C.EL 10uF 50V(R)
	C151	UJ778220	C.EL 220uF 63V(R)
	C151	VG289100	C.EL 330uF 25V(UCABG)
	C152	Vi715500	C.MYLAR 1000pF 50V(UCABG)
	C152	VQ079600	C.MYLAR 1000pF 100V(R)
	C153	VG744000	C.MYLAR.ML 0.15uF 50V
	C154	VG744000	C.MYLAR.ML 0.15uF 50V
	C155	VZ001900	C.MYLAR 0.082uF 50V
	C156	VZ001900	C.MYLAR 0.082uF 50V
	C157	VS741700	C.CE.SAFTY 0.01uF 275V
	C158	FG213100	C.CE 1000pF 50V
	C159	VK534100	C.PP 0.01uF 100V
	C160	UA655100	C.MYLAR 0.1uF 50V
	C162	Vi716700	C.MYLAR 0.01uF 50V(ABG)
	C163	Vi716700	C.MYLAR 0.01uF 50V(ABG)
	C164	VK533900	C.PP 100pF 200V
	C165	VK533900	C.PP 100pF 200V
	C166	VK534000	C.PP 220pF 200V
	C167	VK534000	C.PP 220pF 200V
	C168	Vi716700	C.MYLAR 0.01uF 50V(ABG)
	C169	Vi716700	C.MYLAR 0.01uF 50V(ABG)
	D101	VD631600	DIODE 1SS133,176,HSS104
	D102	VD631600	DIODE 1SS133,176,HSS104
	D103	VD631600	DIODE 1SS133,176,HSS104
	D104	VD631600	DIODE 1SS133,176,HSS104
	D105	VD631600	DIODE 1SS133,176,HSS104
	D106	VD631600	DIODE 1SS133,176,HSS104
	D107	VN008700	DIODE 1SS270A
	D108	VN008700	DIODE 1SS270A
	D109	VD631600	DIODE 1SS133,176,HSS104
	D110	VD631600	DIODE 1SS133,176,HSS104
	D111	VD631600	DIODE 1SS133,176,HSS104
	D112	VD631600	DIODE 1SS133,176,HSS104
	D113	VD631600	DIODE 1SS133,176,HSS104
	D114	VD631600	DIODE 1SS133,176,HSS104
	D115	VD631600	DIODE 1SS133,176,HSS104
	D116	VU264100	DIODE 1SR139-400
	D117	VU264100	DIODE 1SR139-400
	D118	VU264100	DIODE 1SR139-400
	D119	VU264100	DIODE 1SR139-400
	D120	VM702000	DIODE.BRG S5VB20 3.5A 200V
	D121	VG441000	DIODE.ZENR MTZJ16A 16V
	D122	VG441000	DIODE.ZENR MTZJ16A 16V
	D123	VD631600	DIODE 1SS133,176,HSS104

△
△
△
△
△

* New Parts

MAIN P.C.B.

Schm Ref.	PART NO.	Description			Schm Ref.	PART NO.	Description	
	D124	VG440300	DIODE.ZENR	MTZJ12C 12V(R)	△	Q131	VP872600	TR 2SA1708 S,T
	D125	VU264100	DIODE	1SR139-400		Q132	VK432900	TR 2SD1915F S,T
	D126	VN008700	DIODE	1SS270A		Q133	VK432900	TR 2SD1915F S,T
	D127	VG436700	DIODE.ZENR	MTZJ4.3A 4.3V		Q134	VP883100	TR 2SC1890A D,E
△	F101	KB000690	FUSE	T2.5A 250V(ABG)		Q135	VF325300	TR.DGT DTA123ESTP
△	F101	VP909900	FUSE	T7.0A 125V(UCR)		Q136	VF325300	TR.DGT DTA123ESTP
△	F102	KB002980	FUSE	T2.5A 250V(G)		Q138	VF331200	TR.DGT DTC124ES
△	F103	KB000690	FUSE	T2.5A 250V(R)		Q139	VP872600	TR 2SA1708 S,T
△	FR101	VK188200	R.FUS	220Ω 1/4W		Q140	VP768300	TR 2SC4466 O,P,Y(R)
△	FR102	VK188200	R.FUS	220Ω 1/4W		Q141	iC1815C0	TR 2SC1815 Y(R)
	JK102	VJ726800	JACK.MNI		△	R111	VY689500	R.WW 0.22Ω 3W
△	JK103	VT915000	OUTLET.AC	2P(A)	△	R112	VY689500	R.WW 0.22Ω 3W
△	JK103	VU543300	OUTLET.AC	1P(B)	△	R125	HL315100	R.MTL.OXD 100Ω 1W
△	JK103	VV118800	OUTLET.AC	3P(UCR)	△	R126	HL315100	R.MTL.OXD 100Ω 1W
△	* JK103	VV119000	OUTLET.AC	3P(G)	△	R127	HL315100	R.MTL.OXD 100Ω 1W
	L101	VR906600	COIL	0.95uH	△	R128	HL315100	R.MTL.OXD 100Ω 1W
	L102	VR906600	COIL	0.95uH	△	R129	HV456270	R.CAR.FP 2.7KΩ 1/4W
	Q101	VK432900	TR	2SD1915F S,T	△	R130	HV456270	R.CAR.FP 2.7KΩ 1/4W
	Q102	VK432900	TR	2SD1915F S,T	△	R131	HV455820	R.CAR.FP 820Ω 1/4W
	Q103	iA097000	TR	2SA970 GR,BL	△	R132	HV455820	R.CAR.FP 820Ω 1/4W
	Q104	iA097000	TR	2SA970 GR,BL		R133	HV455270	R.CAR.FP 270Ω 1/4W
	Q105	iA097000	TR	2SA970 GR,BL		R134	HV455270	R.CAR.FP 270Ω 1/4W
	Q106	iA097000	TR	2SA970 GR,BL	△	R135	VY689500	R.WW 0.22Ω 3W
	Q107	iC1815C0	TR	2SC1815 Y	△	R136	VY689500	R.WW 0.22Ω 3W
	Q108	iC1815C0	TR	2SC1815 Y	△	R143	HL314100	R.MTL.OXD 10Ω 1W
	Q109	iC1815C0	TR	2SC1815 Y	△	R144	HL314100	R.MTL.OXD 10Ω 1W
	Q110	iC1815C0	TR	2SC1815 Y		R145	HV453470	R.CAR.FP 4.7Ω 1/4W
△	Q111	VE198700	TR	2SA1145 O,Y		R146	HV453470	R.CAR.FP 4.7Ω 1/4W
△	Q112	VE198700	TR	2SA1145 O,Y	△	R151	HL314470	R.MTL.OXD 47Ω 1W
△	Q113	iA101521	TR	2SA1015 Y	△	R152	HL314470	R.MTL.OXD 47Ω 1W
△	Q114	iA101521	TR	2SA1015 Y	△	R154	HL315680	R.MTL.OXD 680Ω 1W
△	Q115	VE198800	TR	2SC2705 O,Y	△	R167	HL315680	R.MTL.OXD 680Ω 1W
△	Q116	VE198800	TR	2SC2705 O,Y	△	R168	HL315680	R.MTL.OXD 680Ω 1W
△	Q117	VK432900	TR	2SD1915F S,T	△	R171	HV453100	R.CAR.FP 1Ω 1/4W
△	Q118	VK432900	TR	2SD1915F S,T	△	R172	HV453100	R.CAR.FP 1Ω 1/4W
△	Q119A	iX603580	TR	2SA1358		R175	HV455680	R.CAR.FP 680Ω 1/4W
△	Q119C	iX603590	TR	2SC3421		R176	HV455680	R.CAR.FP 680Ω 1/4W
△	Q120A	iX603580	TR	2SA1358	△	R177	HL315680	R.MTL.OXD 680Ω 1W
△	Q120C	iX603590	TR	2SC3421	△	R178	HL315680	R.MTL.OXD 680Ω 1W
△ #	Q121A	iX615750	TR	2SA1694 O,P,Y		R181	HL314100	R.MTL.OXD 10Ω 1W
△ #	Q121C	iX615760	TR	2SC4467 O,P,Y		R187	VP939700	R.MTL.FLM 4.7Ω 1W
△ #	Q122A	iX615750	TR	2SA1694 O,P,Y		R188	VP939700	R.MTL.FLM 4.7Ω 1W
△ #	Q122C	iX615760	TR	2SC4467 O,P,Y		R189	VP939700	R.MTL.FLM 4.7Ω 1W
△ #	Q123A	iX615750	TR	2SA1694 O,P,Y		R190	VP939700	R.MTL.FLM 4.7Ω 1W
△ #	Q123C	iX615760	TR	2SC4467 O,P,Y		R191	VP939700	R.MTL.FLM 4.7Ω 1W
△ #	Q124A	iX615750	TR	2SA1694 O,P,Y		R192	VP939700	R.MTL.FLM 4.7Ω 1W
△ #	Q124C	iX615760	TR	2SC4467 O,P,Y		R193	VP939700	R.MTL.FLM 4.7Ω 1W
△	Q125	VP883000	TR	2SA893A D,E		R194	VP939700	R.MTL.FLM 4.7Ω 1W
△	Q126	VP883000	TR	2SA893A D,E	△	R197	HL315560	R.MTL.OXD 560Ω 1W
	Q127	VP883100	TR	2SC1890A D,E	△	R198	HL315560	R.MTL.OXD 560Ω 1W
	Q128	VP883100	TR	2SC1890A D,E		R207	VP939700	R.MTL.FLM 4.7Ω 1W(ABG)
	Q129	VP883000	TR	2SA893A D,E		R208	VP939700	R.MTL.FLM 4.7Ω 1W(ABG)
△	Q130	VP872700	TR	2SC4488 S,T	△	R209	VY689500	R.WW 0.22Ω 3W

* New Parts

* New Parts

MAIN P.C.B. & FUNCTION P. C. B.

Schm Ref.	PART NO.	Description	
△	R210	VY689500	R.WW 0.22Ω 3W
△	R213	VY689500	R.WW 0.22Ω 3W
△	R214	VY689500	R.WW 0.22Ω 3W
△	RY101	VY868200	RELAY DC DH24D2-OT/M-S
△	RY102	VK438300	RELAY DH24D2-OT/M2
△	RY103	VU566700	RELAY DG24D2-OS/M
△	RY104	VU398500	RELAY DCLK1AF12V(UCABG)
△	RY104	VY735300	RELAY DC G5P-1(R)
	SW101	VV523800	SW.SLIDE SL13B-022-BMC1
△	SW102	VA961800	VOLT.SELCT ESE-37247-F(R)
△	T101	XC082A00	TRANS.PWR (R)
△	T101	XQ485B00	TRANS.PWR (UC)
△	T101	XQ486B00	TRANS.PWR (ABG)
	TE101	VF018400	TERM.SP 4P(UCRA)
	TE101	VY696400	TERM.SP 4P CJ9041-06-(BG)
*	TE102	VV247600	TERM.SP 2P
*	TE103	VV247600	TERM.SP 2P
		BB071360	SCR.TERM 8.3x13
		BB070700	GND.MTL
*		VY672600	PLATE.GND SP(ABG)
*	VY648000	P.C.B.	FUNCTION(UC)
*	VY648100	P.C.B.	FUNCTION(RABG)
	CB301	Vi878900	CN.BS.PIN 11P
	CB302	VK025500	CN.BS.PIN 11P
	CB303	Vi878600	CN.BS.PIN 8P
	CB304	VK025200	CN.BS.PIN 8P
	CB305	Vi878500	CN.BS.PIN 7P
	CB306	Vi878500	CN.BS.PIN 7P
	CB307	Vi878500	CN.BS.PIN 7P
	CB308	VK025100	CN.BS.PIN 7P
	CB309	VK026600	CN.BS.PIN 7P
	CB310	VB858700	CN.BS.PIN 8P
	CB312	LB919070	CN.BS.PIN 7P
	CB314	VB858200	CN.BS.PIN 3P
	CB315	VB858100	CN.BS.PIN 2P
	CB316	Vi878100	CN.BS.PIN 3P
	CB317	Vi878100	CN.BS.PIN 3P
	C303	Vi716700	C.MYLAR 0.01uF 50V
	C304	Vi716700	C.MYLAR 0.01uF 50V
	C305	VG290300	C.EL 0.47uF 50V
	C306	VG290300	C.EL 0.47uF 50V
	C307	VQ462600	C.MYLAR 220pF 50V
	C308	VQ462600	C.MYLAR 220pF 50V
	C309	UA652100	C.MYLAR 100pF 50V(RABG)
	C310	UA652100	C.MYLAR 100pF 50V(RABG)
	C311	UA653330	C.MYLAR 3300pF 50V
	C312	UA653330	C.MYLAR 3300pF 50V
	C313	Vi460900	C.EL 2200uF 6.3V
	C314	Vi460900	C.EL 2200uF 6.3V
	C315	UA654330	C.MYLAR 0.033uF 50V

* New Parts

Schm Ref.	PART NO.	Description	
	C316	UA654330	C.MYLAR 0.033uF 50V
	C317	UA653910	C.MYLAR 9100pF 50V
	C318	UA653910	C.MYLAR 9100pF 50V
	C319	VG290900	C.EL 10uF 50V
	C320	VG290900	C.EL 10uF 50V
	C321	Vi715900	C.MYLAR 2200pF 50V
	C322	Vi715900	C.MYLAR 2200pF 50V
	C323	VG287800	C.EL 330uF 16V
	C324	VG287800	C.EL 330uF 16V
	C325	VG291000	C.EL 22uF 50V
	C326	UA655100	C.MYLAR 0.1uF 50V
	C327	VK533900	C.PP 100pF 200V
	C328	VK533900	C.PP 100pF 200V
	C329	VQ645600	C.MYLAR 100pF 50V
	C330	VQ645600	C.MYLAR 100pF 50V
	C331	VQ645600	C.MYLAR 100pF 50V
	C332	VQ645600	C.MYLAR 100pF 50V
	C333	Vi715100	C.MYLAR 470pF 50V
	C334	Vi715100	C.MYLAR 470pF 50V
	C335	VG278400	C.CE.TUBLR 220pF 50V
	C336	VG278400	C.CE.TUBLR 220pF 50V
	C337	VG278400	C.CE.TUBLR 220pF 50V
	C338	VG278400	C.CE.TUBLR 220pF 50V
	C339	VQ645600	C.MYLAR 100pF 50V
	C340	VQ645600	C.MYLAR 100pF 50V
	C341	VF466800	C.CE.TUBLR 100pF 50V
	C342	VF466800	C.CE.TUBLR 100pF 50V
	C343	VG722100	C.EL 1uF 50V
	C344	UA655100	C.MYLAR 0.1uF 50V
	C345	VK533800	C.PP 47pF 200V
	C346	VK533800	C.PP 47pF 200V
	C347	VF466800	C.CE.TUBLR 100pF 50V
	C348	VF466800	C.CE.TUBLR 100pF 50V
	C349	FU451470	C.MICA 47pF 500V
	C350	FU451470	C.MICA 47pF 500V
	C351	VF466800	C.CE.TUBLR 100pF 50V
	C352	VF466800	C.CE.TUBLR 100pF 50V
	C353	UA655100	C.MYLAR 0.1uF 50V
	C354	Vi716700	C.MYLAR 0.01uF 50V(RABG)
	C355	VK533800	C.PP 47pF 200V
	C356	VK533800	C.PP 47pF 200V
	C357	Vi377400	C.EL 4.7uF 63V
	C358	Vi377400	C.EL 4.7uF 63V
	C359	VG287100	C.EL 470uF 10V
	C360	VG287100	C.EL 470uF 10V
	C361	Vi377400	C.EL 4.7uF 63V
	C362	Vi377400	C.EL 4.7uF 63V
	C363	UA653220	C.MYLAR 2200pF 50V
	C364	UA653220	C.MYLAR 2200pF 50V
	C365	VG288000	C.EL 1000uF 16V
	C366	VG288000	C.EL 1000uF 16V
	C367	UA653220	C.MYLAR 2200pF 50V
	C368	UA653220	C.MYLAR 2200pF 50V

* New Parts

FUNCTION P.C.B.

Schm Ref.	PART NO.	Description		
C369	VG290900	C.EL	10uF	50V
C370	VG290900	C.EL	10uF	50V
C371	VG286400	C.EL	330uF	6.3V
C372	VG286400	C.EL	330uF	6.3V
C373	VG288900	C.EL	100uF	25V
C374	VG288900	C.EL	100uF	25V
C375	UA654560	C.MYLAR	0.056uF	50V
C376	UA654560	C.MYLAR	0.056uF	50V
C377	VG278900	C.CE.TUBLR	680pF	50V
C378	VG278900	C.CE.TUBLR	680pF	50V
C379	UA654470	C.MYLAR	0.047uF	50V
C380	UA654470	C.MYLAR	0.047uF	50V
C381	UA654680	C.MYLAR	0.068uF	50V
C382	UA654680	C.MYLAR	0.068uF	50V
C383	UA654680	C.MYLAR	0.068uF	50V
C384	UA654680	C.MYLAR	0.068uF	50V
C385	VG290300	C.EL	0.47uF	50V
C386	VG290300	C.EL	0.47uF	50V
C387	VG278400	C.CE.TUBLR	220pF	50V
C388	VG278400	C.CE.TUBLR	220pF	50V
C389	Vi377400	C.EL	4.7uF	63V
C390	Vi377400	C.EL	4.7uF	63V
C391	VF466700	C.CE.TUBLR	47pF	50V
C392	VF466700	C.CE.TUBLR	47pF	50V
C393	VG291200	C.EL	47uF	50V
C394	VG291200	C.EL	47uF	50V
C395	UA655120	C.MYLAR	0.12uF	50V
C396	UA655120	C.MYLAR	0.12uF	50V
C399	UA654330	C.MYLAR	0.033uF	50V
C400	UA654330	C.MYLAR	0.033uF	50V
C401	VG288900	C.EL	100uF	25V
C402	VG288900	C.EL	100uF	25V
C403	UA654100	C.MYLAR	0.01uF	50V(RABG)
C404	UA654100	C.MYLAR	0.01uF	50V(RABG)
C405	VF760000	C.EL	100uF	10V
C406	VF760000	C.EL	100uF	10V
C407	VG290900	C.EL	10uF	50V
C408	VG290900	C.EL	10uF	50V
C409	VG287100	C.EL	470uF	10V
C410	VG291200	C.EL	47uF	50V
C411	VT180400	C.EL	4700uF	5.5V
C412	VH053100	C.CE.TUBLR	0.1uF	50V
C413	VG290900	C.EL	10uF	50V
C414	VG290500	C.EL	1uF	50V
C415	VH053100	C.CE.TUBLR	0.1uF	50V
C416	VG289100	C.EL	330uF	25V
C417	VH053100	C.CE.TUBLR	0.1uF	50V
C418	VG291200	C.EL	47uF	50V
C420	UM049220	C.EL	2200uF	16V
C421	UM049220	C.EL	2200uF	16V
* C423	VQ083100	C.EL	100uF	16V
* C424	VQ083100	C.EL	100uF	16V
C425	VE021900	C.EL	4.7uF	100V

* New Parts

Schm Ref.	PART NO.	Description		
C426	VE021900	C.EL	4.7uF	100V
C430	Vi377400	C.EL	4.7uF	63V
C431	UA655120	C.MYLAR	0.12uF	50V
C432	UA655120	C.MYLAR	0.12uF	50V
C433	UA655100	C.MYLAR	0.1uF	50V
C434	VH053100	C.CE.TUBLR	0.1uF	50V
C435	VF467100	C.CE.TUBLR	4700pF	16V
C436	VF467100	C.CE.TUBLR	4700pF	16V
D301	VD631600	DIODE	1SS133,176,HSS104	
D302	VD631600	DIODE	1SS133,176,HSS104	
D303	VG437800	DIODE.ZENR	MTZJ5.6C	5.6V
D304	VG435800	DIODE.ZENR	MTZJ3.0A	3.0V
D305	VG437000	DIODE.ZENR	MTZJ4.7A	4.7V
D306	VD631600	DIODE	1SS133,176,HSS104	
D307	VD631600	DIODE	1SS133,176,HSS104	
D308	VD631600	DIODE	1SS133,176,HSS104	
D309	VD631600	DIODE	1SS133,176,HSS104	
D310	VG438100	DIODE.ZENR	MTZJ6.2C	6.2V
D311	VD631600	DIODE	1SS133,176,HSS104	
D312	VD631600	DIODE	1SS133,176,HSS104	
D313	VG437800	DIODE.ZENR	MTZJ5.6C	5.6V
D314	VD631600	DIODE	1SS133,176,HSS104	
D315	VD631600	DIODE	1SS133,176,HSS104	
D316	VR711500	LED(or)	SLR-325DC	
D317	VR711500	LED(or)	SLR-325DC	
D318	VR711500	LED(or)	SLR-325DC	
D319	VD631600	DIODE	1SS133,176,HSS104	
D320	VD631600	DIODE	1SS133,176,(RABG)	
D321	VD631600	DIODE	1SS133,176,(RABG)	
D322	VS132300	LED(re)	SLR-325VCT31	
IC301	XB247301	IC	uPC4570HA	
IC302	XQ212A00	IC	NJM4558LD	
IC305	XM356A00	IC	NJM2068LD	
IC306	XM356A00	IC	NJM2068LD	
IC307	XF557A00	IC	TA7291S	
IC308	XF557A00	IC	TA7291S	
* IC309	XS966A00	IC	LC6520H-4J33 CPU	
JK301	VS899700	JACK.PHONE	JY-6317-02-030	
L301	VF541100	COIL	15uH(RABG)	
L302	VF541100	COIL	15uH(RABG)	
L303	VB056900	COIL	220uH(RABG)	
L304	VB056900	COIL	220uH(RABG)	
L305	Vi543300	COIL	1.0uH	
* PJ301	VV377000	JACK.PIN	2P	
* PJ302	VV248000	JACK.PIN	2P	
PJ303	VV306900	JACK.PIN	4P	
PJ304	VV306900	JACK.PIN	4P	
PJ305	VV306900	JACK.PIN	4P	
PJ306	VV306900	JACK.PIN	4P	
Q301	iA097000	TR	2SA970 GR,BL	
Q302	iA097000	TR	2SA970 GR,BL	
Q303	iA097000	TR	2SA970 GR,BL	
Q304	iA097000	TR	2SA970 GR,BL	

* New Parts

FUNCTION P.C.B.

Schm Ref.	PART NO.	Description	
Q305	VK432900	TR	2SD1915F S,T
Q306	VK432900	TR	2SD1915F S,T
Q307	VK432900	TR	2SD1915F S,T
Q308	VK432900	TR	2SD1915F S,T
Q309	VG721700	TR.DGT	DTA144ES
Q310	VD678700	TR.DGT	DTC114ES
Q311	VD678700	TR.DGT	DTC114ES
Q312	VD678700	TR.DGT	DTC114ES
Q313	iC174020	TR	2SC1740S R,S
Q314	VG721700	TR.DGT	DTA144ES
Q315	iA093320	TR	2SA933S Q,R
Q316	VP883100	TR	2SC1890A D,E
Q317	VG721700	TR.DGT	DTA144ES
Q318	iC174020	TR	2SC1740S R,S
Q319	VG722000	TR.DGT	DTC144ES
Q320	iA093320	TR	2SA933S Q,R
Q321	VP883100	TR	2SC1890A D,E
Q322	iC224030	TR	2SC2240 GR,BL
Q323	iC174020	TR	2SC1740S R,S
Q324	iC174020	TR	2SC1740S R,S
Q325	iA093320	TR	2SA933S Q,R
Q326	iA093320	TR	2SA933S Q,R
Q327	iA093320	TR	2SA933S Q,R
Q328	iA093320	TR	2SA933S Q,R
Q329	iC174020	TR	2SC1740S R,S
Q330	iC174020	TR	2SC1740S R,S
Q333	iC174020	TR	2SC1740S R,S
Q334	iC174020	TR	2SC1740S R,S
Q335	iA093320	TR	2SA933S Q,R
Q336	iA093320	TR	2SA933S Q,R
Q337	VP883100	TR	2SC1890A D,E
R358	HL315100	R.MTL.OXD	100Ω 1W
R359	HL315100	R.MTL.OXD	100Ω 1W
R478	HV453470	R.CAR.FP	4.7Ω 1/4W
SW301	VK333500	SW.PUSH	SPUN19
SW302	VS892300	SW.RT	SRBAA46
SW303	VT021200	SW.RT	RS003-A046BHN-20F4
* SW304	VV399900	SW.PUSH	SPUN12
* SW305	VV399800	SW.PUSH	SPUN12
SW306	VJ850300	SW.PUSH	PSEOYP-CF2KX
* SW307	VV496200	SW.PUSH	PS-9A2-022-18A(UC)
* SW307	VV496300	SW.PUSH	PS-9A2-022-(RABG)
SW308	VV523900	SW.PUSH	PBS-YM-001
U301	VU591000	L.DTCT	GP1U271X
* VR301	VV856800	VR.MTR	A200KΩ
VR302	VP700700	VR	A100KΩ
VR303	VP742000	VR	MN100KΩ
VR304	VP741800	VR	B20KΩ
VR305	VP741900	VR	G25KΩ
XL301	VE906000	RSNR.CE	4MHz
	VJ828000	PIN	IMSA-6024-03E
	BB071360	SCR.TERM	8.3x13
	AA626100	PLATE	25

* New Parts

AX-892

MAIN P.C.B.

Schm Ref.	PART NO.	Description	
*	VY651600	P.C.B.	MAIN(R)
*	VY651700	P.C.B.	MAIN(G)
CB101	Vi878500	CN.BS.PIN	7P
CB102	VB858200	CN.BS.PIN	3P
CB103	VS839400	CN.BS.PIN	4P
CB104	VS839500	CN	4P
CB105	VG879900	CN.BS.PIN	2P
CB106	VQ585000	CN.BS.PIN	8P
CB107	VQ585000	CN.BS.PIN	8P
CB108	LA002110	TERM.WRAP	2P
CB109	LA002110	TERM.WRAP	2P
CB110	LA002110	TERM.WRAP	2P
CB111	VP206500	HOLDER.FUS	EYF-52BC
CB112	VP206500	HOLDER.FUS	EYF-52BC
CB113	VP206500	HOLDER.FUS	EYF-52BC(G)
CB114	VP206500	HOLDER.FUS	EYF-52BC(G)
CB115	VP206500	HOLDER.FUS	EYF-52BC(R)
CB116	VP206500	HOLDER.FUS	EYF-52BC(R)
C101	VE742700	C.EL	10uF 50V
C102	VE742700	C.EL	10uF 50V
C103	VK533800	C.PP	47pF 200V
C104	VK533800	C.PP	47pF 200V
C105	VP917800	C.PP	1000pF 100V
C106	VP917800	C.PP	1000pF 100V
C107	VG291400	C.EL	220uF 50V
C108	VG291400	C.EL	220uF 50V
C109	FU351220	C.MICA	22pF 500V
C110	FU351220	C.MICA	22pF 500V
C111	VK533900	C.PP	100pF 200V
C112	VK533900	C.PP	100pF 200V
C113	VK533900	C.PP	100pF 200V
C114	VK533900	C.PP	100pF 200V
C115	VE742600	C.EL	47uF 25V
C116	VE742600	C.EL	47uF 25V
C117	VP918300	C.PP	0.022uF 100V
C118	VP918300	C.PP	0.022uF 100V
C119	Vi716700	C.MYLAR	0.01uF 50V(G)
C120	Vi716700	C.MYLAR	0.01uF 50V(G)
C123	VK534100	C.PP	0.01uF 100V(G)
C124	VK534100	C.PP	0.01uF 100V(G)
C125	Vi377400	C.EL	4.7uF 63V
C126	UJ895220	C.EL	0.22uF 100V
C128	VK534000	C.PP	220pF 200V
C130	VY804700	C.EL	1000uF 63V
C131	VY804700	C.EL	1000uF 63V
C132	VG287800	C.EL	330uF 16V
C133	VG287800	C.EL	330uF 16V
C134	VG291200	C.EL	47uF 50V
C135	VG291200	C.EL	47uF 50V
C136	VG286900	C.EL	220uF 10V
* C137	VQ083100	C.EL	100uF 16V
C138	VJ839000	C.EL	0.47uF 50V
C139	VG289400	C.EL	3300uF 25V

* New Parts

Schm Ref.	PART NO.	Description	
C140	VG289400	C.EL	3300uF 25V
* C141	VU594100	C.EL	18000uF 63V
* C142	VU594100	C.EL	18000uF 63V
C143	VR325400	C.MYLAR	0.1uF 100V
C144	VR325400	C.MYLAR	0.1uF 100V
C145	Vi716700	C.MYLAR	0.01uF 50V(G)
C146	Vi716700	C.MYLAR	0.01uF 50V(G)
C147	Vi716700	C.MYLAR	0.01uF 50V(G)
C148	Vi716700	C.MYLAR	0.01uF 50V(G)
C149	VG290900	C.EL	10uF 50V(R)
C150	VG290900	C.EL	10uF 50V(R)
C151	UJ778220	C.EL	220uF 63V(R)
C151	VG289100	C.EL	330uF 25V(G)
C152	Vi715500	C.MYLAR	1000pF 50V(G)
C152	VQ079600	C.MYLAR	1000pF 100V(R)
C153	VG744000	C.MYLAR.ML	0.15uF 50V
C154	VG744000	C.MYLAR.ML	0.15uF 50V
C155	VZ001900	C.MYLAR	0.0820uF 50V
C156	VZ001900	C.MYLAR	0.0820uF 50V
C157	VS741700	C.CE.SAFTY	0.01uF 275V
C158	FG213100	C.CE	1000pF 50V
C159	VK534100	C.PP	0.01uF 100V
C160	UA655100	C.MYLAR	0.1uF 50V
C161	UA655100	C.MYLAR	0.1uF 50V
C162	Vi716700	C.MYLAR	0.01uF 50V(G)
C163	Vi716700	C.MYLAR	0.01uF 50V(G)
C164	VK533900	C.PP	100pF 200V
C165	VK533900	C.PP	100pF 200V
C166	VK534000	C.PP	220pF 200V
C167	VK534000	C.PP	220pF 200V
D101	VD631600	DIODE	1SS133,176,HSS104
D102	VD631600	DIODE	1SS133,176,HSS104
D103	VD631600	DIODE	1SS133,176,HSS104
D104	VD631600	DIODE	1SS133,176,HSS104
D105	VD631600	DIODE	1SS133,176,HSS104
D106	VD631600	DIODE	1SS133,176,HSS104
D107	VN008700	DIODE	1SS270A
D108	VN008700	DIODE	1SS270A
D109	VD631600	DIODE	1SS133,176,HSS104
D110	VD631600	DIODE	1SS133,176,HSS104
D111	VD631600	DIODE	1SS133,176,HSS104
D112	VD631600	DIODE	1SS133,176,HSS104
D113	VD631600	DIODE	1SS133,176,HSS104
D114	VD631600	DIODE	1SS133,176,HSS104
D115	VD631600	DIODE	1SS133,176,HSS104
△ D116	VU264100	DIODE	1SR139-400
△ D117	VU264100	DIODE	1SR139-400
△ D118	VU264100	DIODE	1SR139-400
△ D119	VU264100	DIODE	1SR139-400
D120	VM702000	DIODE.BRG	S5VB20 3.5A 200V
D121	VG441000	DIODE.ZENR	MTZJ16A 16V
D122	VG441000	DIODE.ZENR	MTZJ16A 16V
D123	VD631600	DIODE	1SS133,176,HSS104

* New Parts

MAIN P.C.B.

Schm Ref.	PART NO.	Description
D124	VG440300	DIODE.ZENR MTZJ12C 12V(R)
D125	VU264100	DIODE 1SR139-400
D126	VN008700	DIODE 1SS270A
D127	VG436700	DIODE.ZENR MTZJ4.3A 4.3V
△ F101	KB000760	FUSE T3.15A 250V(G)
△ F101	VS823300	FUSE T8.0A 125V(R)
△ F102	KB002980	FUSE T2.5A 250V(G)
△ F103	KB000760	FUSE T3.15A 250V(R)
△ FR101	VK188200	R.FUS 220É ∂ 1/4W
△ FR102	VK188200	R.FUS 220É ∂ 1/4W
JK102	VJ726800	JACK.MNI
△ JK103	VV118800	OUTLET.AC 3P(R)
△ * JK103	VV119000	OUTLET.AC 3P(G)
L101	VR906600	COIL 0.95uH
L102	VR906600	COIL 0.95uH
Q101	VK432900	TR 2SD1915F S,T
Q102	VK432900	TR 2SD1915F S,T
Q103	iA097000	TR 2SA970 GR,BL
Q104	iA097000	TR 2SA970 GR,BL
Q105	iA097000	TR 2SA970 GR,BL
Q106	iA097000	TR 2SA970 GR,BL
Q107	iC1815C0	TR 2SC1815 Y
Q108	iC1815C0	TR 2SC1815 Y
Q109	iC1815C0	TR 2SC1815 Y
Q110	iC1815C0	TR 2SC1815 Y
△ Q111	VE198700	TR 2SA1145 O,Y
△ Q112	VE198700	TR 2SA1145 O,Y
△ Q113	iA101521	TR 2SA1015 Y
△ Q114	iA101521	TR 2SA1015 Y
△ Q115	VE198800	TR 2SC2705 O,Y
△ Q116	VE198800	TR 2SC2705 O,Y
△ Q117	VK432900	TR 2SD1915F S,T
△ Q118	VK432900	TR 2SD1915F S,T
△ Q119A	iX603580	TR 2SA1358
△ Q119C	iX603590	TR 2SC3421
△ Q120A	iX603580	TR 2SA1358
△ Q120C	iX603590	TR 2SC3421
△ # Q121A	iX630850	TR 2SA1695 O,P,Y
△ # Q121C	iX630860	TR 2SC4468 O,P,Y
△ # Q122A	iX630850	TR 2SA1695 O,P,Y
△ # Q122C	iX630860	TR 2SC4468 O,P,Y
△ # Q123A	iX630850	TR 2SA1695 O,P,Y
△ # Q123C	iX630860	TR 2SC4468 O,P,Y
△ # Q124A	iX630850	TR 2SA1695 O,P,Y
△ # Q124C	iX630860	TR 2SC4468 O,P,Y
△ Q125	VP883000	TR 2SA893A D,E
△ Q126	VP883000	TR 2SA893A D,E
Q127	VP883100	TR 2SC1890A D,E
Q128	VP883100	TR 2SC1890A D,E
Q129	VP883000	TR 2SA893A D,E
△ Q130	VP872700	TR 2SC4488 S,T
△ Q131	VP872600	TR 2SA1708 S,T
Q132	VK432900	TR 2SD1915F S,T

* New Parts

Schm Ref.	PART NO.	Description
Q133	VK432900	TR 2SD1915F S,T
Q134	VP883100	TR 2SC1890A D,E
Q135	VF325300	TR.DGT DTA123ESTP
Q136	VF325300	TR.DGT DTA123ESTP
Q137	VF325300	TR.DGT DTA123ESTP
Q138	VF331200	TR.DGT DTC124ES
Q139	VP872600	TR 2SA1708 S,T
Q140	VP768300	TR 2SC4466 O,P,Y(R)
Q141	iC1815C0	TR 2SC1815 Y(R)
△ R111	VY689500	R.WW 0.22Ω 3W
△ R112	VY689500	R.WW 0.22Ω 3W
△ R125	HL315100	R.MTL.OXD 100Ω 1W
△ R126	HL315100	R.MTL.OXD 100Ω 1W
△ R127	HL315100	R.MTL.OXD 100Ω 1W
△ R128	HL315100	R.MTL.OXD 100Ω 1W
△ R129	HV456270	R.CAR.FP 2.7KΩ 1/4W
△ R130	HV456270	R.CAR.FP 2.7KΩ 1/4W
△ R131	HV455820	R.CAR.FP 820Ω 1/4W
△ R132	HV455820	R.CAR.FP 820Ω 1/4W
R133	HV455270	R.CAR.FP 270Ω 1/4W
R134	HV455270	R.CAR.FP 270Ω 1/4W
△ R135	VY689500	R.WW 0.22Ω 3W
△ R136	VY689500	R.WW 0.22Ω 3W
△ R143	HL314100	R.MTL.OXD 10Ω 1W
△ R144	HL314100	R.MTL.OXD 10Ω 1W
R145	HV453470	R.CAR.FP 4.7Ω 1/4W
R146	HV453470	R.CAR.FP 4.7Ω 1/4W
△ R151	HL314470	R.MTL.OXD 47Ω 1W
△ R152	HL314470	R.MTL.OXD 47Ω 1W
△ R154	HL315680	R.MTL.OXD 680Ω 1W
△ R167	HL315680	R.MTL.OXD 680Ω 1W
△ R168	HL315680	R.MTL.OXD 680Ω 1W
△ R171	HV453100	R.CAR.FP 1Ω 1/4W
△ R172	HV453100	R.CAR.FP 1Ω 1/4W
R175	HV455680	R.CAR.FP 680Ω 1/4W
R176	HV455680	R.CAR.FP 680Ω 1/4W
△ R177	HL315680	R.MTL.OXD 680Ω 1W
△ R178	HL315680	R.MTL.OXD 680Ω 1W
R181	HL314100	R.MTL.OXD 10Ω 1W
R187	VP939700	R.MTL.FLM 4.7Ω 1W
R188	VP939700	R.MTL.FLM 4.7Ω 1W
R189	VP939700	R.MTL.FLM 4.7Ω 1W
R190	VP939700	R.MTL.FLM 4.7Ω 1W
R191	VP939700	R.MTL.FLM 4.7Ω 1W
R192	VP939700	R.MTL.FLM 4.7Ω 1W
R193	VP939700	R.MTL.FLM 4.7Ω 1W
R194	VP939700	R.MTL.FLM 4.7Ω 1W
△ R197	HL315560	R.MTL.OXD 560Ω 1W
△ R198	HL315560	R.MTL.OXD 560Ω 1W
R207	VP939700	R.MTL.FLM 4.7Ω 1W(G)
R208	VP939700	R.MTL.FLM 4.7Ω 1W(G)
R209	VY689500	R.WW 0.22Ω 3W
△ R210	VY689500	R.WW 0.22Ω 3W

* New Parts

MAIN P.C.B. & FUNCTION P. C. B.

Schm Ref.	PART NO.	Description	
△	R213	VY689500	R.WW 0.22Ω 3W
△	R214	VY689500	R.WW 0.22Ω 3W
△	RY101	VY868200	RELAY DC DH24D2-OT(M)-S
△	RY102	VK438300	RELAY DH24D2-OT/M2
△	RY103	VU566700	RELAY DG24D2-OS/M
△	RY104	VU398500	RELAY DC LK1AF-12V(G)
△	RY104	VY735300	RELAY DC G5P-1(R)
△	SW101	VV523800	SW.SLIDE SL13B-022-BMC1
△	SW102	VA961800	VOLT.SELCT ESE-37247-F(R)
△	T101	XC082A00	TRANS.PWR (R)
△	T101	XQ486B00	TRANS.PWR (G)
*	TE102	VV247600	TERM.SP 2P
*	TE103	VV247600	TERM.SP 2P
*	TE104	VV247600	TERM.SP 2P
*	TE105	VV247600	TERM.SP 2P
		BB071360	SCR.TERM 8.3x13
		BB070700	GND.MTL
*		VY672600	PLATE.GND SP(G)
*	VY651405	P.C.B.	FUNCTION(RG)
	CB301	Vi878900	CN.BS.PIN 11P
	CB302	VK025500	CN.BS.PIN 11P
	CB303	Vi878600	CN.BS.PIN 8P
	CB304	VK025200	CN.BS.PIN 8P
	CB305	Vi878500	CN.BS.PIN 7P
	CB306	Vi878500	CN.BS.PIN 7P
	CB307	Vi878500	CN.BS.PIN 7P
	CB308	VK025100	CN.BS.PIN 7P
	CB309	VK026600	CN.BS.PIN 7P
	CB310	VB858700	CN.BS.PIN 8P
	CB311	VD004700	CN.BS.PIN 4P
	CB312	LB919070	CN.BS.PIN 7P
	CB314	VB858200	CN.BS.PIN 3P
	CB315	VB858100	CN.BS.PIN 2P
	CB316	Vi878100	CN.BS.PIN 3P
	CB317	Vi878100	CN.BS.PIN 3P
	CB318	VD004500	CN.BS.PIN 2P
	C303	Vi716700	C.MYLAR 0.01uF 50V
	C304	Vi716700	C.MYLAR 0.01uF 50V
	C305	VG290300	C.EL 0.47uF 50V
	C306	VG290300	C.EL 0.47uF 50V
	C307	VQ462600	C.MYLAR 220pF 50V
	C308	VQ462600	C.MYLAR 220pF 50V
	C309	UA652100	C.MYLAR 100pF 50V
	C310	UA652100	C.MYLAR 100pF 50V
	C311	UA653330	C.MYLAR 3300pF 50V
	C312	UA653330	C.MYLAR 3300pF 50V
	C313	Vi460900	C.EL 2200uF 6.3V
	C314	Vi460900	C.EL 2200uF 6.3V
	C315	UA654330	C.MYLAR 0.033uF 50V
	C316	UA654330	C.MYLAR 0.033uF 50V

* New Parts

Schm Ref.	PART NO.	Description	
	C317	UA653910	C.MYLAR 9100pF 50V
	C318	UA653910	C.MYLAR 9100pF 50V
	C319	VG290900	C.EL 10uF 50V
	C320	VG290900	C.EL 10uF 50V
	C321	Vi715900	C.MYLAR 2200pF 50V
	C322	Vi715900	C.MYLAR 2200pF 50V
	C323	VG287800	C.EL 330uF 16V
	C324	VG287800	C.EL 330uF 16V
	C325	VG291000	C.EL 22uF 50V
	C326	UA655100	C.MYLAR 0.1uF 50V
	C327	VK533900	C.PP 100pF 200V
	C328	VK533900	C.PP 100pF 200V
	C329	VQ645600	C.MYLAR 100pF 50V
	C330	VQ645600	C.MYLAR 100pF 50V
	C331	VQ645600	C.MYLAR 100pF 50V
	C332	VQ645600	C.MYLAR 100pF 50V
	C333	Vi715100	C.MYLAR 470pF 50V
	C334	Vi715100	C.MYLAR 470pF 50V
	C335	VG278400	C.CE.TUBLR 220pF 50V
	C336	VG278400	C.CE.TUBLR 220pF 50V
	C337	VG278400	C.CE.TUBLR 220pF 50V
	C338	VG278400	C.CE.TUBLR 220pF 50V
	C339	VQ645600	C.MYLAR 100pF 50V
	C340	VQ645600	C.MYLAR 100pF 50V
	C341	VF466800	C.CE.TUBLR 100pF 50V
	C342	VF466800	C.CE.TUBLR 100pF 50V
	C343	VG722100	C.EL 1uF 50V
	C344	UA655100	C.MYLAR 0.1uF 50V
	C345	VK533800	C.PP 47pF 200V
	C346	VK533800	C.PP 47pF 200V
	C347	VF466800	C.CE.TUBLR 100pF 50V
	C348	VF466800	C.CE.TUBLR 100pF 50V
	C349	FU451470	C.MICA 47pF 500V
	C350	FU451470	C.MICA 47pF 500V
	C351	VF466800	C.CE.TUBLR 100pF 50V
	C352	VF466800	C.CE.TUBLR 100pF 50V
	C353	UA655100	C.MYLAR 0.1uF 50V
	C354	Vi716700	C.MYLAR 0.01uF 50V
	C355	VK533800	C.PP 47pF 200V
	C356	VK533800	C.PP 47pF 200V
	C357	Vi377400	C.EL 4.7uF 63V
	C358	Vi377400	C.EL 4.7uF 63V
	C359	VG287100	C.EL 470uF 10V
	C360	VG287100	C.EL 470uF 10V
	C361	Vi377400	C.EL 4.7uF 63V
	C362	Vi377400	C.EL 4.7uF 63V
	C363	UA653220	C.MYLAR 2200pF 50V
	C364	UA653220	C.MYLAR 2200pF 50V
	C365	VG288000	C.EL 1000uF 16V
	C366	VG288000	C.EL 1000uF 16V
	C367	UA653220	C.MYLAR 2200pF 50V
	C368	UA653220	C.MYLAR 2200pF 50V
	C369	VG290900	C.EL 10uF 50V

* New Parts

FUNCTION P.C.B.

Schm Ref.	PART NO.	Description		
C370	VG290900	C.EL	10uF	50V
C371	VG286400	C.EL	330uF	6.3V
C372	VG286400	C.EL	330uF	6.3V
C373	VG288900	C.EL	100uF	25V
C374	VG288900	C.EL	100uF	25V
C375	UA654560	C.MYLAR	0.056uF	50V
C376	UA654560	C.MYLAR	0.056uF	50V
C377	VG278900	C.CE.TUBLR	680pF	50V
C378	VG278900	C.CE.TUBLR	680pF	50V
C379	UA654470	C.MYLAR	0.047uF	50V
C380	UA654470	C.MYLAR	0.047uF	50V
C381	UA654680	C.MYLAR	0.068uF	50V
C382	UA654680	C.MYLAR	0.068uF	50V
C383	UA654680	C.MYLAR	0.068uF	50V
C384	UA654680	C.MYLAR	0.068uF	50V
C385	VG290300	C.EL	0.47uF	50V
C386	VG290300	C.EL	0.47uF	50V
C387	VG278400	C.CE.TUBLR	220pF	50V
C388	VG278400	C.CE.TUBLR	220pF	50V
C389	Vi377400	C.EL	4.7uF	63V
C390	Vi377400	C.EL	4.7uF	63V
C391	VF466700	C.CE.TUBLR	47pF	50V
C392	VF466700	C.CE.TUBLR	47pF	50V
C393	VG291200	C.EL	47uF	50V
C394	VG291200	C.EL	47uF	50V
C395	UA655120	C.MYLAR	0.12uF	50V
C396	UA655120	C.MYLAR	0.12uF	50V
C399	UA654330	C.MYLAR	0.033uF	50V
C400	UA654330	C.MYLAR	0.033uF	50V
C401	VG288900	C.EL	100uF	25V
C402	VG288900	C.EL	100uF	25V
C403	UA654100	C.MYLAR	0.01uF	50V
C404	UA654100	C.MYLAR	0.01uF	50V
C405	VF760000	C.EL	100uF	10V
C406	VF760000	C.EL	100uF	10V
C407	VG290900	C.EL	10uF	50V
C408	VG290900	C.EL	10uF	50V
C409	VG287100	C.EL	470uF	10V
C410	VG291200	C.EL	47uF	50V
C411	VT180400	C.EL	4700uF	5.5V
C412	VH053100	C.CE.TUBLR	0.1uF	50V
C413	VG290900	C.EL	10uF	50V
C414	VG290500	C.EL	1uF	50V
C415	VH053100	C.CE.TUBLR	0.1uF	50V
C416	VG289100	C.EL	330uF	25V
C417	VH053100	C.CE.TUBLR	0.1uF	50V
C418	VG291200	C.EL	47uF	50V
C420	UM049220	C.EL	2200uF	16V
C421	UM049220	C.EL	2200uF	16V
* C423	VQ083100	C.EL	100uF	16V
* C424	VQ083100	C.EL	100uF	16V
C425	VE021900	C.EL	4.7uF	100V
C426	VE021900	C.EL	4.7uF	100V

* New Parts

Schm Ref.	PART NO.	Description		
C427	UA654330	C.MYLAR	0.033uF	50V
C430	Vi377400	C.EL	4.7uF	63V
C431	UA655120	C.MYLAR	0.12uF	50V
C432	UA655120	C.MYLAR	0.12uF	50V
C433	UA655100	C.MYLAR	0.1uF	50V
C434	VH053100	C.CE.TUBLR	0.1uF	50V
C435	VF467100	C.CE.TUBLR	4700pF	16V
C436	VF467100	C.CE.TUBLR	4700pF	16V
D301	VD631600	DIODE	1SS133,176,HSS104	
D302	VD631600	DIODE	1SS133,176,HSS104	
D303	VG437800	DIODE.ZENR	MTZJ5.6C	5.6V
D304	VG435800	DIODE.ZENR	MTZJ3.0A	3.0V
D305	VG437000	DIODE.ZENR	MTZJ4.7A	4.7V
D306	VD631600	DIODE	1SS133,176,HSS104	
D307	VD631600	DIODE	1SS133,176,HSS104	
D308	VD631600	DIODE	1SS133,176,HSS104	
D309	VD631600	DIODE	1SS133,176,HSS104	
D310	VG438100	DIODE.ZENR	MTZJ6.2C	6.2V
D311	VD631600	DIODE	1SS133,176,HSS104	
D312	VD631600	DIODE	1SS133,176,HSS104	
D313	VG437800	DIODE.ZENR	MTZJ5.6C	5.6V
D314	VD631600	DIODE	1SS133,176,HSS104	
D315	VD631600	DIODE	1SS133,176,HSS104	
D316	VR711500	LED(or)	SLR-325DC	
D317	VR711500	LED(or)	SLR-325DC	
D318	VR711500	LED(or)	SLR-325DC	
D319	VD631600	DIODE	1SS133,176,HSS104	
D320	VD631600	DIODE	1SS133,176,HSS104	
D321	VD631600	DIODE	1SS133,176,HSS104	
D322	VS132300	LED(re)	SLR-325VCT31	
IC301	XB247301	IC	uPC4570HA	
IC302	XQ212A00	IC	NJM4558LD	
IC305	XM356A00	IC	NJM2068LD	
IC306	XM356A00	IC	NJM2068LD	
IC307	XF557A00	IC	TA7291S	
IC308	XF557A00	IC	TA7291S	
* IC309	XS966A00	IC	LC6520H-4J33 CPU	
JK301	VS899700	JACK.PHONE	JY-6317-02-030	
L301	VF541100	COIL	15uH	
L302	VF541100	COIL	15uH	
L303	VB056900	COIL	220uH	
L304	VB056900	COIL	220uH	
L305	Vi543300	COIL	1.0uH	
* PJ301	VV248000	JACK.PIN	2P	
* PJ302	VV248000	JACK.PIN	2P	
* PJ303	VV551500	JACK.PIN	4P	
* PJ304	VV551500	JACK.PIN	4P	
* PJ305	VV551500	JACK.PIN	4P	
* PJ306	VV551500	JACK.PIN	4P	
Q301	iA097000	TR	2SA970 GR,BL	
Q302	iA097000	TR	2SA970 GR,BL	
Q303	iA097000	TR	2SA970 GR,BL	
Q304	iA097000	TR	2SA970 GR,BL	

* New Parts

FUNCTION P.C.B.

Schm Ref.	PART NO.	Description	
Q305	VK432900	TR	2SD1915F S,T
Q306	VK432900	TR	2SD1915F S,T
Q307	VK432900	TR	2SD1915F S,T
Q308	VK432900	TR	2SD1915F S,T
Q309	VG721700	TR.DGT	DTA144ES
Q310	VD678700	TR.DGT	DTC114ES
Q311	VD678700	TR.DGT	DTC114ES
Q312	VD678700	TR.DGT	DTC114ES
Q313	iC174020	TR	2SC1740S R,S
Q314	VG721700	TR.DGT	DTA144ES
Q315	iA093320	TR	2SA933S Q,R
Q316	VP883100	TR	2SC1890A D,E
Q317	VG721700	TR.DGT	DTA144ES
Q318	iC174020	TR	2SC1740S R,S
Q319	VG722000	TR.DGT	DTC144ES
Q320	iA093320	TR	2SA933S Q,R
Q321	VP883100	TR	2SC1890A D,E
Q322	iC224030	TR	2SC2240 GR,BL
Q323	iC174020	TR	2SC1740S R,S
Q324	iC174020	TR	2SC1740S R,S
Q325	iA093320	TR	2SA933S Q,R
Q326	iA093320	TR	2SA933S Q,R
Q327	iA093320	TR	2SA933S Q,R
Q328	iA093320	TR	2SA933S Q,R
Q329	iC174020	TR	2SC1740S R,S
Q330	iC174020	TR	2SC1740S R,S
Q331	VK432900	TR	2SD1915F S,T
Q332	VK432900	TR	2SD1915F S,T
Q333	iC174020	TR	2SC1740S R,S
Q334	iC174020	TR	2SC1740S R,S
Q335	iA093320	TR	2SA933S Q,R
Q336	iA093320	TR	2SA933S Q,R
Q337	VP883100	TR	2SC1890A D,E
R358	HL315100	R.MTL.OXD	100Ω 1W
R359	HL315100	R.MTL.OXD	100Ω 1W
R478	HV453470	R.CAR.FP	4.7Ω 1/4W
SW301	VK333500	SW.PUSH	SPUN19
SW302	VS892300	SW.RT	SRBAA46
SW303	VT021200	SW.RT	RS003-A046BHN-20F4
* SW304	VV399900	SW.PUSH	SPUN12
* SW305	VV399800	SW.PUSH	SPUN12
SW306	VJ850300	SW.PUSH	PSEOYP-CF2KX
* SW307	VV496300	SW.PUSH	PS-9A2-022-18A-A
SW308	VV523900	SW.PUSH	PBS-YM-001
* SW309	VV496300	SW.PUSH	PS-9A2-022-18A-A
U301	VU591000	L.DTCT	GP1U271X
* VR301	VV856800	VR.MTR	A200KΩ
VR302	VP700700	VR	A100KΩ
VR303	VP742000	VR	MN100KΩ
VR304	VP741800	VR	B20KΩ
VR305	VP741900	VR	G25KΩ
XL301	VE906000	RSNR.CE	4MHz
	VJ828000	PIN	IMSA-6024-03E

* New Parts

Schm Ref.	PART NO.	Description	
	BB071360	SCR.TERM	8.3x13
	AA626100	PLATE	25

* New Parts

A

B

C

D

AX-592/AX-892

AX-592

AX-592 EXPLODED VIEW

1

2

3

4

5

6

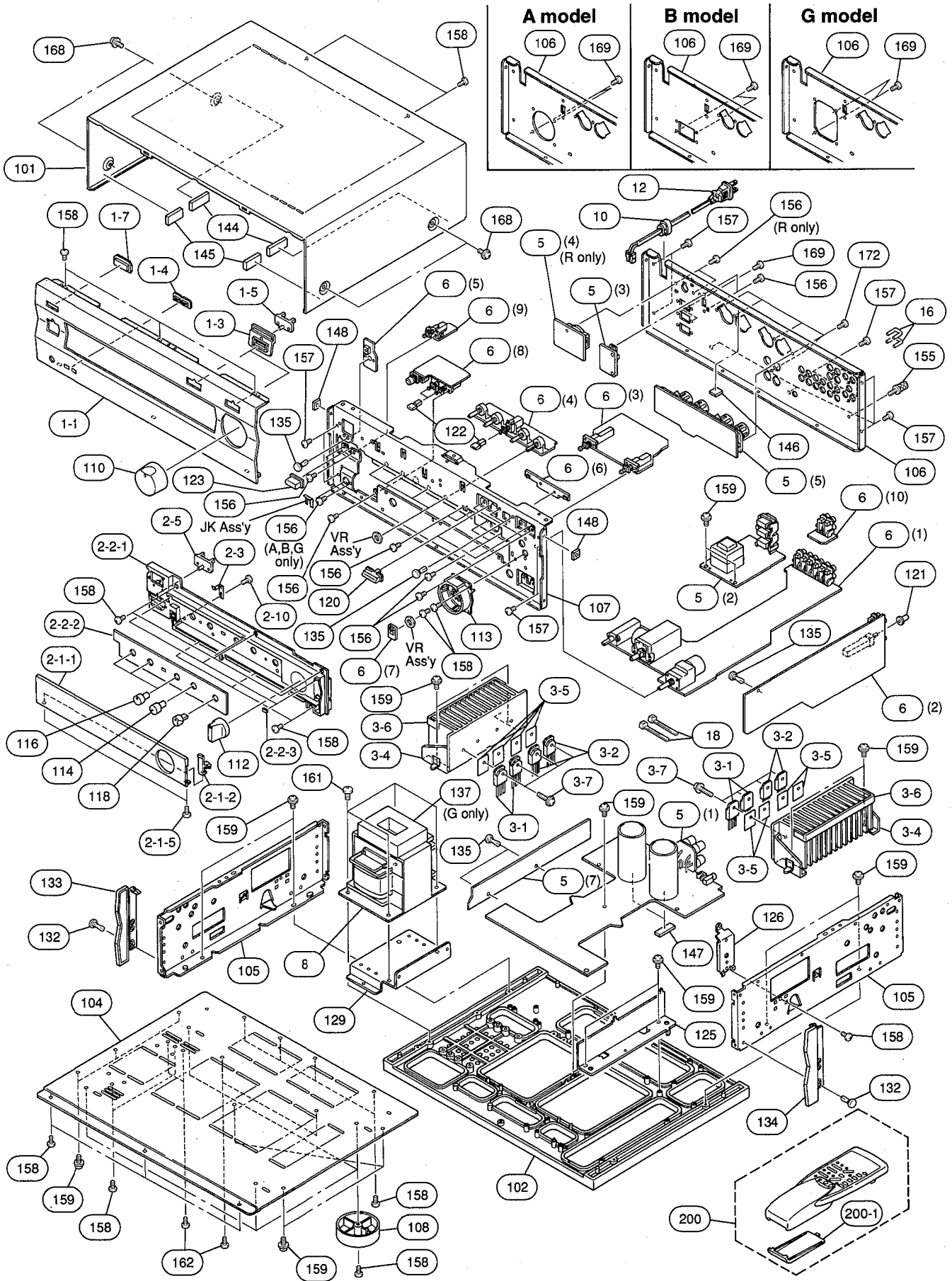

■ AX-592 MECHANICAL PARTS

Ref. No.	PART NO.	Description	Remarks	Markets
* 1-1	VV187000	FRONT PANEL		BL
* 1-1	VV187100	FRONT PANEL		TI
* 1-3	VV185400	ESCUTCHEON	8x26	BL
* 1-3	VV185500	ESCUTCHEON	8x26	TI
1-4	VV123700	ESCUTCHEON, 3/8	2P	BL
1-4	VV123800	ESCUTCHEON, 3/8	2P	TI
* 1-5	VV185600	LENS, LED	D2	
* 1-7	VV185700	LENS, FILTER	7x24	
* 2-1-1	VV187200	PANEL, LID		BL
* 2-1-1	VV187300	PANEL, LID		TI
2-1-2	VS585900	HINGE, LID		BL
2-1-2	VS586000	HINGE, LID		TI
* 2-2-1	VV184500	SUB PANEL		BL
* 2-2-1	VV184600	SUB PANEL		TI
* 2-2-2	VV185800	PLATE, LID		BL
* 2-2-2	VV185900	PLATE, LID		TI
2-2-3	VY940400	CUSHION, LID	T=0.8	
2-1-5	EX601590	BIND HEAD P-TITE SCREW	2.6x8 FCRM3-BL	
2-3	VS586100	SPRING	HINGE	
* 2-5	VV185600	LENS, LED	D2	
2-10	EX600310	BIND HEAD P-TITE SCREW	3x8 FCRM3-BL	
△ # 3-1	iX615750	TRANSISTOR	2SA1694 O,P,Y	Q121A-124A
△ # 3-2	iX615760	TRANSISTOR	2SC4467 O,P,Y	Q121C-124C
3-4	VY732600	HEAT SINK ASS'Y		
3-5	VV849300	RADIATION SHEET	BFG-20ADH-3 19X24	
3-6	VP922500	DAMPER	2x10x170	
3-7	VK173200	SCREW, TRANSISTOR	3x15 SP FCM3	
* 5	VY648300	P.C.B. ASS'Y	MAIN	(UC)
* 5	VY648400	P.C.B. ASS'Y	MAIN	(R)
* 5	VY648500	P.C.B. ASS'Y	MAIN	(A)
* 5	VY648600	P.C.B. ASS'Y	MAIN	(B)
* 5	VY648700	P.C.B. ASS'Y	MAIN	(G)
* 6	VY648000	P.C.B. ASS'Y	FUNCTION	(JUC)
* 6	VY648100	P.C.B. ASS'Y	FUNCTION	(RABG)
△ * 8	XT052A00	POWER TRANSFORMER		(U)
△ * 8	XT053A00	POWER TRANSFORMER		(C)
△ * 8	XT055A00	POWER TRANSFORMER		(A)
△ * 8	XT056A00	POWER TRANSFORMER		(BG)
△ 8	XT060A00	POWER TRANSFORMER		(R)
10	VN158600	CORD STOPPER	No.2104	
△ 12	VL238100	POWER CORD ASS'Y		(R)
△ 12	VN363700	POWER CORD ASS'Y		(G)
△ 12	VQ508600	POWER CORD ASS'Y		(A)
△ 12	VV437200	POWER CORD ASS'Y		(UC)
△ 12	VV437300	POWER CORD ASS'Y		(B)
16	VQ194100	SHORT PLUG	CNT31-0	
18	VU590000	BINDING TIE	CBTD001B	
101	VV121300	TOP COVER		BL
101	VV121500	TOP COVER		TI
102	VN946400	CHASSIS		
* 104	VV184400	BOTTOM COVER		
105	VL664800	"FRAME, SIDE"		
* 106	VV186200	REAR PANEL		(U)

* New Parts

AX-592

Ref. No.	PART NO.	Description	Remarks	Markets
* 106	VV186300	REAR PANEL		(C)
* 106	VV186400	REAR PANEL		(R)
* 106	VV186500	REAR PANEL		(A)
* 106	VV186600	REAR PANEL		(B)
* 106	VV186700	REAR PANEL		(G)
* 107	VV186000	SUB CHASSIS		
108	VS025000	LEG	D60xH21	
* 110	VV268600	KNOB, LED	D40	BL
* 110	VV268700	KNOB, LED	D40	TI
* 112	VV184700	KNOB, LED	D28	BL
* 112	VV184800	KNOB, LED	D28	TI
113	VV149500	ESCUTCHEON, VOL		BL
113	VV149600	ESCUTCHEON, VOL		TI
114	VS757400	KNOB, PL	D12	BL
114	VS757500	KNOB, PL	D12	TI
116	VS757200	KNOB, P	D12	BL
116	VS757300	KNOB, P	D12	TI
118	VT275100	KNOB	D12R	BL
118	VT275200	KNOB	D12R	TI
* 120	VV185200	BUTTON	8x26	BL
* 120	VV185300	BUTTON	8x26	TI
121	VS048300	BUTTON	D7	BL
122	VV123500	BUTTON, 3/8		BL
122	VV123600	BUTTON, 3/8		TI
* 123	VU875100	BUTTON	9.5x22	BL
* 123	VU875200	BUTTON	9.5x22	TI
* 125	VV186900	SUPPORT PCB		
126	VY805200	SUPPORT, F		
129	VY732900	FRAME, TR592		
132	VQ368600	PUSH RIVET	P3555-B	
133	VV124300	PLATE SIDE L	130	BL
133	VV124400	PLATE SIDE L	130	TI
134	VV124500	PLATE SIDE R	130	BL
134	VV124600	PLATE SIDE R	130	TI
135	VQ368500	PUSH RIVET	P3545-B	
137	VY900000	DAMPER, T21	TRANS	(G)
144	VZ117100	DAMPER, T2	TOP-F	
145	VZ117200	DAMPER, T3	TOP-F	
146	VZ117300	DAMPER, T5	PCB	
147	VZ203600	DAMPER, T16	PCB	
148	VY989400	DAMPER	SIDE	
155	AA627310	GROUND TERMINAL		
156	ED330066	BIND HEAD SCREW	3x6 FCRM3-BL	
157	EN301010	BIND HEAD BONDING TAP. SCREW	3x8 FCRM3-BL	
158	Ei330086	BIND HEAD B-TITE SCREW	3x8 FCRM3-BL	
159	VB770200	PW HEAD P-TITE SCREW	3x10-8 FCM3	
161	EN330060	BIND HEAD B-TITE SCREW	4x16 FCRM3-BL	
162	VL184400	BIND HEAD B-TITE SCREW	4x22 FCRM3-BL	
168	EK365090	PW HEAD S-TITE SCREW	4x8-10 FCRM3-BL	BL
168	EX601150	BW HEAD S-TITE SCREW	4x8-10 FNM3-BL	TI
169	Ei030086	BIND HEAD B-TITE SCREW	3x8 ZMC2-Y	
172	VY731200	BONDING HEAD TAPPING SCREW	3x10 MFNI33	

* New Parts

Ref. No.	PART NO.	Description	Remarks	Markets
200 200-1	VY755700 CX679050	ACCESSORIES REMOTE CONTROL TRANSMITTER LID BATTERY, MANGANESE	SBGH20021A RAX5 74x34BLALPS SUM-3,AA,R06	

* New Parts

A

B

C

D

AX-592/AX-892

AX-892

AX-892 EXPLODED VIEW

1

2

3

4

5

6

G model

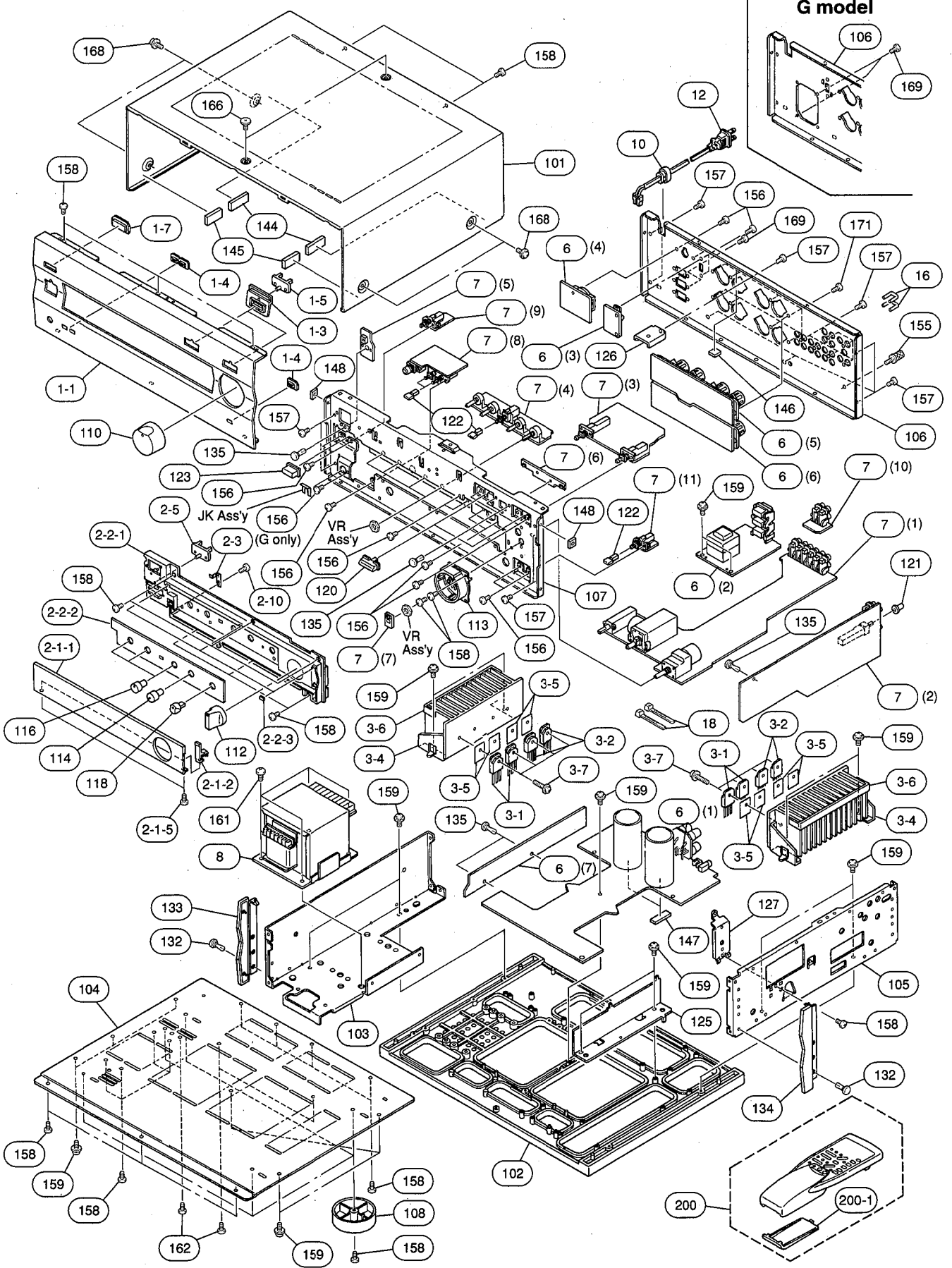

■ AX-892 MECHANICAL PARTS

Ref. No.	PART NO.	Description	Remarks	Markets
* 1-1	VV189600	FRONT PANEL	BL	
* 1-1	VV189700	FRONT PANEL	TI	
* 1-3	VV185400	ESCUTCHEON	8x26 BL	
* 1-3	VV185500	ESCUTCHEON	8x26 TI	
1-4	VV123700	ESCUTCHEON, 3/8	2P BL	
1-4	VV123800	ESCUTCHEON, 3/8	2P TI	
* 1-5	VV185600	LENS, LED	D2	
* 1-7	VV185700	LENS, FILTER	7x24	
2-1-1	VV187200	PANEL, LID	BL	
2-1-1	VV187300	PANEL, LID	TI	
2-1-2	VS585900	HINGE, LID	BL	
2-1-2	VS586000	HINGE, LID	TI	
2-1-5	EX601590	BIND HEAD P-TITE SCREW	2.6x8 FCRM3-BL	
2-2-1	VV184500	SUB PANEL	BL	
2-2-1	VV184600	SUB PANEL	TI	
2-2-2	VV185800	PLATE, LID	SUB PANEL BL	
2-2-2	VV185900	PLATE, LID	TI	
2-2-3	VY940400	CUSHION, LID	T=0.8	
2-3	VS586100	SPRING	HINGE	
* 2-5	VV185600	LENS, LED	D2	
2-10	EX600310	BIND HEAD P-TITE SCREW	3x8 FCRM3-BL	
△ # 3-1	iX630850	TRANSISTOR	2SA1695 O,P,Y	Q121A-124A
△ # 3-2	iX630860	TRANSISTOR	2SC4468 O,P,Y	Q121C-124C
* 3-4	VV491700	HEAT SINK ASS'Y	H65	
3-5	VV849300	RADIATION SHEET	BFG-20ADH-3 19X24	
3-6	VP922500	DAMPER	2x10x170	
3-7	VK173200	SCREW, TRANSISTOR	3x15 SP FCM3	
* 6	VY651600	P.C.B. ASS'Y	MAIN	(R)
* 6	VY651700	P.C.B. ASS'Y	MAIN	(G)
* 7	VY651400	P.C.B. ASS'Y	FUNCTION	(RG)
△ * 8	XT046A00	POWER TRANSFORMER		(R)
△ * 8	XT047A00	POWER TRANSFORMER		(G)
10	VN158600	CORD STOPPER	No.2104	(G)
△ 12	VL238100	POWER CORD ASS'Y		(R)
△ 12	VN363700	POWER CORD ASS'Y		(G)
16	VQ194100	SHORT PLUG	CNT31-0	
18	VU590000	BINDING TIE	CBTD001B	
* 101	VV263800	TOP COVER	BL	
* 101	VV263900	TOP COVER	TI	
102	VN946400	CHASSIS		
* 103	VV206000	FRAME	L	
* 104	VV184400	BOTTOM COVER		
105	VL664800	FRAME, SIDE		
* 106	VV189300	REAR PANEL		(R)
* 106	VV189400	REAR PANEL		(G)
* 107	VV189100	SUB CHASSIS		
108	VS025000	LEG	D60xH21	
* 110	VV268600	KNOB, LED	D40	BL
* 110	VV268700	KNOB, LED	D40	TI
112	VV184700	KNOB, LED	D28	BL
* 112	VV184800	KNOB, LED	D28	TI
113	VV149500	ESCUTCHEON, VOL		BL
113	VV149600	ESCUTCHEON, VOL		TI

* New Parts

AX-892

Ref. No.	PART NO.	Description	Remarks	Markets
114	VS757400	KNOB, PL	D12	BL
114	VS757500	KNOB, PL	D12	TI
116	VS757200	KNOB, P	D12	BL
116	VS757300	KNOB, P	D12	TI
118	VT275100	KNOB	D12R	BL
118	VT275200	KNOB	D12R	TI
* 120	VV185200	BUTTON	8x26	BL
* 120	VV185300	BUTTON	8x26	TI
121	VS048300	BUTTON	D7	
122	VV123500	BUTTON, 3/8		BL
122	VV123600	BUTTON, 3/8		TI
* 123	VU875100	BUTTON	9.5x22	BL
* 123	VU875200	BUTTON	9.5x22	TI
* 125	VV299200	FRAME		
* 126	VV306200	SSUPPORT, TOP		
127	VY805200	SUPPORT, F		
132	VQ368600	PUSH RIVET	P3555-B	
* 133	VV263400	PLATE SIDE L	L	BL
* 133	VV263500	PLATE SIDE L	L	TI
* 134	VV263600	PLATE SIDE R	R	BL
* 134	VV263700	PLATE SIDE R	R	TI
135	VQ368500	PUSH RIVET	P3545-B	
144	VZ117100	DAMPER, T2	TOP-F	
145	VZ117200	DAMPER, T3	TOP-F	
146	VZ117300	DAMPER, T5	PCB	
147	VZ203600	DAMPER, T16	PCB	
148	VY989400	DAMPER	SIDE	
155	AA627310	GROUND TERMINAL		
156	ED330066	BIND HEAD SCREW	3x6 FCRM3-BL	
157	EN301010	BIND HEAD BONDING TAP. SCREW	3x8 FCRM3-BL	
158	Ei330086	BIND HEAD B-TITE SCREW	3x8 FCRM3-BL	
159	VB770200	PW HEAD P-TITE SCREW	3x10-8 FCM3	
161	EN330060	BIND HEAD B-TITE SCREW	4x16 FCRM3-BL	
162	VL184400	BIND HEAD B-TITE SCREW	4x22 FCRM3-BL	
166	EX601850	SPECIAL SCREW S-TITE	4x8-10 FCRM3-BL	BL
166	EX601860	SPECIAL SCREW S-TITE	4x8-10 FNM3-BL	TI
168	EK365090	PW HEAD S-TITE SCREW	4x8-10 FCRM3-BL	BL
168	EX601150	BW HEAD S-TITE SCREW	4x8-10 FNM3-BL	TI
169	Ei030086	BIND HEAD B-TITE SCREW	3x8 ZMC2-Y	
171	VY731200	BONDING HEAD TAPPING SCREW	3x10 MFNI33	
200	VU074100	ACCESSORIES REMOTE CONTROL TRANSMITTER		
200-1	CX679050	LID BATTERY, MANGANESE	74x34BLALPS SUM-3,AA,R06	

* New Parts

REMOTE CONTROL TRANSMITTER

SCHEMATIC DIAGRAM

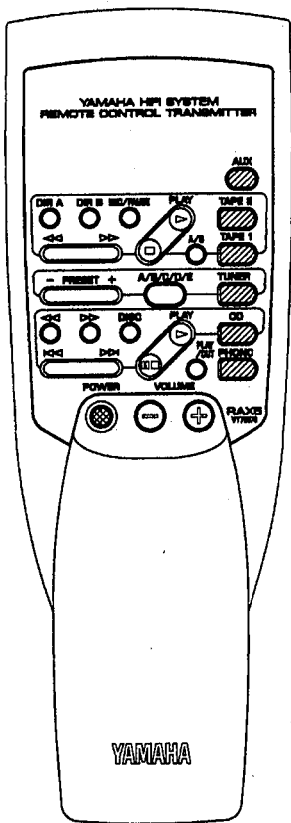
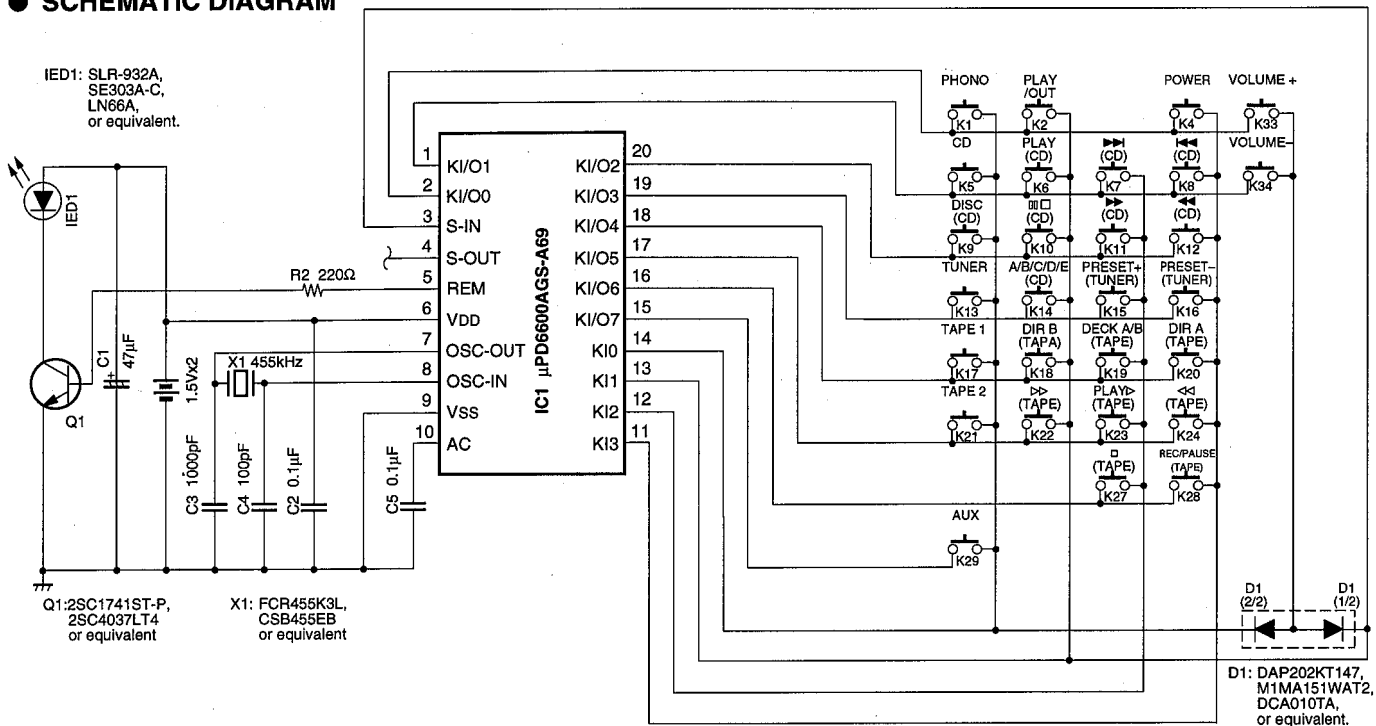

Key No.	Function	HEX	
		CUSTOM	DATA
1	PHONO	7A	14
2	PLAY/CUT	7A	0E
4	POWER	7A	1F
5	CD	7A	15
6	PLAY > (CD)	7A	08
7	SKIP >> (CD)	7A	0A
8	SKIP << (CD)	7A	0B
9	DISC SKIP (CD)	7A	4F
10	PAUSE/STOP (CD)	7A	09
11	SEARCH >> (CD)	7A	0C
12	SEARCH << (CD)	7A	0D
13	TUNER	7A	16
14	A/B/C/D/E (TUNER)	7A	12
15	PRESET + (TUNER)	7A	10
16	PRESET - (TUNER)	7A	11
17	TAPE 1	7A	18
18	DIR B (TAPE)	7A	40
19	DECK A/B (TAPE)	7A	06
20	DIR A (TAPE)	7A	07
21	TAPE 2	7A	19
22	>> (TAPE)	7A	02
23	PLAY > (TAPE)	7A	00
24	<< (TAPE)	7A	01
27	STOP (TAPE)	7A	03
28	REC/PAUSE (TAPE)	7A	04
29	AUX	7A	17
33	VOLUME +	7A	1A
34	VOLUME -	7A	1B

Parts List for Carbon Resistors

Value	1/4W Type Part No.	1/6W Type Part No.	Value	1/4W Type Part No.	1/6W Type Part No.
1.0 Ω	HJ35 3100	HF85 3100	10 kΩ	HF45 7100	HF45 7100
1.8 Ω	HJ35 3180	*	11 kΩ	HF45 7110	HF45 7110
2.2 Ω	HJ35 3220	HF85 3220	12 kΩ	HJ35 7120	HF85 7120
3.3 Ω	HJ35 3330	HF85 3330	13 kΩ	HF45 7130	HF45 7130
4.7 Ω	HJ35 3470	HF85 3470	15 kΩ	HF45 7150	HF45 7150
5.6 Ω	HJ35 3560	HF85 3560	18 kΩ	HF45 7180	HF45 7180
10 Ω	HF45 4100	HF45 4100	22 kΩ	HF45 7220	HF45 7220
15 Ω	HJ35 4150	HF85 4150	24 kΩ	HF45 7240	HF45 7240
22 Ω	HF45 4220	HF45 4220	27 kΩ	HJ35 7270	HF85 7270
27 Ω	HJ35 4270	HF85 4270	30 kΩ	HF45 7300	HF45 7300
33 Ω	HF45 4330	HF45 4330	33 kΩ	HF45 7330	HF45 7330
39 Ω	HJ35 4390	HF85 4390	36 kΩ	HF45 7360	HF45 7360
47 Ω	HF45 4470	HF45 4470	39 kΩ	HF45 7390	HF45 7390
56 Ω	HF45 4560	HF45 4560	47 kΩ	HF45 7470	HF45 7470
68 Ω	HF45 4680	HF45 4680	51 kΩ	HF45 7510	HF45 7510
75 Ω	HF45 4750	HF45 4750	56 kΩ	HF45 7560	HF45 7560
82 Ω	HF45 4820	HF45 4820	62 kΩ	HF45 7620	HF45 7620
91 Ω	HF45 4910	HF45 4910	68 kΩ	HF45 7680	HF45 7680
100 Ω	HF45 5100	HF45 5100	82 kΩ	HF45 7820	HF45 7820
110 Ω	HJ35 5110	HF85 5110	91 kΩ	HF45 7910	HF45 7910
120 Ω	HF45 5120	HF45 5120	100 kΩ	HF45 8100	HF45 8100
150 Ω	HF45 5150	HF45 5150	110 kΩ	HF45 8110	HF45 8110
160 Ω	HJ35 5160	*	120 kΩ	HF45 8120	HF45 8120
180 Ω	HF45 5180	HF45 5180	150 kΩ	HF45 8150	HF45 8150
200 Ω	HF45 5200	HF45 5200	180 kΩ	HF45 8180	HF45 8180
220 Ω	HF45 5220	HF45 5220	220 kΩ	HJ35 8220	HF85 8220
270 Ω	HF45 5270	HF45 5270	270 kΩ	HF45 8270	HF45 8270
330 Ω	HF45 5330	HF45 5330	300 kΩ	HF45 8300	HF45 8300
390 Ω	HF45 5390	HF45 5390	330 kΩ	HF45 8330	HF45 8330
430 Ω	HF45 5430	HF45 5430	390 kΩ	HJ35 8390	HF85 8390
470 Ω	HF45 5470	HF45 5470	470 kΩ	HF45 8470	HF45 8470
510 Ω	HF45 5510	HF45 5510	560 kΩ	HJ35 8560	HF85 8560
560 Ω	HF45 5560	HF45 5560	680 kΩ	HJ35 8680	HF85 8680
680 Ω	HF45 5680	HF45 5680	820 kΩ	HJ35 8820	HF85 8820
820 Ω	HF45 5820	HF45 5820	1.0 MΩ	HF45 9100	HF45 9100
910 Ω	HF45 5910	HF45 5910	1.2 MΩ	HJ35 9120	*
1.0 kΩ	HF45 6100	HF45 6100	1.5 MΩ	HJ35 9150	HF85 9150
1.2 kΩ	HF45 6120	HF45 6120	1.8 MΩ	HJ35 9180	HF85 9180
1.5 kΩ	HF45 6150	HF45 6150	2.2 MΩ	HJ35 9220	HF85 9220
1.8 kΩ	HF45 6180	HF45 6180	3.3 MΩ	HJ35 9330	HF85 9330
2.0 kΩ	HJ35 6200	HF85 6200	3.9 MΩ	HJ35 9390	*
2.2 kΩ	HF45 6220	HF45 6220	4.7 MΩ	HJ35 9470	HF85 9470
2.4 kΩ	HJ35 6240	HF85 6240			
2.7 kΩ	HF45 6270	HF45 6270			
3.0 kΩ	HF45 6300	HF45 6300			
3.3 kΩ	HF45 6330	HF45 6330			
3.6 kΩ	HJ35 6360	HF85 6360			
3.9 kΩ	HF45 6390	HF45 6390			
4.7 kΩ	HF45 6470	HF45 6470			
5.1 kΩ	HF45 6510	HF45 6510			
5.6 kΩ	HF45 6560	HF45 6560			
6.8 kΩ	HF45 6680	HF45 6680			
8.2 kΩ	HF45 6820	HF45 6820			
9.1 kΩ	HF45 6910	HF45 6910			

1/4W Type
HJ35 ○○○○

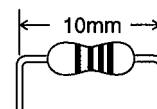

1/4W Type
HF45 ○○○○
1/6W Type
HF85 ○○○○

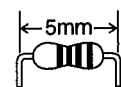

*: Not available